

# 5X30 B Manual

[Monocular installation](#)

[Description](#)

[Legal compliances and disclaimers](#)

# Monocular installation

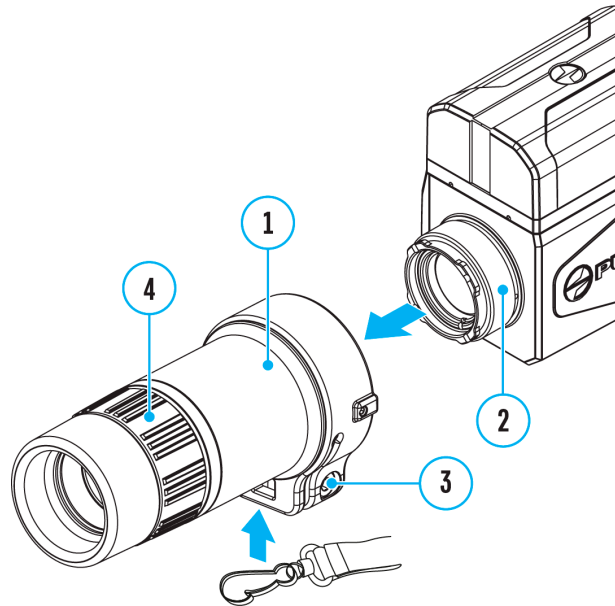

1. Align the protrusions on the monocular **(1)** on the side of its lens with the grooves of the mount **(2)** of the thermal imaging module.
2. Turn the monocular clockwise to secure it on the thermal imaging module. The recommended position of the clamping screw **(3)** is at the bottom (see Figure).
3. Turn on the thermal imaging module.
4. Adjust the eyepiece diopter ring **(4)** until the symbols in the display are sharp.
5. Loosen the screw **(3)** with an Allen key S3.
6. Align the display to the centre of the image in the monocular by tilting the thermal imaging module in the required directions.

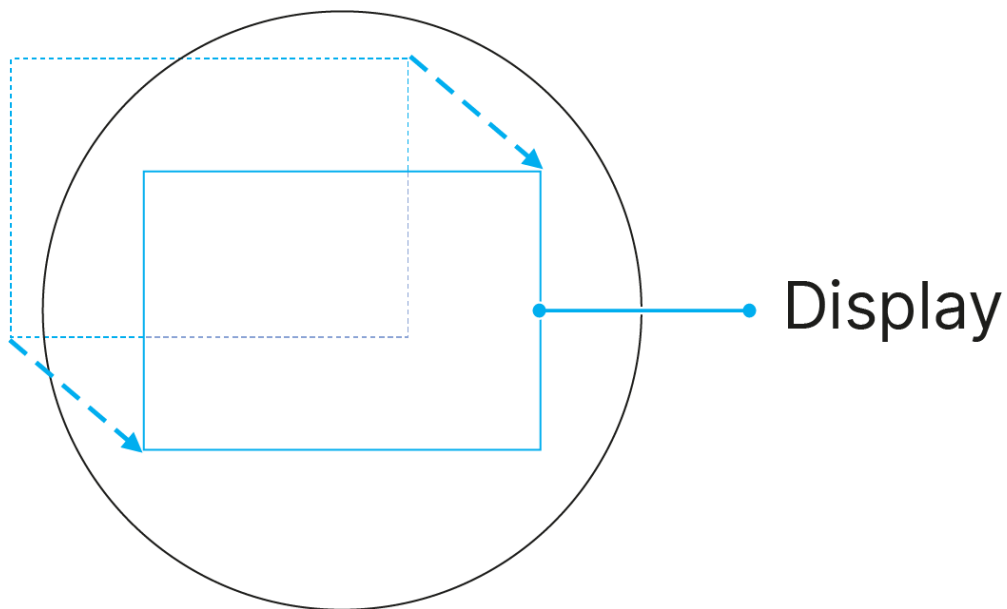

7. Lock the monocular in the chosen position by tightening the screw **(3)** until it stops (clamping force – 2.5 Nm/ 22.13 in-lbs).

8. To remove the monocular, turn it counterclockwise and disconnect from the thermal imaging module.

---

## Description

The **monocular Pulsar 3×20 B** converts Krypton and Proton devices into handheld thermal imaging monoculars with 3x magnification.

The monocular is installed on the thermal imaging module without the use of an additional adapter.

---

## Legal compliances and disclaimers

**Updates of the Product.** The manufacturer reserves the right at any time, without mandatory prior notice to the Customer, to make changes to the package contents (subject to the applicable laws, if any), design and characteristics that do not impair the quality of the Product.

**Limitation of Liability.** Subject to mandatory applicable laws and regulations: manufacturer will not be liable for any claims, actions, suits, proceedings, costs, expenses, damages or liabilities (if any), arising out of the use of this product. Operation and use of the product are the sole responsibility of the Customer. Manufacturer's sole undertaking is limited to providing the product(s) and related services in accordance with the terms and conditions of concluded transactions, including provisions established in warranty. The provision of products sold and services performed by Manufacturer to the Customer shall not be interpreted, construed, or regarded, either expressly or implied, as being for the benefit of or creating any obligation toward any third party (other than Distributor, Dealer, Buyer). Manufacturer's liability hereunder for damages, regardless of the form or action, shall not exceed the fees or other charges paid to Manufacturer for the product(s) and/or service(s).

MANUFACTURER WILL NOT BE LIABLE FOR LOST REVENUES OR INDIRECT, SPECIAL, INCIDENTAL, CONSEQUENTIAL, EXEMPLARY, OR PUNITIVE DAMAGES, EVEN IF THE MANUFACTURER KNEW OR SHOULD HAVE KNOWN THAT SUCH DAMAGES WERE POSSIBLE AND EVEN IF DIRECT DAMAGES DO NOT SATISFY A REMEDY.

---

For technical support please contact [support@pulsar-vision.com](mailto:support@pulsar-vision.com).

Answers to frequently asked questions about the devices can also be found in the **FAQ** section.