

ACCOLADE 2 LRF Manual

Specifications

About The Device

- Description
- Components and controls
- Features
- Button operation
- Package contents

Power supply

- Battery charging
- External power supply
- Battery installation
- Safety measures

Getting started

- Quick menu functions
- Status bar
- Discrete digital zoom
- Microbolometer calibration
- Powering on and image settings

Interface

- General settings
- Wi-fi settings
- PIP mode
- Calibration mode
- Color modes
- Icon brightness
- Mode
- Image detail boost
- Wi-fi activation
- Enter the main menu
- Remote control
- Rangefinder
- Microphone

Functions

- Display-off function
- Built-in laser rangefinder
- Wi-fi function
- Video recording and photography

Software

- Wireless remote control

USB connection

Firmware update

Stream vision

Maintenance

Technical maintenance and storage

Technical inspection

Troubleshooting

Support

Legal compliances and disclaimers

Specifications

Model XP50 PRO

SKU 77461

Microbolometer

Type uncooled

Resolution, pixels 640×480

Pixel Pitch, μm 17

NETD, mK < 25

Frame rate, Hz 50

Optical Characteristics

Magnification, x 2.5

Continuous digital zoom, x 2.5-20

Digital zoom 2x/4x/8x

Objective lens 1:1.2

Close-up range, m / y 3 / 3.28

Exit pupil diameter, mm 5

Field of view (H), degrees / m@100m 12.4 / 21.8

Diopter adjustment, D ± 5

Interpupillary distance adjustment, mm 56-71

Range of detection (deer type object), m (y) 1800 / 1970

Display

Type	AMOLED
Resolution, pixels	640×480
Operational Characteristics	
Power supply, V	3.7
Battery type / Capacity / Output voltage	Li-Ion Battery Pack IPS7 / 6400 mAh / DC 3.7V (3.0-4.2)
External power supply	5V
Operating time on Battery Pack (at t=22°C), h*	9
Degree of protection, IP code (IEC60529)	IPX7
Operating temperature range, °C /° F	-25 ... +50 / -13 ... 122
Dimensions, mm / inch	164 x 130 x 64 / 6.46 x 5.12 x 2.52
Weight (without battery), kg / oz	0.6 / 21.2
Video Recorder	
Video / photo resolution, pixel	640×480
Video / photo format	.avi / .jpg
Built-in memory	16 Gb
Built-in memory capacity	650 minutes of video or more than 100 000 photos
Wi-Fi Channel**	
Frequency	2.4 GHz
Standard	802.11 b/g
Characteristics of the Rangefinder	
Safety class for laser equipment according to BS / EN 60825-1: 2014	1
Wavelength, nm	905
Max. measuring range***, m/y	1000 / 1094
Measurement accuracy, m	+/-1

*Actual operating time depends on the extent of using Wi-Fi, integrated video recorder and integrated laser rangefinder.

**The reception range may vary depending on various factors: obstacles, other Wi-Fi networks.

***Depends on the characteristics of the object under observation and environmental conditions.

About The Device

Description

Accolade 2 LRF Pro thermal binoculars are based on an IR sensor (uncooled microbolometer) and are designed for comfortable viewing with both eyes.

Accolade 2 LRF Pro scopes accommodate day and nighttime observations. **Accolade 2 LRF Pro** Binoculars provide exceptional image quality even in adverse weather conditions (fog, smog, rain) and beyond obstacles like branches, tall grass, dense foliage, etc. known to hinder target detection.

Accolade 2 LRF Pro devices do not require an external light source and are not affected by bright light exposure.

These binoculars are equipped with a precise built-in laser rangefinder capable of measuring distances up to 1000 m accurately (± 1 m).

Accolade 2 LRF Pro Thermal Imaging Binoculars are perfectly suited for night hunting, observation, trail orientation, identifying hazards, rescue operations, etc.

Components and controls

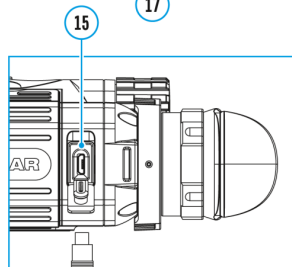
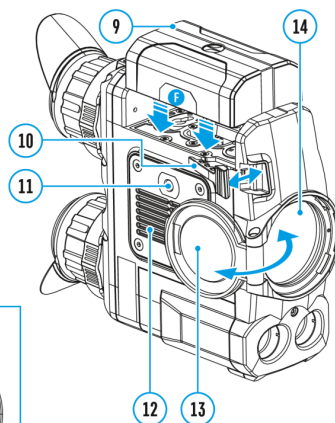
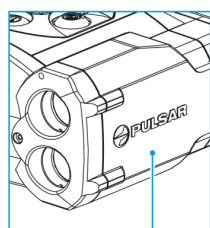
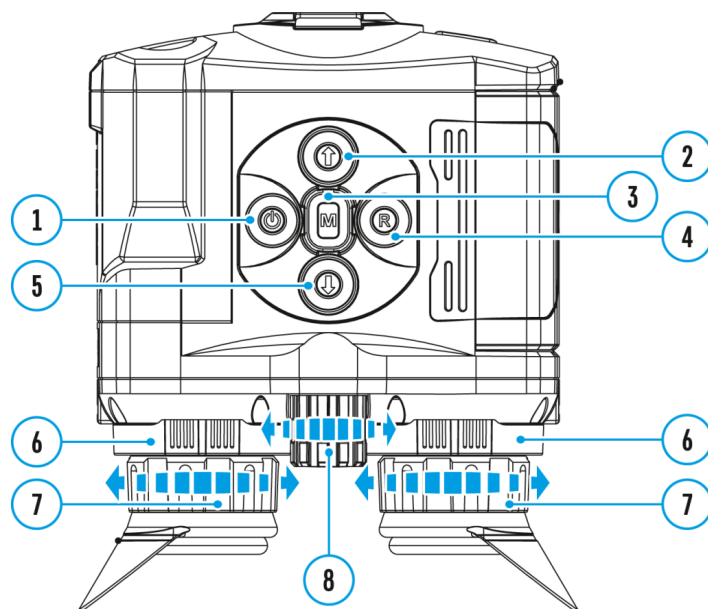

1. Power ON/OFF/Calibration button
2. Navigation button UP
3. Button MENU
4. Recording button REC
5. Navigation button DOWN
6. Interpupillary distance adjustment rings
7. Diopter adjustment rings
8. Lens focusing ring
9. Battery Pack

10. Battery Pack latch
11. Tripod mount
12. Radiator cooling system
13. Lens cover
14. Objective lens
15. MicroUSB port
16. MicroUSB cable
17. Integrated laser rangefinder

Features

- NETD less than 25 mK
- Built-in laser rangefinder (up to 1000 m)
- Variable interpupillary distance
- High refresh rate 50 Hz
- Built-in video recorder
- Integral Wi-Fi module
- Wi-Fi video transmission
- Frost resistant AMOLED display
- Quick-change, long-life rechargeable Battery Packs
- Fully waterproof IPX7

Extra features:

- Picture-in-Picture mode
- 8 color palettes
- 4 observation modes
- 3 calibration modes
- Manual contrast and brightness adjustment

Button operation

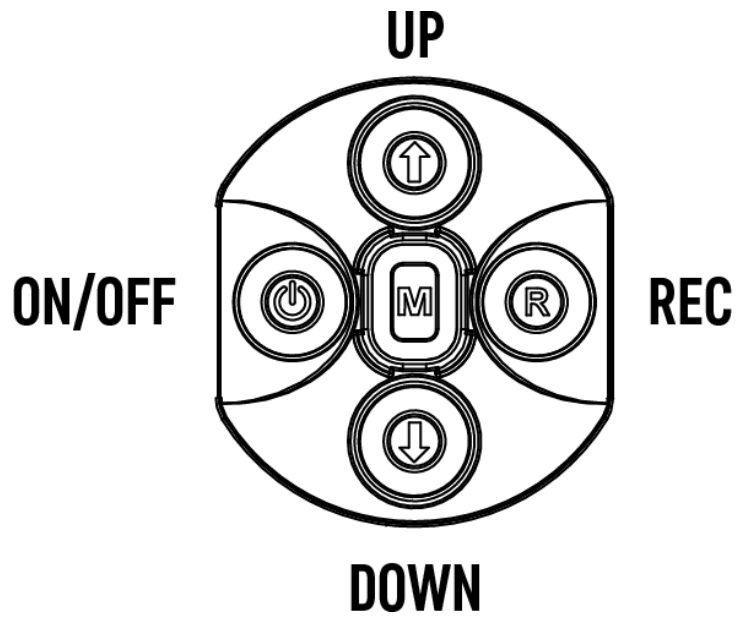

Operation

Button

Power device on

short press

Power device off

long press for 3 secs

Turn display off

long press for less than 3 secs

Turn display on

short press

Calibrate the microbolometer

short press

Control discrete digital zoom

short press

Change observation modes

long press

Video Recorder

Button

Start/pause/resume video recording

R
short press

Stop video recording

R
long press

Switch to video / photo

R
long press

Capture Photo

R
short press

Main Menu

Button

Enter main menu

M
long press

Navigation upwards/rightwards

↑
short press

Navigation downwards/leftwards

↓
short press

Confirm selection

M
short press

Exit submenu without confirming selection

M
long press

Exit menu (switch to viewing mode)

M
long press

Quick Menu

Button

Enter quick menu

M
short press

Switch between quick menu options

M
short press

Increase value

↑
short press

Decrease value

↓
short press

Exit quick menu

M
long press

Rangefinder

Button

Activate rangefinder



short press

Measure distance



short press

Start/stop SCAN mode



long press

Package contents

- Accolade 2 LRF Pro thermal binocular
- IPS7 rechargeable battery
- Battery Charger
- Power adapter
- Micro USB cable
- Carrying case
- Neck strap
- Quick-Start guide
- Lens cloth
- Warranty card

Power supply

Battery charging

Accolade 2 LRF Pro thermal imaging binoculars are supplied with a rechargeable Li-Ion Battery Pack IPS7 which allows operation for up to 9 hours. Please remember to charge the Battery Pack before first use.

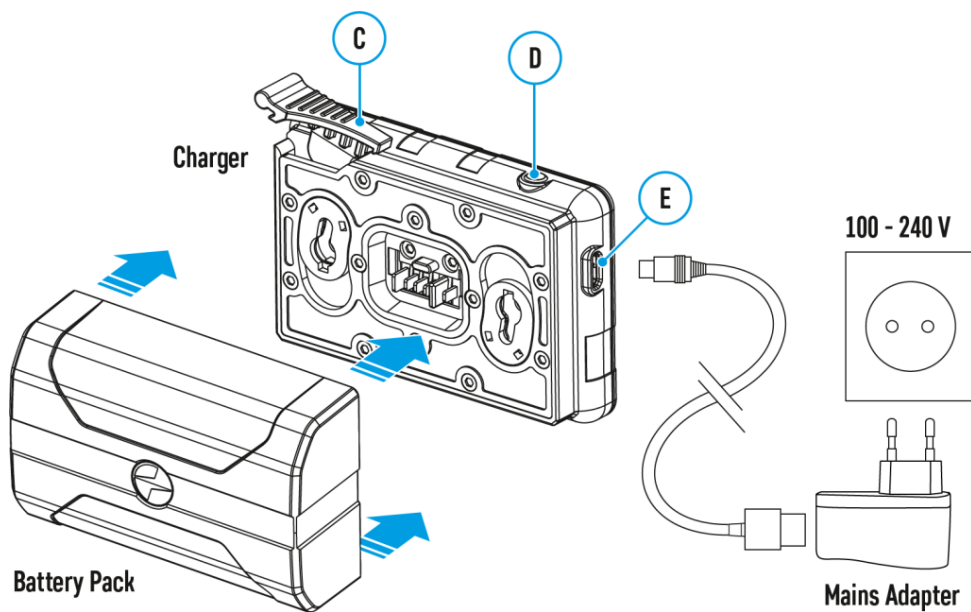

Charging



Step 1. Install the battery into the charger

1. Lift the lever **(C)** of the charger.
2. Remove the protective cover from the Battery Pack.
3. Install the Battery Pack into the charger.
4. Click the lever **(C)**.

Step 2. Check the current battery level

- Upon installation, a green LED indicator **(D)** on the charger will start to glow and begin flashing:
 - once if the battery charge ranges from 0% to 50%;
 - twice if the battery charge ranges from 51% to 75%;
 - three times if the battery charge ranges from 76% to 100%;
- If the indicator lights green continuously, the battery is fully charged.
- You can remove the battery from the charger by lifting the lever **(C)**.
- If the indicator of the charger lights red continuously upon battery installation, probably the battery's charge level is lower than acceptable (the battery has been long in deep discharge). Keep the battery in the charger for a long time (up to several hours), remove and re-insert it.
- If the indicator starts blinking green, the battery is good.
- If the indicator keeps lighting red, the battery defective. **Do not use the battery!**

The LED indicator (D) will display the battery charge status:

LED Indicator	Battery Charge Status
	Battery is empty
	Battery is full

Step 3. Connect the charger to the mains supply

1. Connect the Micro-USB plug of the USB cable to the port **(E)** of the charger.
2. Connect the Micro-USB plug to the power adapter.
3. Insert the plug of the power adapter to the 100-240 V socket.

External power supply

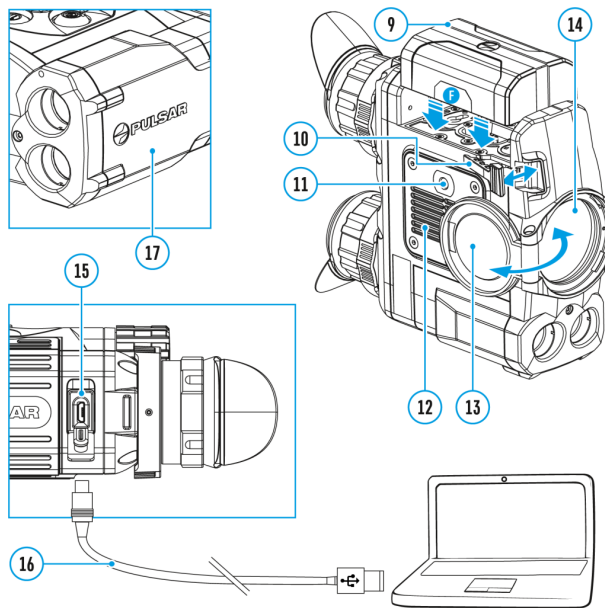
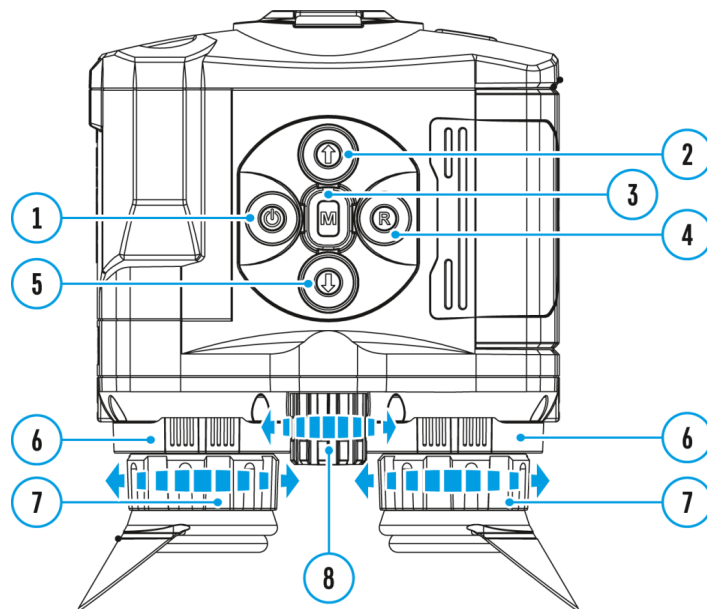

The device can be powered with an external power supply such as Power Bank (5 V).

1. Connect the external power supply to the USB port **(15)** of the device.
2. The device switches to operation from external power supply, and the IPS7 Battery Pack will begin slowly charging.
3. The display will show the battery icon



with charge level as a percentage.

4. If the device operates on external power supply but the IPS7 battery is not connected, icon



is shown.

5. When the external power supply is disconnected, the device switches to the internal battery pack without powering off.

Warning! Charging IPS7 / IPS14 batteries at air temperatures below 0° C (32° F) may reduce battery life. When using external power, connect the Power Bank to the device after it has been turned on and working for several minutes.

Battery installation

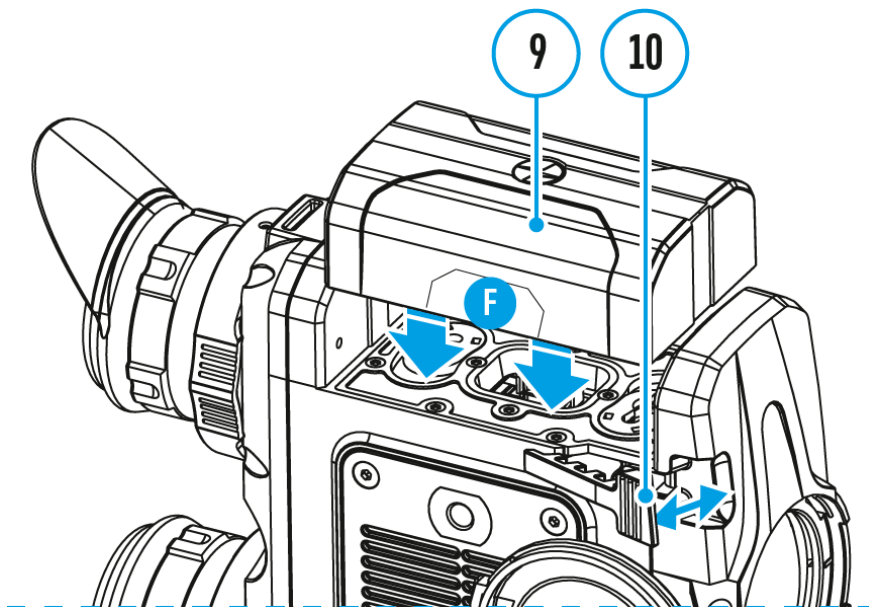

1. Lift the lever **(10)**.
2. Install the battery **(9)** all the way into the dedicated slot on the device housing so that element **F** appears from below.
3. Fix the battery by clicking the lever **(10)**.

Safety measures

- Only use the charger supplied with the Battery Pack. The use of any other charger may irreparably damage the Battery Pack or the charger and may cause fire.
- During long-term storage, the Battery Pack should be partially charged – the charge level should be between 50% and 80%.
- Do not charge the Battery Pack immediately after bringing it from a cold environment to a warm one. Wait for 30-40 minutes for the Battery Pack to get warm.
- Charge the Battery Pack at a temperature from 0° C to +45° C (32° F to +113° F), otherwise the battery life will decrease significantly.
- Do not leave the Battery Pack unattended while charging.
- Never use a modified or damaged charger.
- Do not leave the Battery Pack with a charger connected to the power adapter after charging is complete.
- Do not expose the Battery Pack to high temperatures or an open flame.
- Do not submerge the Battery Pack in water.
- Do not connect an external device with a current consumption that exceeds permitted levels.
- The Battery Pack is short circuit protected; however, any situation that may cause short-circuiting should be avoided.
- Do not dismantle or deform the Battery Pack.
- Do not drop or hit the Battery Pack.
- When using the Battery Pack at sub-zero (sub 32°F) temperatures the battery capacity decreases. This is normal and is not a defect.
- Do not use the Battery Pack at temperatures above those shown in the table – this may decrease battery life.
- Keep the Battery Pack out of the reach of children.

Getting started

Quick menu functions

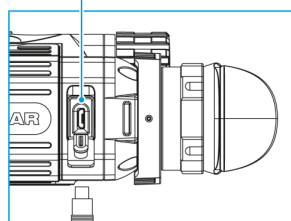
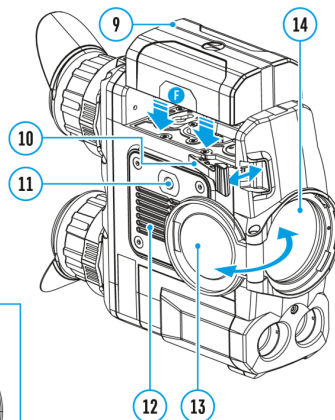
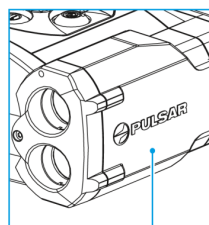
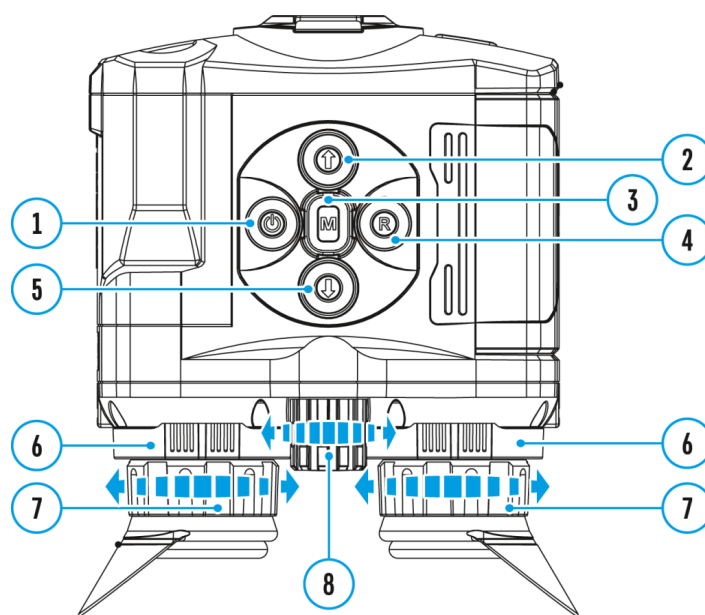

The quick menu allows change of basic settings such as display brightness and contrast, smooth digital zoom.

- Enter the menu with a short press of the **Menu (3)** button.
- To toggle between the functions below, press successively the **Menu (3)** button.

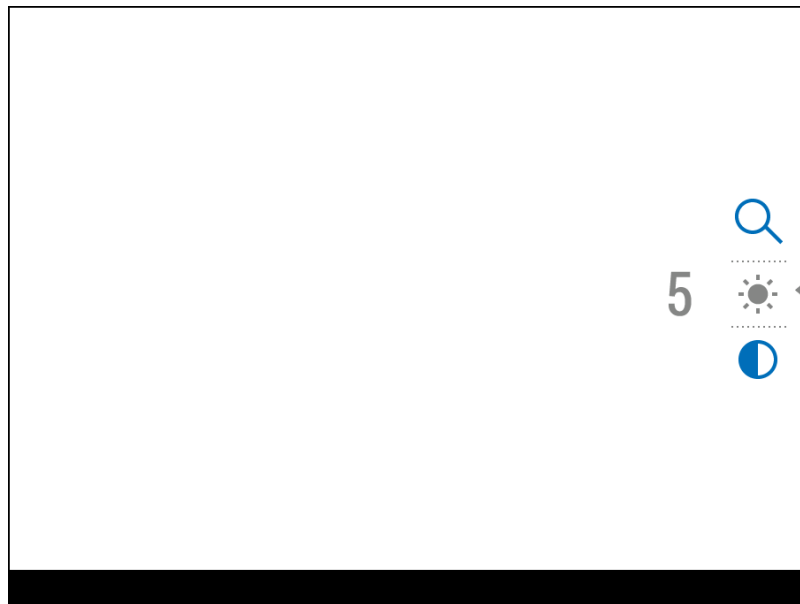

Brightness

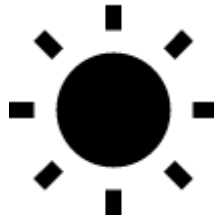

– press briefly the **UP (2)/DOWN (5)** buttons to change display brightness from 0 to 20.

Contrast



– press briefly the **UP (2)/DOWN (5)** buttons to change display contrast from 0 to 20.

Base mode



– it allows you to select one of the three observation modes (Forest, Rocks, Identification) as a base for the User mode.

Smooth digital zoom



– press the **UP (2)/DOWN (5)** buttons to change digital zoom from 2.5 to 20.

Smooth digital zoom is in 0.1x increments.

- To exit quick menu, press and hold down the **Menu (3)** button or wait 5 sec for automatic exit.

Status bar



The status bar at the bottom of the display shows current operating statuses via icons, including:

1. Color palette (shown only if the **"Black Hot"** palette is selected)
2. Observation mode
3. Calibration mode (in the automatic calibration mode, three seconds before automatic calibration a countdown timer



is shown in place of the calibration mode icon).

4. Current full magnification (for example, 16x)
5. Wi-Fi connection status
6. Time
7. Power indication:
 - Battery charge level



(if the device is powered by the Battery Pack).

- External battery power indicator



(if the device is powered by an external power supply).

Discrete digital zoom

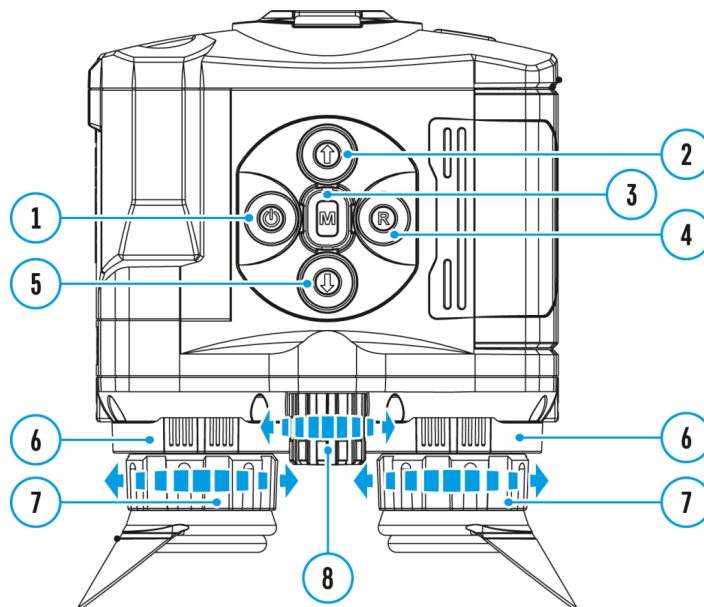

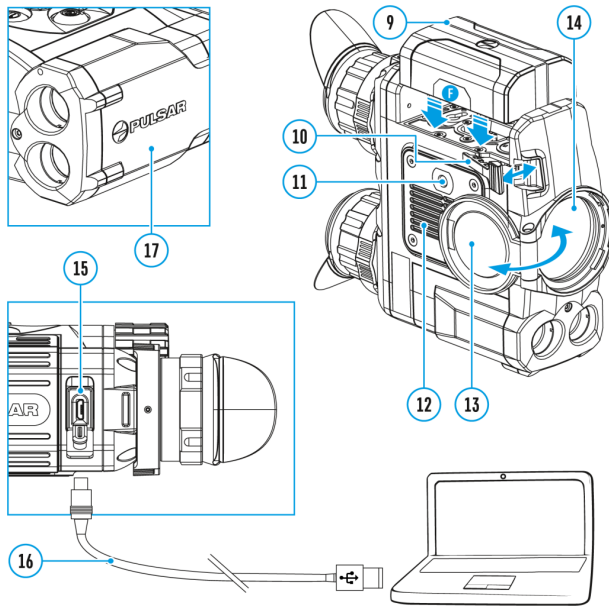

The device allows you to quickly increase the basic magnification (please refer to the **Magnification** line in the **Specifications** table) by 2, 4 or 8 times.

- To operate the discrete digital zoom, press successively the **DOWN (5)** button.
- The digital zoom will not be saved after the device is re-started.

Microbolometer calibration

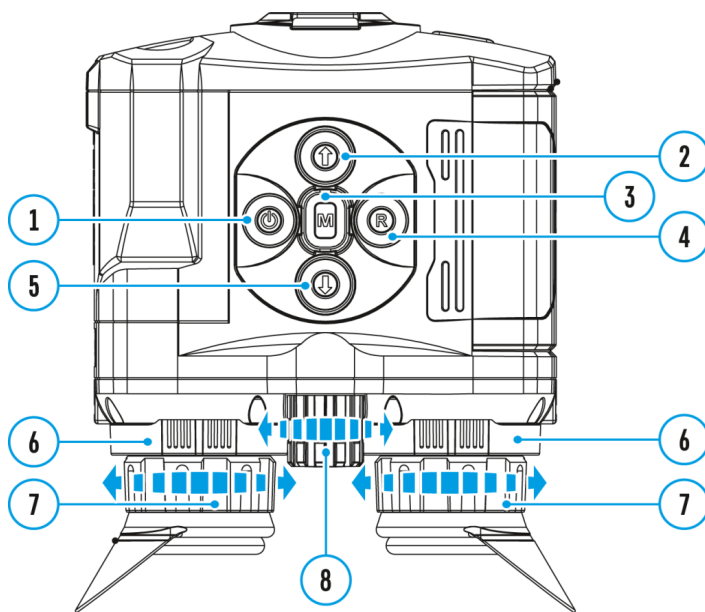

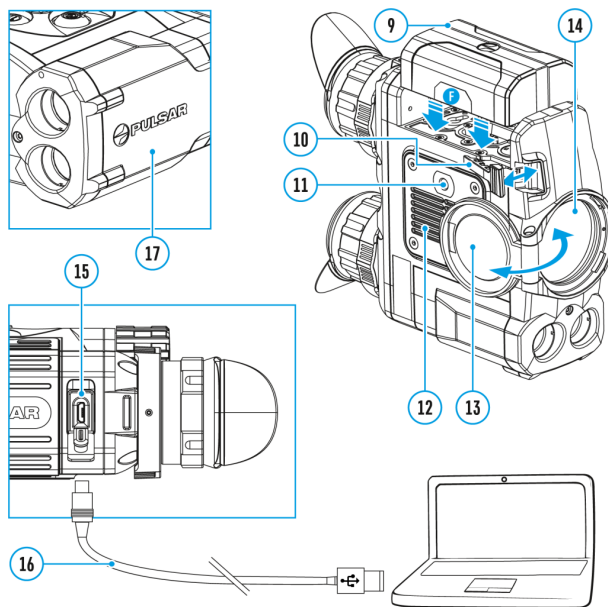

Calibration eliminates image flaws (such as vertical bars, phantom images, grainy field of view, etc.) by equalizing the microbolometer background temperature.

There are three calibration modes: **manual (M)**, **semi-automatic (SA)** and **automatic (A)**.

Select the desired mode in the menu option **Calibration Mode**



Mode M (manual)

- Close the lens cover.
- Press briefly the **ON/OFF (1)** button.
- Open the lens cover.

Mode SA (semi-automatic)

- Press briefly the **ON/OFF (1)** button to calibrate.
- You do not need to close the lens cover (the microbolometer is closed with the internal shutter automatically).

Mode A (automatic)

- The device calibrates by itself according to the firmware algorithm.

- You do not need to close the lens cover (the microbolometer is closed with the internal shutter automatically).
- In the automatic mode, the user can calibrate the microbolometer with the **ON/OFF (1)** (in the **SA** mode) button.
- In the automatic calibration mode, three seconds before automatic calibration a countdown timer

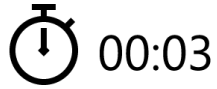

is shown in place of the calibration mode icon.

Powering on and image settings

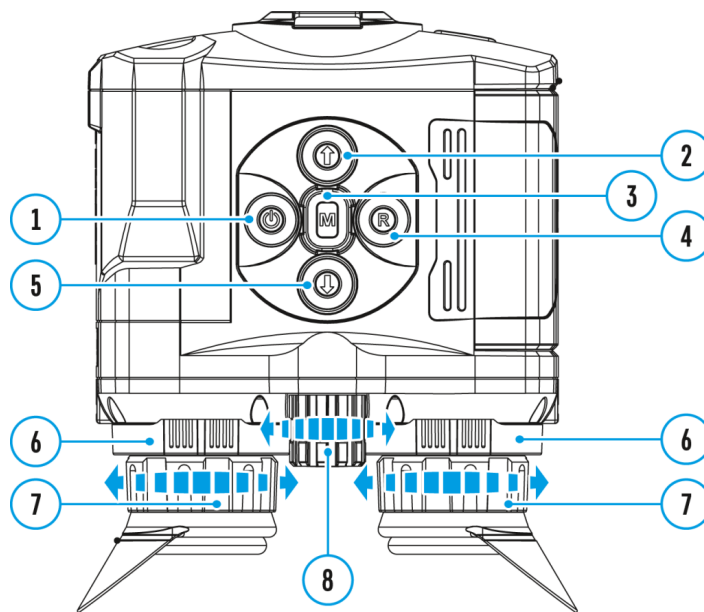

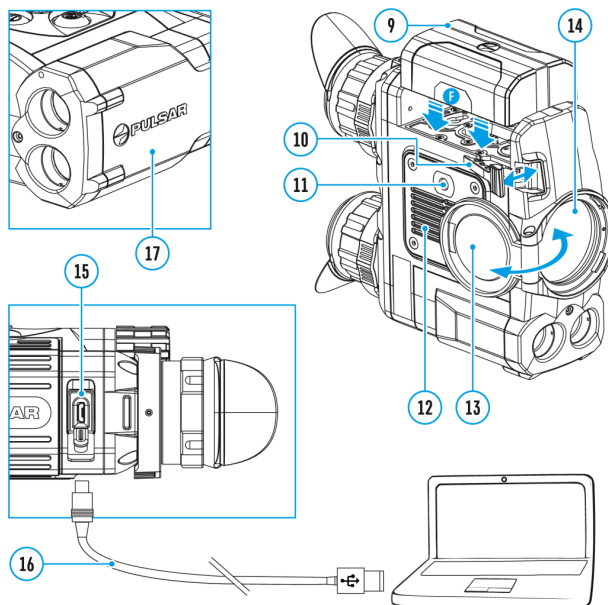

1. Open the lens cover **(13)**.
2. Turn the device on with a short press of the **ON/OFF (1)** button.
3. Adjust the interpupillary distance with the rings **(6)** by moving the eyepieces farther or closer to each other.
4. To obtain a crisp image of the icons on the display, rotate the diopter adjustment ring **(7)**. Once adjusted, there is no need to rotate the diopter adjustment ring for distance or any other conditions.
5. To focus on the object being observed rotate the lens focusing ring **(8)**.
6. Select the calibration mode: **manual (M)**, **semi-automatic (SA)** or **automatic (A)** in the main menu (enter the menu by long pressing the **MENU (3)** button).
7. Calibrate the image with a short press of the **ON/OFF (1)** button (when calibration mode **(SA)** or **(M)** has been selected). Close the lens cap before manual calibration.
8. Select the desired observation mode (**Forest, Rocks, Identification** or **User**) by a long press of the **DOWN (5)** button or in the main menu. User mode allows you to configure and save custom
9. To set up display brightness and contrast and continuous zoom, please refer to the **Quick Menu Functions** section.
10. After use, press and hold down the **ON/OFF (1)** button to turn the device off.

Warning! Never point the lens at intensive energy sources such as laser radiation emitting devices or the sun. It can damage electronic components in the device. The warranty does not cover damage arising from failure to comply with operating instructions.

Warning! The radiator cooling system **(12)** becomes warm during operation: this is normal and allows an increase in the sensitivity of the device.

Interface

General settings

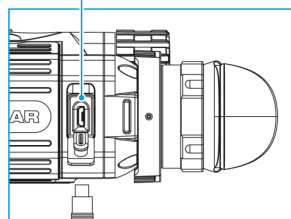
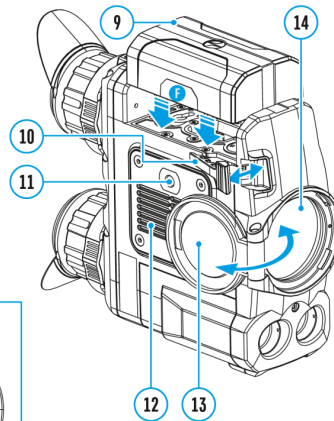
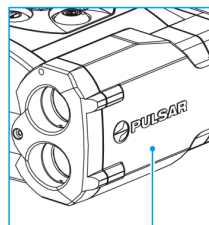
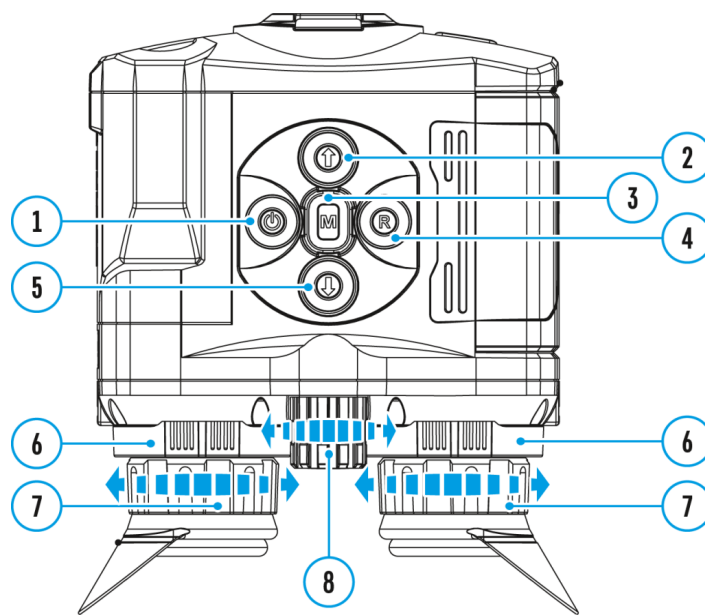

1. Press and hold down the **Menu (3)** button to enter the main menu.
2. Select option **General Settings**



with the **UP (2)/DOWN (5)** buttons.

3. Press briefly the **Menu (3)** button to confirm.

The following settings are available:

Language

Selecting interface language

1. Select option **Language**



with the **UP (2)/DOWN (5)** buttons.

2. Press briefly the **Menu (3)** button to confirm.
3. Select one of the available interface languages with a short press of the **UP (2)/DOWN (5)** buttons: English, French, German, Spanish, Russian.
4. Press briefly the **Menu (3)** button to confirm.

Date

Date setup

1. Select option **Date**



with **UP (2)/DOWN (5)** buttons.

2. Press briefly the **Menu (3)** button to confirm. Date format is displayed as: YYYY/MM/DD (year/month/day)
3. Select the correct values for the year, month and date with a short press of the **UP (2)/DOWN (5)** buttons.
4. Switch between digits with a short press of the **Menu (3)** button.
5. Save selected date and exit the submenu with a long press of the **Menu (3)** button.

Time

Time setup

1. Select option **Time**



with **UP (2)/DOWN (5)** buttons.

2. Press briefly the **Menu (3)** button to confirm.
3. Select the desired time format with a short press of the **UP (2)/DOWN (5)** buttons: 24 or PM/AM.
4. Switch to hour setup with a brief press of the **Menu (3)** button.
5. Select hour value with a brief press of the **UP (2)/DOWN (5)** buttons.
6. Switch to minute setup with a brief press of the **Menu (3)** button.
7. Select minute value with a brief press of the **UP (2)/DOWN (5)** buttons.
8. Save selected time and exit the submenu with a long press of the **Menu (3)** button.

Units of Measure

Selection of units of measurement

1. Select option **Units of Measure**



with **UP (2)/DOWN (5)** buttons.

2. Press briefly the **Menu (3)** button to confirm.

3. Select the desired unit of measurement – meters or yards – with **UP (2)/DOWN (5)** buttons.
4. Press briefly the **Menu (3)** button to confirm.
5. Exit to general settings submenu takes place automatically.

Default Settings

Restore default settings

1. Select option **Default Settings**



with **UP (2)/DOWN (5)** buttons.

2. Press briefly the **Menu (3)** button to confirm.
3. With a short press of the **UP (2)/DOWN (5)** buttons select **"Yes"** to restore default settings or **"No"** to abort.
4. Confirm selection with a brief press of the **Menu (3)** button.
 - If **"Yes"** is selected, display will show **"Do you want to restore default settings?"** and **"Yes"** and **"No"** options. Select **"Yes"** to restore default settings.
 - If **"No"** is selected, action is aborted and you return to the submenu.

The following settings will be restored to their original values before changes made by the user:

- **Video recorder mode** – video
- **Observation mode** – forest
- **Calibration mode** – automatic
- **Language** – English
- **Mictophone** – off
- **Wi-Fi** – off (default password)
- **Magnification** – off (no digital zoom)
- **PiP** – off
- **Color mode** – White Hot
- **Unit of measurement** – metric

Warning: date and time settings, default pixel map and remote control activation are not restored.

Format

This item allows you to format the Flash-card (memory card) of the device (this will delete all files from the memory card).

1. Select option **Format**



with **UP (2)/DOWN (5)** buttons.

2. Press briefly the **Menu (3)** button to confirm.
3. With a short press of the **UP (2)/DOWN (5)** buttons select **"Yes"** to format the memory card or **"No"** to return to the submenu.
4. Confirm selection with a short press of the **Menu (3)** button.
 - If **"Yes"** is selected, display will show **"Do you want to format memory card?"** and **"Yes"** and **"No"** options. Select **"Yes"** to format the memory card.
 - If **"No"** is selected, formatting is aborted and you return to the submenu.

Wi-fi settings

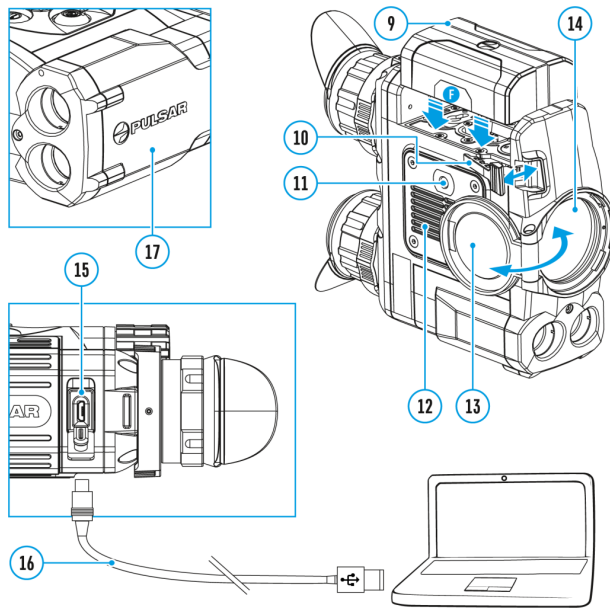
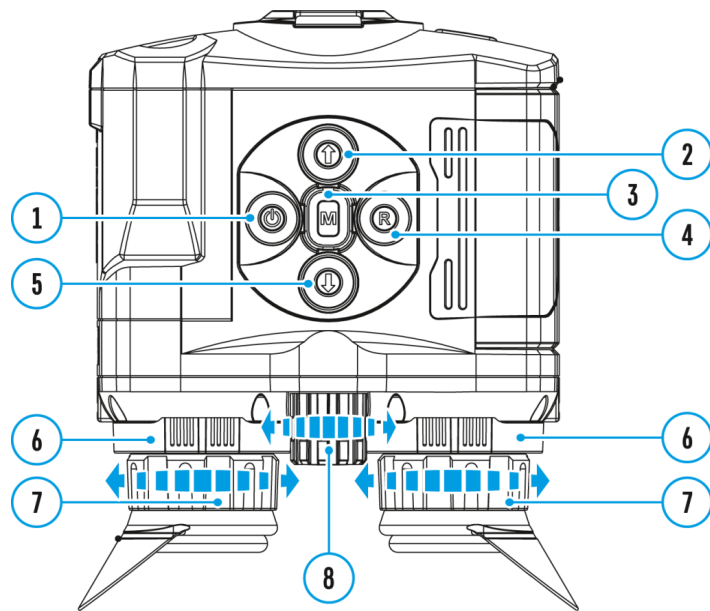

This menu option allows you to set up your device for operation in a Wi-Fi network.

1. Press and hold down the **Menu (3)** button to enter the main menu.
2. Select the **Wi-Fi Settings**



menu option with the **UP (2)/DOWN (5)** buttons.

3. Press briefly the **Menu (3)** button to enter submenu.

4. Select the desired menu item with the **UP (2)/DOWN (5)** buttons.

Password Setup

This menu option allows you to set a password to access your binoculars from an external device.

The password is used to connect an external device (i.e. smartphone) to your thermal imager.

1. Press briefly the **Menu (3)** button to enter the **Password Setup**



submenu.

2. The default password **(12345678)** will appear on the screen.
3. Set the desired password with the **UP (2)/DOWN (5)** buttons.
4. Switch between digits with a short press of the **Menu (3)** button.
5. Save the password and exit the submenu with a long press of the **Menu (3)** button.

Access Level Setup

This menu option allows you to set required access level of the Stream Vision application to your device.

- Access level **Owner**. The Stream Vision user has the complete access to all device's functions.
- Access level **Guest**. The Stream Vision user has the access only to the real time video stream from the device.

1. Press briefly the **Menu (3)** button to enter the **Access Level Setup**



submenu.

2. Select the access level with the **UP (2)/DOWN (5)** buttons.
3. Press and hold the **Menu (3)** to confirm your selection and exit from the submenu.

PIP mode

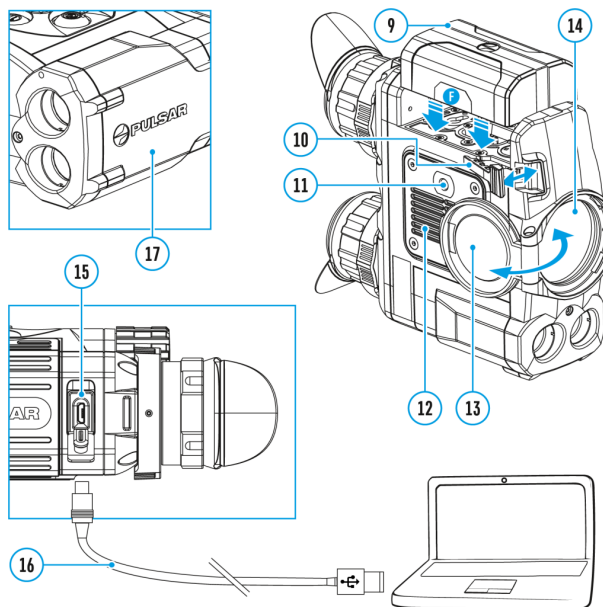
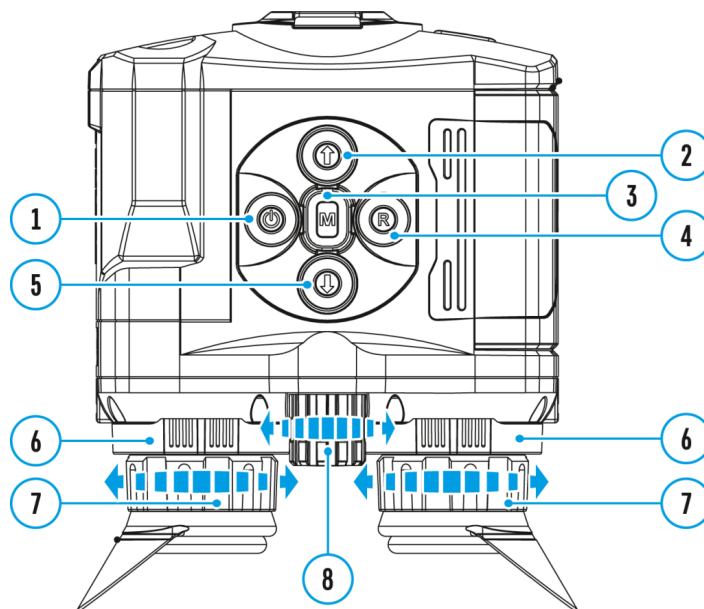

Selection of the Picture in Picture Mode

1. Press and hold the **Menu (3)** button to enter the menu.
2. Select the **PiP Mode**



option with the **UP (2)/DOWN (5)** buttons.

3. A short press of the **Menu (3)** button switches the mode on/off.

Calibration mode

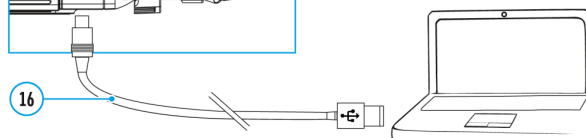
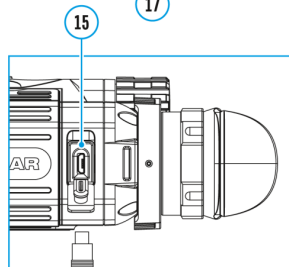
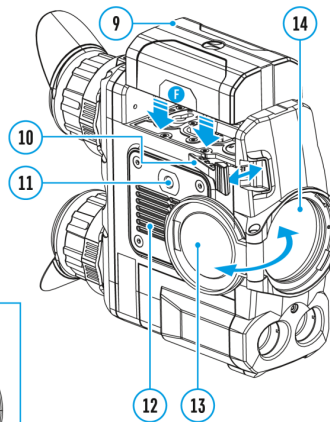
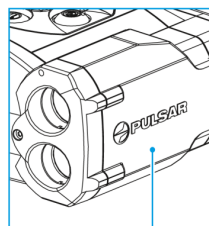
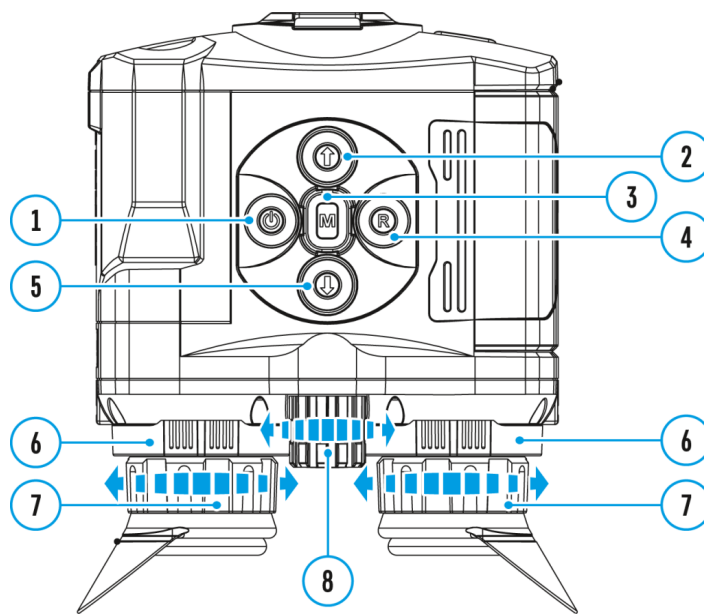

There are three calibration modes: **manual (M)**, **semi-automatic (SA)** and **automatic (A)**.

1. Press and hold down the **Menu (3)** button to enter the main menu.
2. Select the **Calibration Mode**



option with the **UP (2)/DOWN (5)** buttons.

3. Press briefly the **Menu (3)** button to enter submenu.
4. Select the desired calibration mode with the **UP (2)/DOWN (5)** buttons.
5. Confirm your selection with a brief press of the **Menu (3)** button.

More details in the section **Microbolometer Calibration**.

Color modes

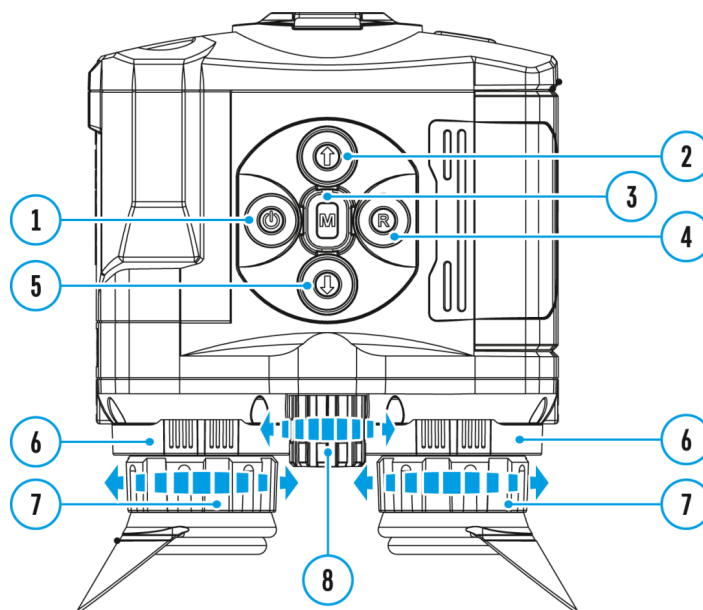

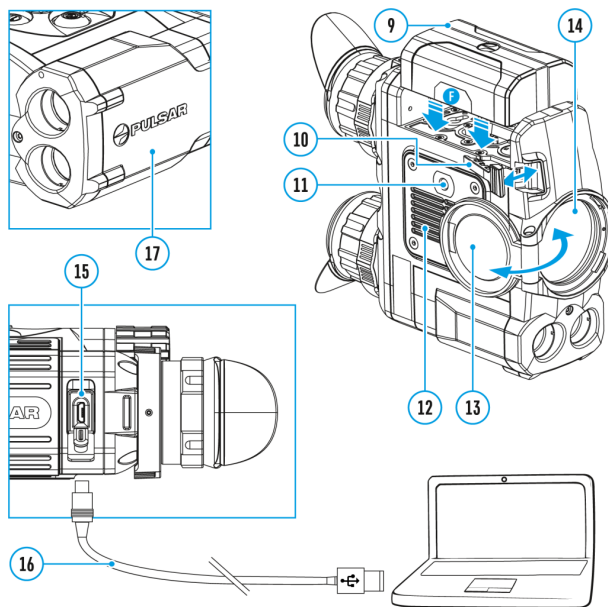

Basic color mode is **White Hot**.

To select another palette:

1. Press and hold down the **Menu (3)** button to enter the main menu.
2. Select the **Color Modes**



icon with the **UP (2)/DOWN (5)** buttons.

3. Press briefly the **Menu (3)** button to enter submenu.
4. Select the desired palette with the **UP (2)/DOWN (5)** buttons.
5. Confirm your selection with a brief press of the **Menu (3)** button.

- **Black Hot** (white color corresponds to low temperature, black color – to high temperature)
- **Red Hot**
- **Red Monochrome**
- **Rainbow**
- **Ultramarine**
- **Violet**
- **Sepia**

Note: to quickly change color modes press and hold the **UP (2)** button.

Icon brightness

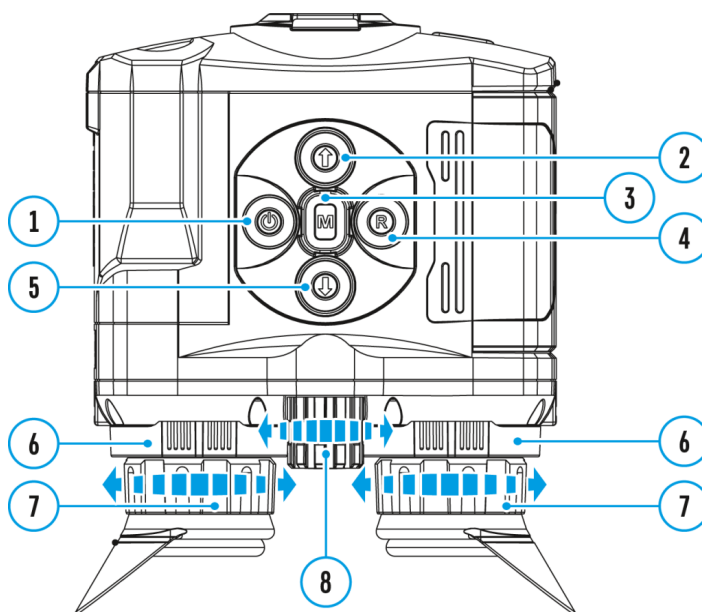

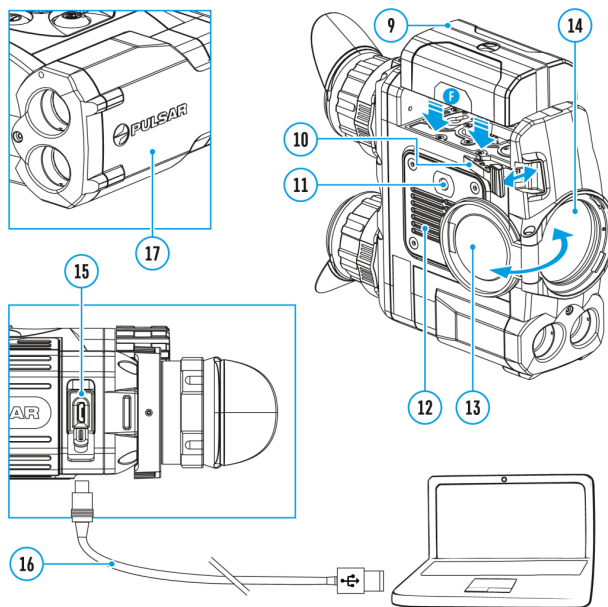

Icon brightness

1. Press and hold the **Menu (3)** button to enter the main menu.
2. Use the **UP (2)/DOWN (5)** buttons to select the **Icon Brightness** icon



3. Press the **Menu (3)** button briefly to enter the submenu.
4. Use the **UP (2)/DOWN (5)** buttons to select the desired brightness level from 0 to 10.
5. Press the **Menu (3)** button briefly to confirm the selection.

Mode

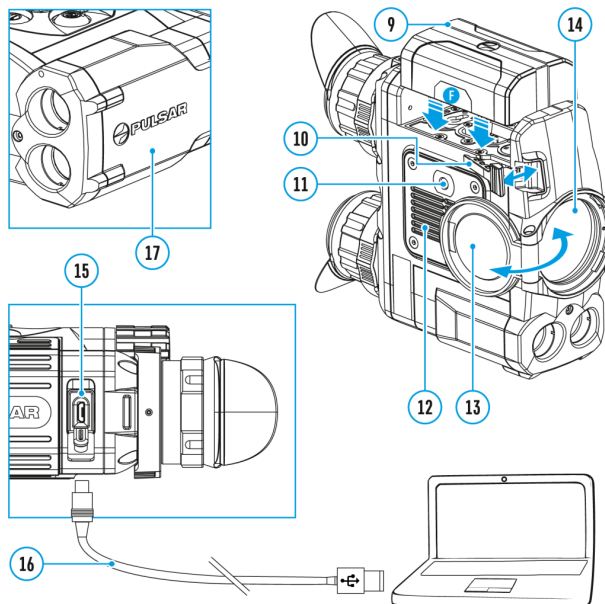
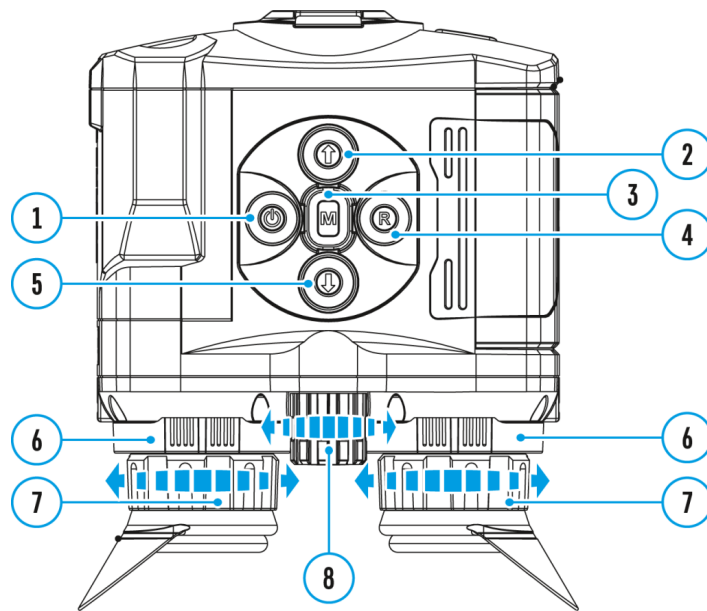

The devices have four observation modes of the thermal imager: Forest (observation mode of objects within low thermal contrast conditions), Rocks (observation mode of objects within high thermal contrast conditions), Identification (high detalization mode), User (individual brightness and contrast settings).

1. Press and hold the **Menu (3)** button to enter the menu.
2. Select the **Mode**



option with the **UP (2)/DOWN (5)** buttons.

3. A short press of the **Menu (3)** button opens the menu.
4. Select one of the settings described below with the **UP (2)/DOWN (5)** buttons.

5. A short press of the **Menu (3)** button confirms the selection.



Forest – This is the best mode when searching and observing within field conditions, against the background of leaves, bushes and grass. The mode is highly informative about an object being observed as well as landscape details.



Rocks – This is the best mode when observing objects after a sunny day or within urban conditions.



Identification – This is the best mode when observing objects within adverse weather conditions (fog, mist, rain and snow). It allows you to recognize the characteristics of an object being observed more clearly. Zoom increase may be accompanied by insignificant image graininess.



User – It allows you to configure and save custom brightness and contrast settings, as well as one of the three modes (Forest, Rocks, Identification) as basic.

Note: to quickly change observation modes press and hold the **DOWN (5)** button.

Image detail boost

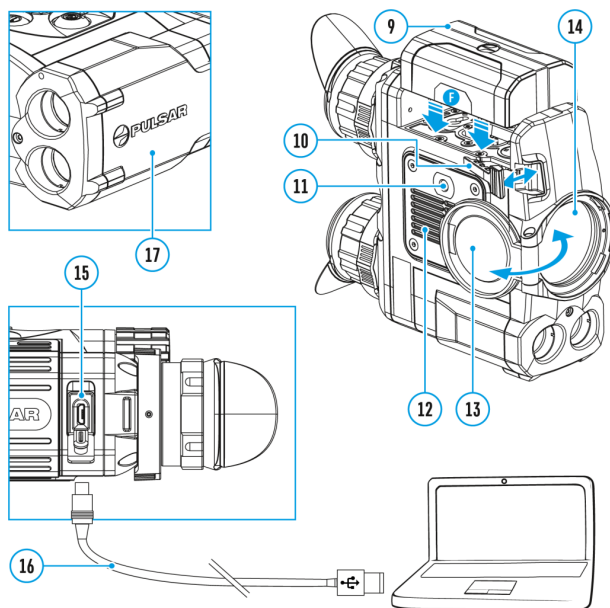
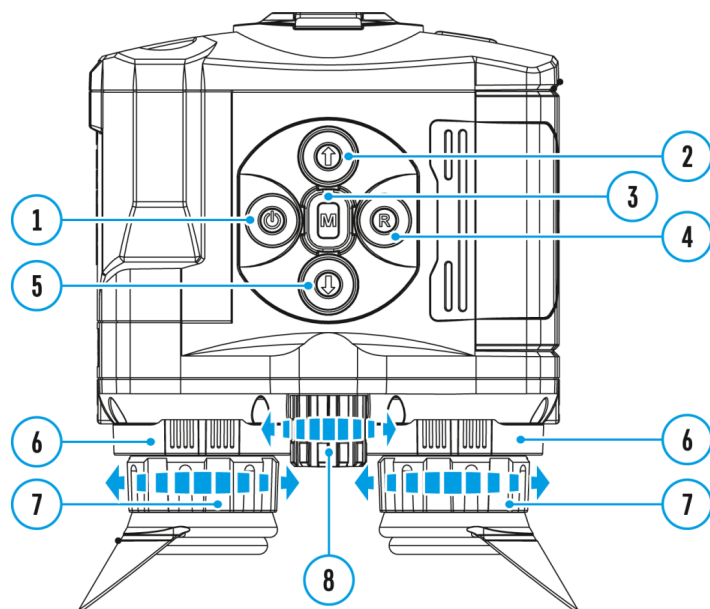

The **Image Detail Boost**



function increases the sharpness of the contours of heated objects, which increases their detail. The result of the function depends on the selected mode and observation conditions: the higher the contrast of objects, the more noticeable the effect. This option is enabled by default, but can be disabled in the main menu.

Turn on/off Image Detail Boost:

1. Press and hold down the **Menu (3)** button to enter the main menu.
2. Select the **Image Detail Boost**



menu option with the **UP (2)/DOWN (5)** buttons.

3. Turn Image Detail Boost on/off with a short press of the **Menu (3)** button.

Wi-fi activation

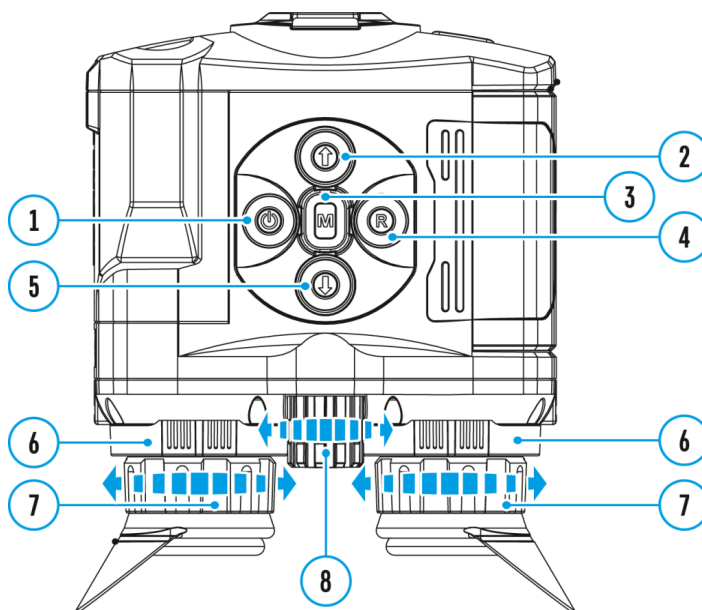

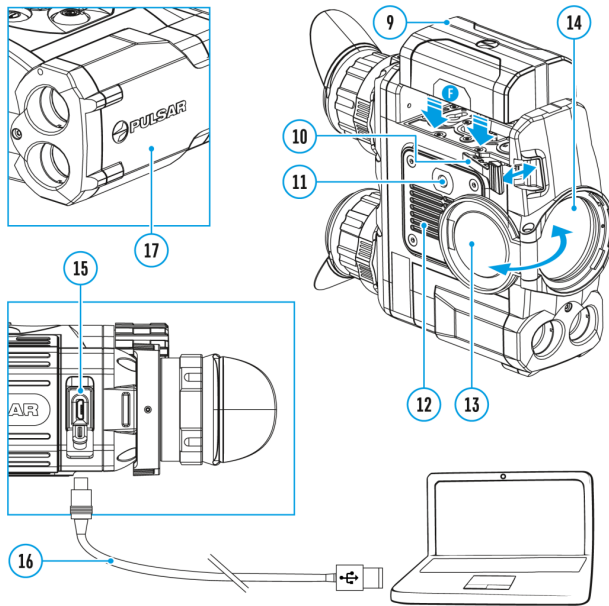

1. Press and hold down the **Menu (3)** button to enter the main menu.
2. Select the **Wi-Fi Activation**



menu option with the **UP (2)/DOWN (5)** buttons.

3. Turn Wi-Fi on/off with a short press of the **Menu (3)** button.

Enter the main menu

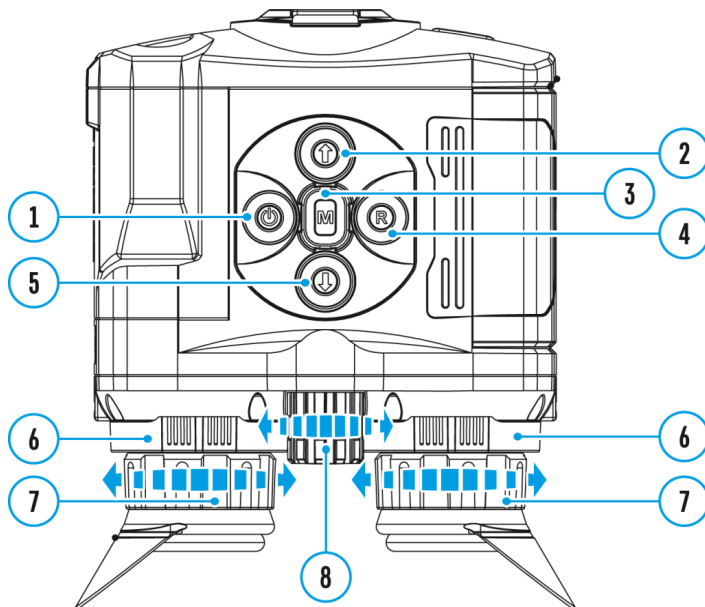

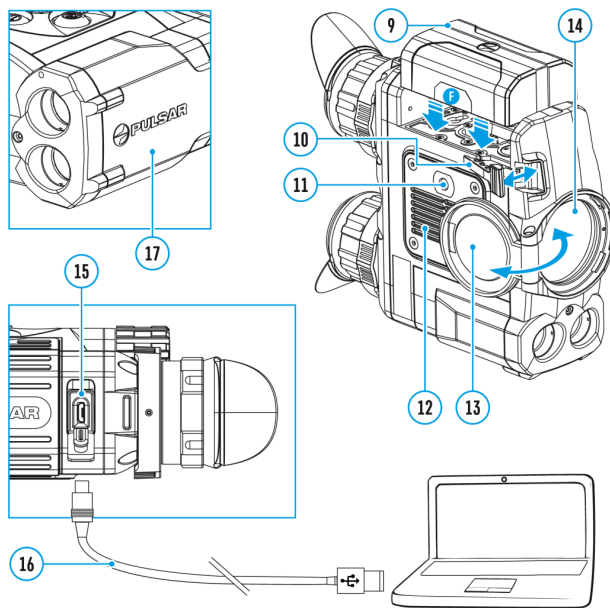

1. Enter the main menu with a long press of the **Menu (3)** button.
2. Press the **UP (2)/DOWN (5)** buttons to switch between the menu options.
3. Enter a menu option with a brief press of the **Menu (3)** button.
4. Exit the menu with a long press of the **Menu (3)** button.
5. Automatic exit takes place in 10 sec of inactivity (buttons are not pressed).

General View of the Menu

Tab 1

Menu	Wi-Fi activation
<ul style="list-style-type: none"> Wi-Fi > Down Arrow > Up Arrow > 	<ul style="list-style-type: none"> On <input type="checkbox"/> Off <input type="checkbox"/> Rocks Forest Identification User
<ul style="list-style-type: none"> 10 Color Wheel > 	<ul style="list-style-type: none"> Black Hot Red Hot Red Monochrome Rainbow Ultramarine Violet Sepia
<ul style="list-style-type: none"> Manual/Auto > PIP > 	<ul style="list-style-type: none"> M Manual SA Semi-Automatic A Automatic
<ul style="list-style-type: none"> Wi-Fi > 	<ul style="list-style-type: none"> PAS 12345 Owner Guest

Tab 2

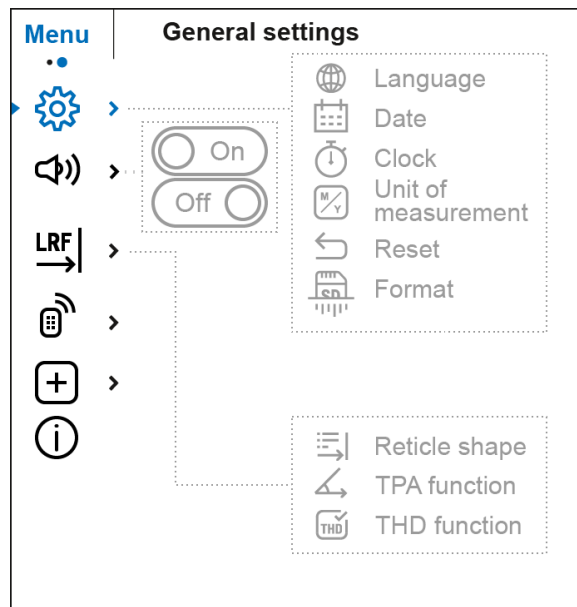

Remote control

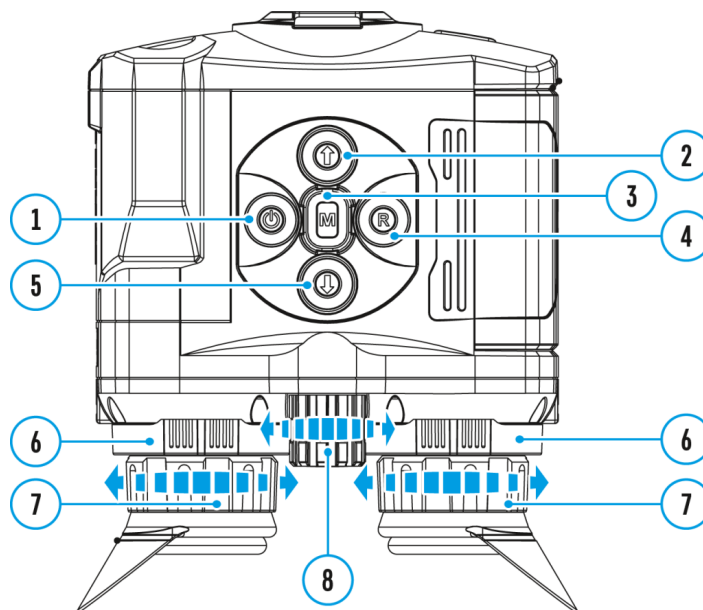

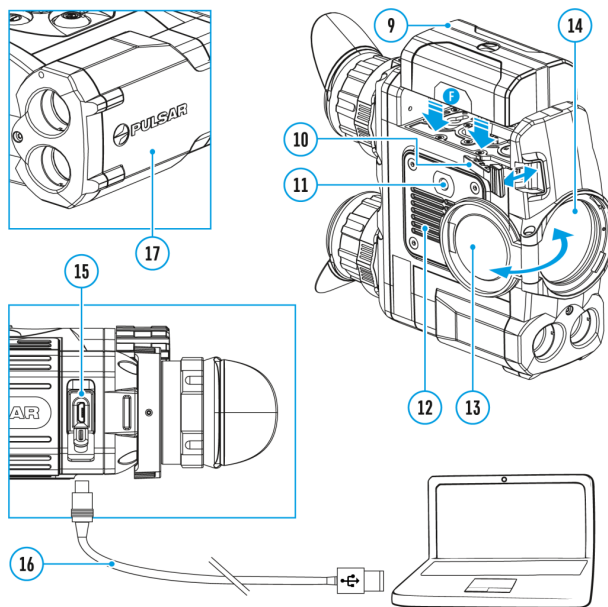

This feature is not supported on devices manufactured after August 1, 2021.

Remote control activation (bought separately)

Before operating the remote control (**RC**), remember to activate it as follows:

1. Press and hold down the **Menu (3)** button to enter the main menu.
2. Select option **Remote Control**



with the **UP (2)/DOWN (5)** buttons.

3. Press briefly the **Menu (3)** button to confirm.
4. Display shows message **"Wait"** and countdown starts (30 sec), within which hold down for two seconds any **RC** button.
5. If activation is successful, the message **"Connection complete"** appears



6. If error occurs the message **"Connection failed"** appears



. Repeat the procedure.

7. The **RC** is activated and ready for use.

8. To unlink the **RC**, press the **Menu (3)** button, wait for the countdown to expire without pressing any **RC** button for 30 sec.
9. All remote controls previously linked to your device are now unlinked.
10. Now you can activate your **RC** again or activate another **RC**.

Rangefinder

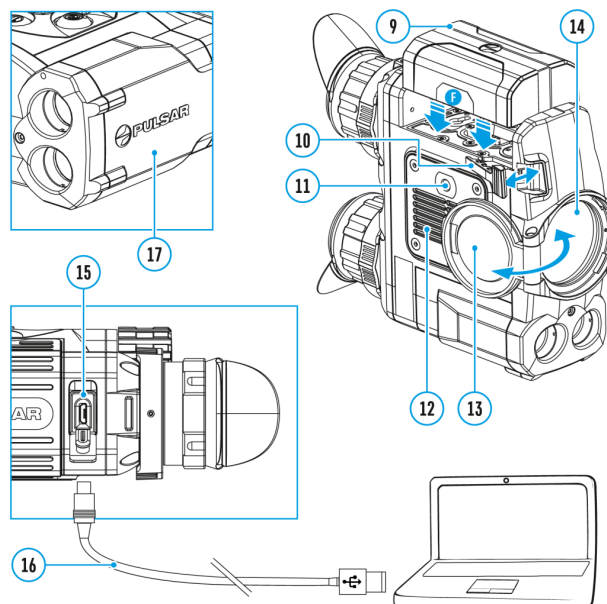
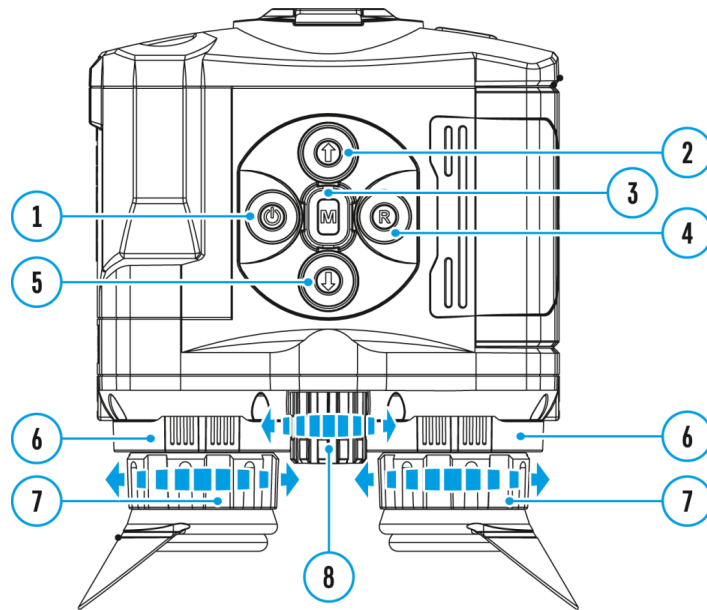

Menu item **Rangefinder** allows you to set up built-in rangefinder's parameters as follows:

1. Enter the main menu with a long press of the **Menu (3)** button.
2. Select the submenu **Rangefinder**



with the **UP (2)/DOWN (5)** buttons.

3. Enter the submenu with a short press of the **Menu (3)** button.
4. Select the desired menu item with the **UP (2)/DOWN (5)** buttons.

Reticle Type

1. Select the **Reticle Type**



menu item with the **UP (2)/DOWN (5)** buttons.

2. Press briefly the **Menu (3)** button to enter submenu.
3. Select one of the three reticle shapes

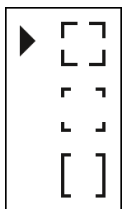

with the **UP (2)/DOWN (5)** buttons.

4. Confirm selection with a brief press of the **Menu (3)** button.
5. Selected reticle will appear on the display.
6. The reticle will disappear from the display if the rangefinder is not used longer than 4 seconds.

TPA

Function "TPA" (Target Position Angle) allows you to measure the angle of target location (angle of elevation). When the function is activated, the angle is shown continuously.

1. Select **TPA**



with the **UP (2)/DOWN (5)** buttons.

2. Turn **TPA** on/off with a short press of the **Menu (3)** button.

THD

"THD" (True Horizontal Distance) function allows you to measure true horizontal distance to a target based on the angle of elevation value.

1. Select **THD**



with the **UP (2)/DOWN (5)** buttons.

2. Turn **THD** on/off with a short press of the **Menu (3)** button
3. Hereinafter the message **THD** will appear above the distance readings.

Microphone

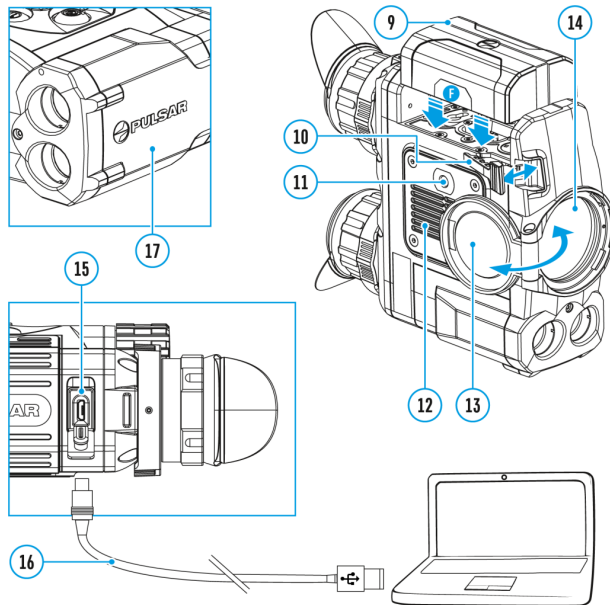
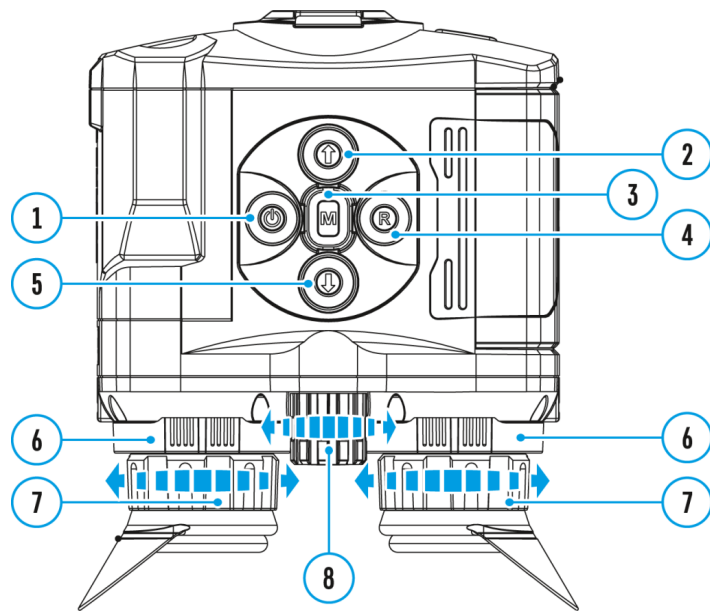

Turning on/off Microphone

This item allows you to enable (or disable) the microphone for recording sound during video recording.

1. Press and hold the **Menu (3)** to enter the main menu.
2. Select the **Microphone**



menu item with the **UP (2)/DOWN (5)** buttons.

3. To turn on the microphone, briefly press the **Menu (3)** button.



4. To turn off the microphone, briefly press the **Menu (3)** button.



Functions

Display-off function

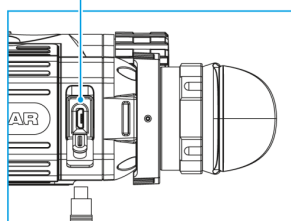
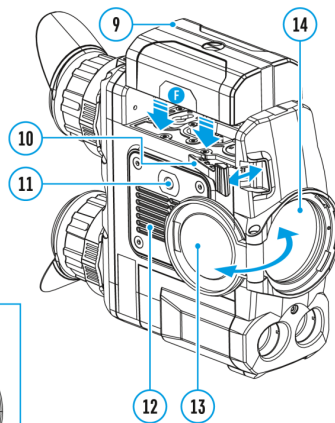
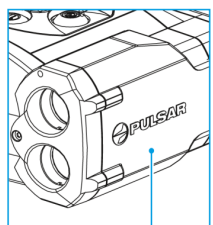
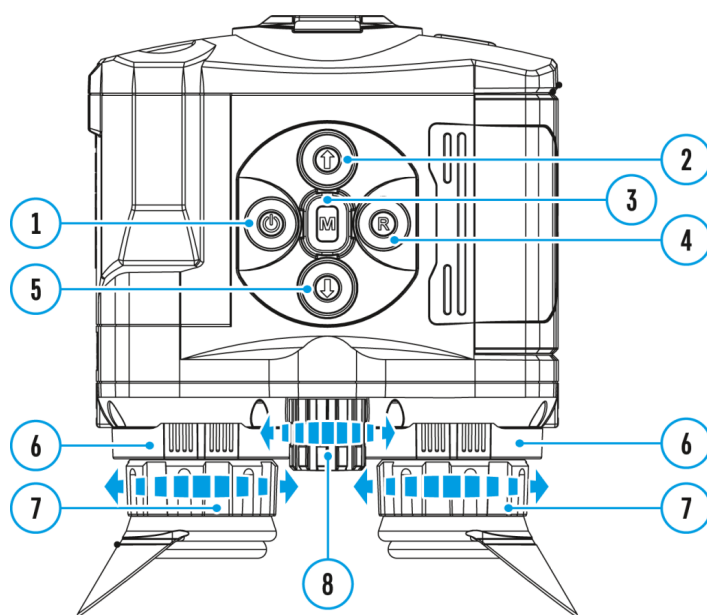

The Display-Off function deactivates transmission of image to the display by minimizing its brightness. This prevents accidental disclosure. The device keeps running.

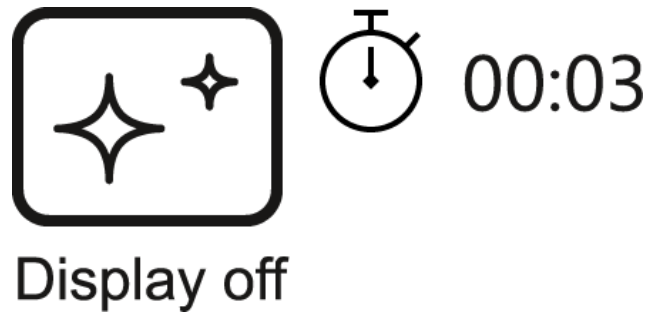

1. When the device is on, hold down the **ON/OFF (1)** button. Display goes out, message **"Display off"** appears.
2. To activate the display, press briefly the **ON/OFF (1)** button.
3. When you press and hold the **ON/OFF (1)** button, the display shows the message **"Display off"** with a countdown. Pressing & holding the button down for the duration of the countdown will power the device off completely.

Built-in laser rangefinder

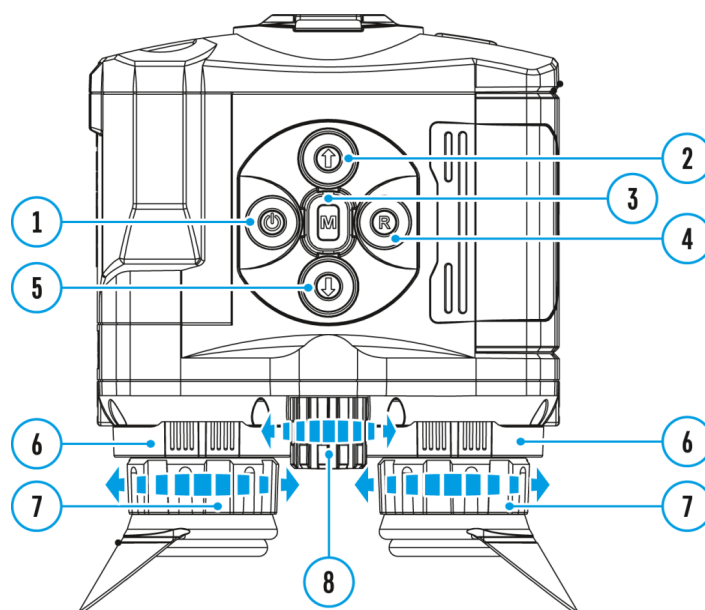

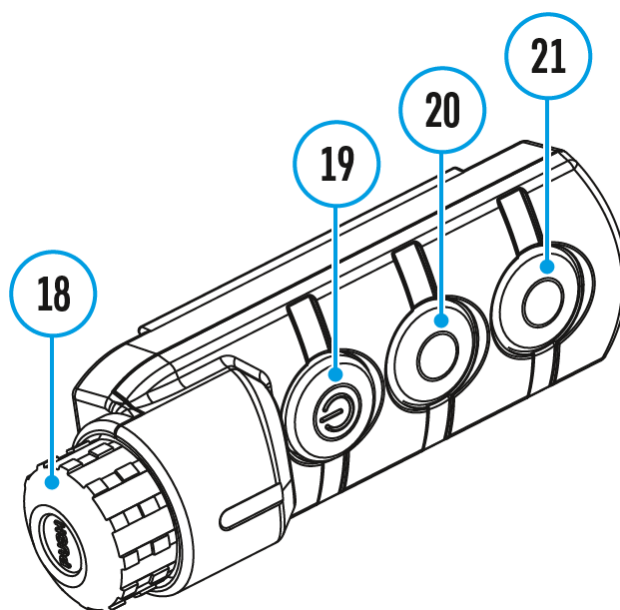
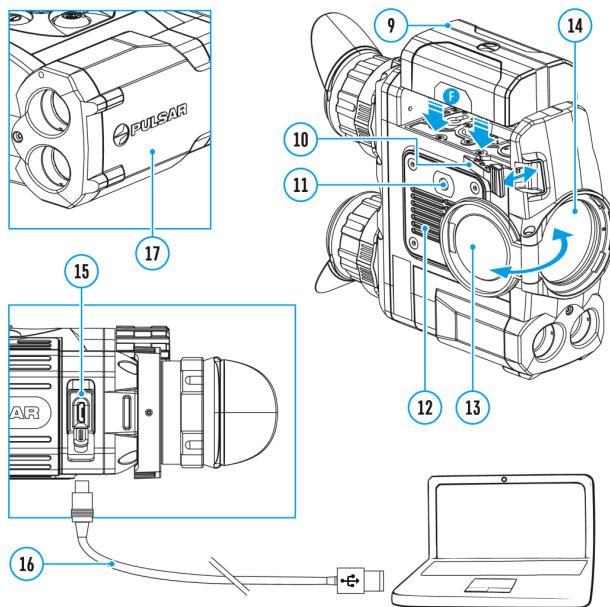

The binoculars are equipped with a built-in rangefinder **(17)**, allowing you to measure distance to objects up to 1000m away.

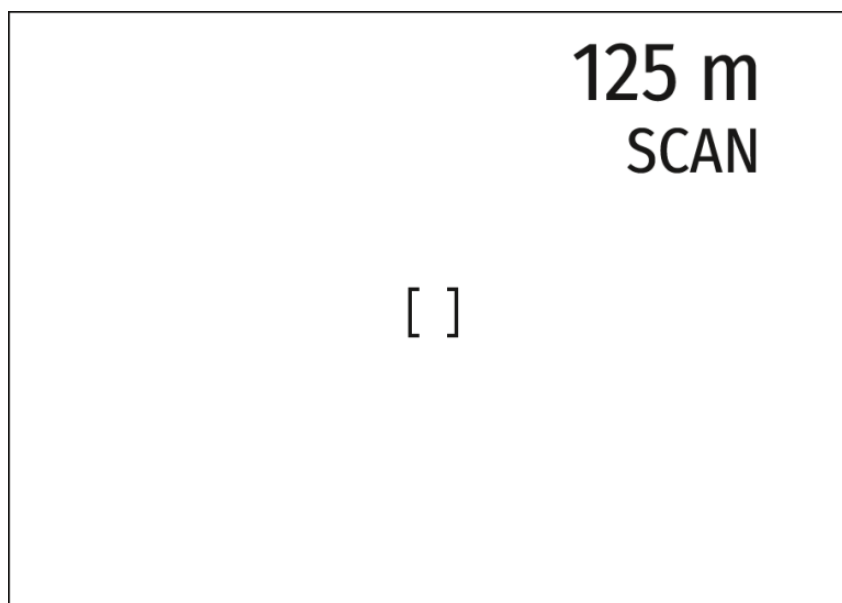

How the rangefinder works:

1. Turn on the device, set up image according to section **Powering On and Image Setting**.
2. Press the **UP (2)** or **LRF (21)** button on remote control – rangefinding reticle appears; in the top right corner of the display dashes of distance values with unit of measurement appear, i.e. the rangefinder enters the stand-by mode.



----m

3. If PiP mode is activated, the PiP window remains active upon activation of the rangefinder.
4. Point the rangefinding reticle at an object and press the **UP (2)** button.
5. In the top right corner of the display you will see distance in meters (or yards – depending on settings).

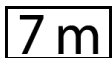

7m

Note: if the rangefinder is idle longer than for 4 seconds, it turns off automatically.

Operation in SCAN mode:

1. To measure distance in scanning mode, hold down the **UP (2)** or **LRF (21)** button on remote control for longer than two seconds. Measurement readings will be changing in real time as you point the binoculars at different objects. Message **SCAN** appears in the top right corner.
2. To exit **SCAN** mode, press **UP (2)** or **LRF (21)** button again.
3. If measurement fails, dashes will appear on the display.
4. In 4 seconds of inactivity (no measurement is taken) the rangefinder turns off, the rangefinding reticle with readings disappears from the display.

Notes:

- To select a rangefinding reticle, please see the **Reticle Type** subsection in the **Rangefinder** section.
- To select a unit of measurement (meters or yards) go to the **Units of Measure** subsection of the **General Settings** section.

Additional Information:

- Accuracy of measurement and maximum range depend on the reflection ratio of the target surface, the angle at which the emitting beam falls on the target surface and environmental conditions. Reflectivity is also affected by surface texture, color, size and shape of the target. A shiny or brightly colored surface is normally more reflective than a dark surface.
- Measuring range to a small sized target is more difficult than to a large sized target.
- Accuracy of measurement can also be affected by light conditions, fog, haze, rain, snow etc. Ranging performance can degrade in bright conditions or when ranging towards the sun.

Wi-fi function

The device has a function enabling wireless communication with external devices (smartphone or tablet) via Wi-Fi.

- Turn on the wireless module in the **WI-Fi Activation**



menu option.

Wi-Fi operation is shown in the status bar as follows:

Connection status

Status bar indication

Wi-Fi is off



Wi-Fi activated by the user,

Wi-Fi in the device is being activated



Wi-Fi is on, no connection with device



Wi-Fi is on, device connected



- Your device is detected by an external device as "Accolade 2 LRF_XXXX", where XXXX – is the last four digits of device's serial number.
- After entering the password (default: **12345678**) on an external appliance (see **Password Setup** subsection of the **Wi-Fi Settings** section for more information on setting a password) and connection is established, the icon



in the status bar changes to



- When Wi-Fi is on, the power supply will switch to the internal battery after the external battery reaches a 20% charge level.

Video recording and photography

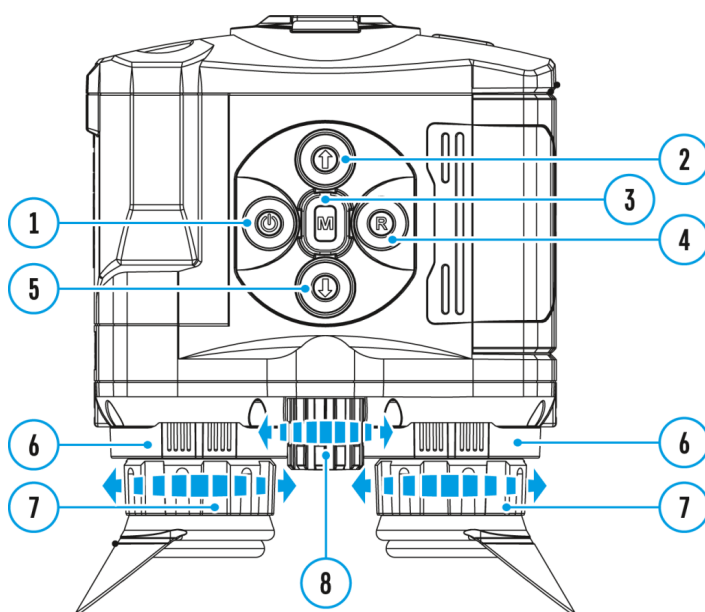

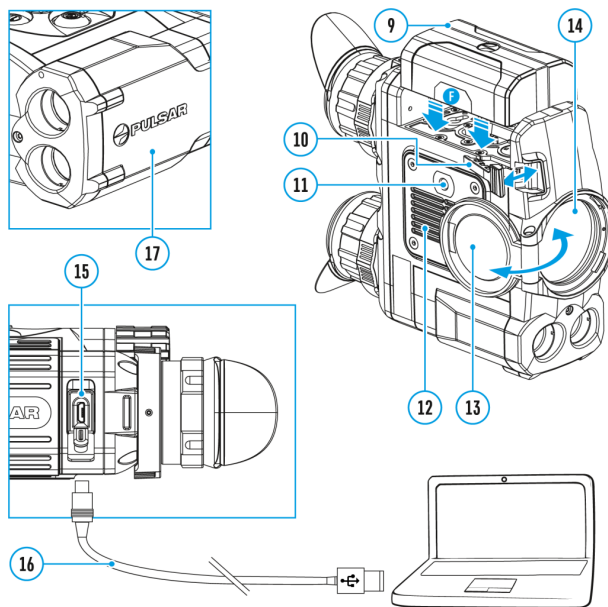

Accolade 2 LRF Pro thermal imaging binoculars feature video recording and photography of the image being ranged to the internal memory card.

Before using this feature, please read the **Date** and **Time** subsections of the section **General Settings**.

The built-in recorder operates in two modes – **Video** and **Photo**.

Video mode. Video recording



1. Switch to **Video** mode by pressing and holding the **REC (4)** button.
2. In the top left corner you will see icon



and remaining recording time in the format HH:MM (hours: minutes).

3. Start video recording with a short press of the **REC (4)** button.
4. Upon start of video recording icon



disappears, and icon REC and recording timer in the format MM:SS (minutes : seconds) appear instead:

5. Pause and resume recording video with a short press of the **REC (4)** button.
6. Stop recording video with a long press of the **REC (4)** button.
7. Video files are saved to the memory card after stopping video.
8. Switch between modes (**Video**→ **Photo**→ **Video**) with a long press of the **REC (4)** button.

Photo mode. Capturing an image



1. Switch to the **Photo** mode with a long press of the **REC (4)** button.
2. Take a picture with a brief press of the **REC (4)** button. The image freezes for 0.5 sec and a photo is saved to the internal memory.
3. In the top left corner of the display you can see: photography icon



, ">100" means that you can take more than 100 pictures. If the number of available pictures is less than 100, actual amount of available pictures (for example 98) is shown next to the icon



Notes:

- You can enter and operate the menu during video recording.
- Recorded videos and photos are saved to the built-in memory card in the format img_xxx.jpg (photos); video_xxx.avi (videos). xxx – three digit counter for videos and photos.
- Counter for multimedia files cannot be reset.

Attention!

- The maximum duration of a recorded file is five minutes. After this time expires, a video is recorded into a new file. The number of recorded files is limited by the capacity of the device's internal memory.
- Check regularly the free capacity of the internal memory, move recorded footage to other storage media to free up space on the internal memory card.
- When the Display Off function is activated, video recording is paused.

Important!

To playback video files recorded by thermal imaging devices on macOS based computers, we recommend that you use VLC video player or Elmedia player.

Download links are shown below:

VLC Video Player

<http://www.videolan.org/vlc/download-macosx.html>

ELMEDIA Video Player

<https://apps.apple.com/us/app/elmedia-multiformat-video/id937759555?mt=12>

Software

Wireless remote control

This feature is not supported on devices manufactured after August 1, 2021.

(Bought separately)

Wireless remote control **(RC)** duplicates the power on function, digital zoom, rangefinder control, and menu navigation.

	Controller (18)	Button ON (19)	Button ZOOM (20)	Button LRF (21)
Brief press	Enter the quick menu	Turn on the device / Calibrate the microbolometer	Activate incremental zoom	Activate rangefinder / Measure distance
Long press	Enter the main menu	Display Off / Turn off the device	Activate function PiP	Activate SCAN mode
Clockwise rotation	Increase parameter, move upwards			
Counterclockwise rotation	Decrease parameter, move downwards			

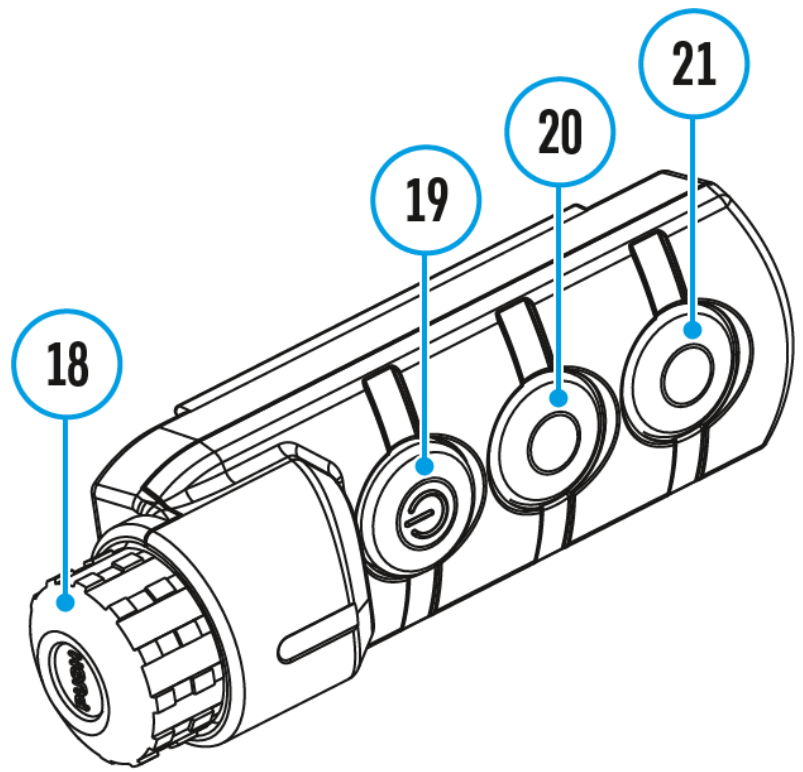

USB connection

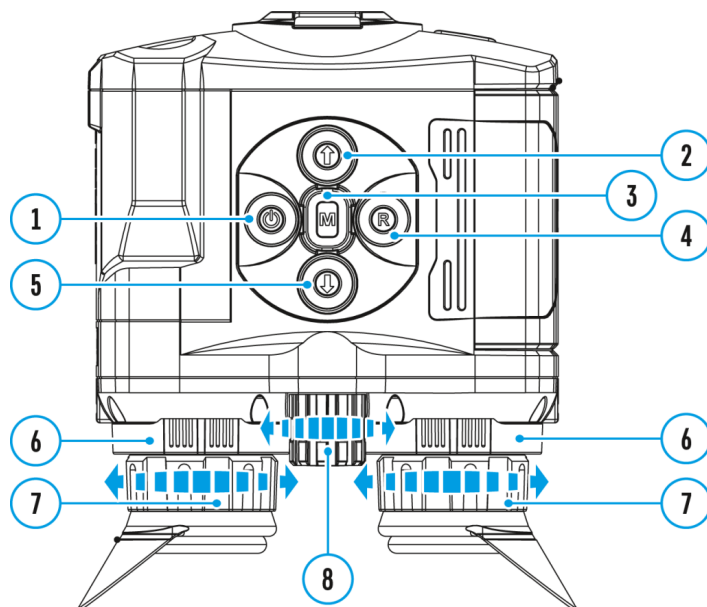

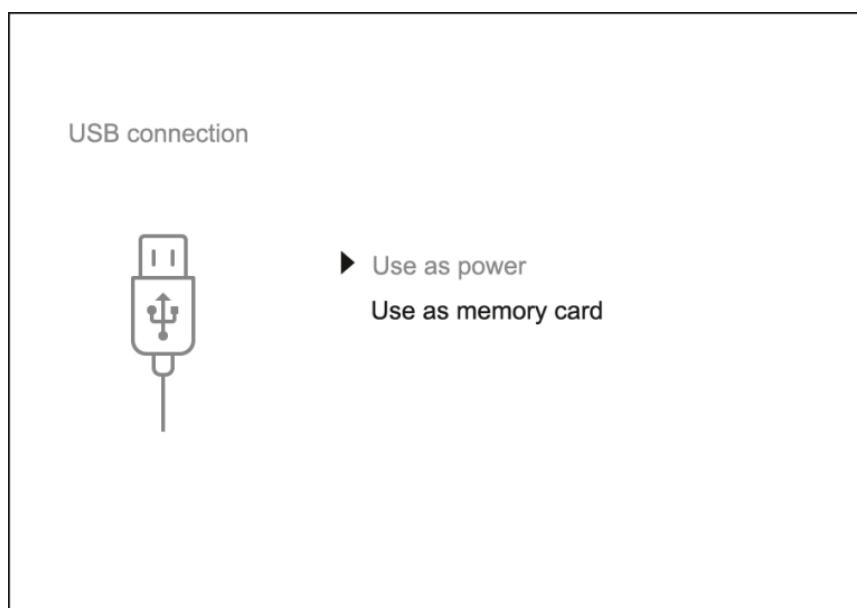
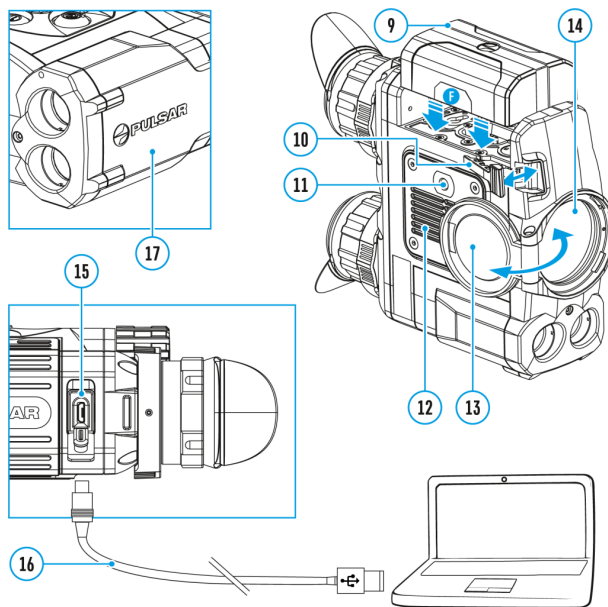

1. Connect one end of the USB cable **(16)** to the Micro-USB **(15)** port of your device, and the other end to the USB port of your PC/laptop.
2. Turn the device on with a short press of the **ON/OFF (1)** button (device that has been turned off cannot be detected by your computer).
3. Your device will be detected by the computer automatically; no drivers need to be installed.
4. Two connection modes will appear on the display: **Power** and **Memory Card** (external memory).
5. Select connection mode with **UP (2)/DOWN (5)** buttons.
6. Confirm selection with a short press of the **Menu (3)** button.

Connection modes:

Power

- In this mode, when a computer is used as an external power supply, the icon



appears in the status bar. The device will continue operating and all functions are available.

- The Battery pack installed in the device is not being charged!
- When disconnecting from the computer, the device will continue to operate from the battery pack (if it is present and holding enough charge).

Memory Card (external memory)

- In this mode the device is detected by the computer as a flash card. This mode is designed for work with the files saved in device's memory. The device's functions are not available in this mode; the device turns off automatically.
- If video recording was in progress when connection was made, recording stops and video is saved.
- When USB is disconnected from the device where connection is in the **Memory Card** mode, the device remains on the OFF state. Turn the device on for further operation.

Firmware update

Stream Vision

1. Download free of charge Stream Vision App on **Google Play** or **App Store**.
2. Connect your Pulsar device to your mobile device (smartphone or tablet).
3. Launch Stream Vision and go to section "My Devices".
4. Select your Pulsar device and press "Check Updates".
5. Wait for the update to download and install. Pulsar device will reboot and will be ready to operate.

Important:

- if your Pulsar device is connected to phone, please turn on mobile data transfer (GPRS/3G/4G) to download update;

- if your Pulsar device is not connected to your phone but it's already in the "My Devices" section, you may use Wi-Fi to download update.

Find answers to frequently asked questions about using Stream Vision [here](#).

Is your firmware up to date?

Click [here](#) to check the latest firmware for your device.

Stream Vision 2

1. Download free Stream Vision 2 App in [Google Play](#) or [App Store](#).
2. Connect your Pulsar device to your mobile device (smartphone or tablet).
3. Launch Stream Vision 2 and go to section "Settings".
4. Select your Pulsar device and press "Check firmware update".
5. Wait for the update to download and install. Pulsar device will reboot and will be ready to operate.

Important:

- if your Pulsar device is connected to phone, please turn on mobile data transfer (GPRS/3G/4G) to download update;
- if your Pulsar device is not connected to your phone but is already listed in "Settings" > "My devices" section, you may use Wi-Fi to download update.

Find answers to frequently asked questions about using Stream Vision 2 [here](#).

Stream vision

STREAM VISION



Accolade 2 LRF Pro thermal imaging binoculars support Stream Vision technology which allows you to stream an image from the display of your thermal imager to a smartphone or tablet PC via Wi-Fi in real time mode.

You can find further guidelines on Stream Vision [here](#).

[Download from Google Play](#)

[Download from App Store](#)

Find answers to frequently asked questions about using Stream Vision [here](#).

Maintenance

Technical maintenance and storage

Maintenance should be carried out no less frequently than twice a year, and should consist of the following measures:

- Wipe the exterior surfaces of metal and plastic parts off dust and dirt with a cotton cloth. To avoid damage to the paint coating, do not use chemically active substances, solvents, etc.
- Clean the electric terminals of the Battery Pack and device's battery slot using a grease-free organic solvent.
- Check the objective and eyepieces lenses; rangefinder's emitter and receiver lenses. If required, remove dust and sand (preferably by a noncontact method). Clean the external surfaces of the lenses with products expressly designed for this purpose.
- Always store the device in its carrying case in a dry, well-ventilated space. Remove the Battery Pack for long-term storage.

Technical inspection

It is recommended to carry out a technical inspection before each use of the device. Check the following:

- External view (there should be no cracks on the housing).
- The state of the objective, eyepiece and rangefinder lenses (there should be no cracks, spot, dust, deposits etc.).

- The state of the rechargeable battery (should be charged) and the electric contacts (should be no signs of salts, oxidation or debris).
- Correct functioning of the controls.

Troubleshooting

Support

For technical support please contact support@pulsar-vision.com.

Answers to frequently asked questions about the devices can also be found in the **FAQ** section.

Legal compliances and disclaimers

Attention! Accolade 2 LRF Pro thermal imaging binoculars require a license if exported outside your country.

Electromagnetic Compliance

This product complies with EU Standard EN 55032:2015, Class A.

Warning! Operation of this equipment in a residential environment could cause radio interference.



Caution – use of controls or adjustments or performance of procedures other than those specified herein may result in hazardous radiation exposure.

Updates of the Product. The manufacturer reserves the right at any time, without mandatory prior notice to the Customer, to make changes to the package contents (subject to the applicable laws, if any), design and characteristics that do not impair the quality of the Product.

Repair. Repair of the product is available within 5 years after purchase of the product.

Limitation of Liability. Subject to mandatory applicable laws and regulations: manufacturer will not be liable for any claims, actions, suits, proceedings, costs, expenses, damages or liabilities (if any), arising out of the use of this product. Operation and use of the product are the sole responsibility of the Customer. Manufacturer's sole undertaking is limited to providing the product(s) and related services in accordance with the terms and conditions of concluded transactions, including provisions established in warranty. The provision of products sold and services performed by Manufacturer to the Customer shall not be interpreted, construed, or regarded, either expressly or implied, as being for the benefit of or creating any obligation toward any third party (other than Distributor, Dealer, Buyer). Manufacturer's liability hereunder for damages, regardless of the form or action, shall not exceed the fees or other charges paid to Manufacturer for the product(s) and/or service(s).

MANUFACTURER WILL NOT BE LIABLE FOR LOST REVENUES OR INDIRECT, SPECIAL, INCIDENTAL, CONSEQUENTIAL, EXEMPLARY, OR PUNITIVE DAMAGES, EVEN IF THE MANUFACTURER KNEW OR SHOULD HAVE KNOWN THAT SUCH DAMAGES WERE POSSIBLE AND EVEN IF DIRECT DAMAGES DO NOT SATISFY A REMEDY.

EAC

C E

