

# PULSAR AXION 2 Manual

## **Specifications**

### **About the device**

Features

Description

### **Power supply**

Recommendations for Use

Precautions

External Power Supply

Battery Installation

Battery Charging

Components and Controls

### **Getting started**

Button Operation

Powering on and Image Settings

### **Interface**

Quick Menu

Status Bar

### **Functions**

USB Connection

Installing the Device on a Tripod

Stadiametric Rangefinder

Wi-Fi Function

Display-Off Function

PiP Function

Discrete Digital Zoom

Video Recording and Photography

Amplification Level

### **Software**

Firmware Update

Stream vision 2

### **Maintenance**

Technical Maintenance and Storage

Technical Inspection

### **Troubleshooting**

### **Package Contents**

### **Legal Compliances and Disclaimers**

# Specifications

<b>Model</b>	<b>XQ35</b>
SKU	77478
<b>Microbolometer</b>	
Type	uncooled
Resolution, Pixels	384×288
Pixel Pitch, $\mu\text{m}$	17
Frame Rate, Hz	50
<b>Optical Characteristics</b>	
Optical Magnification, x	2
Smooth Digital Zoom, x	2-8
Digital Zoom, x	x1, x2, x4
Lens Focus, mm	35
Relative Aperture, D/f'	1.0
Minimum Focus Distance, m/y	5 / 5.47
Eye Relief Diameter, mm/inch	4 / 0.16
Angular Field of View (Horizontal x Vertical), degree	10.7x8
Linear Field of View, m at 100 m	18.2
Eyepiece Focus Range, Diopter	+4 / -5
Detection Distance for DeerSized Objects, m/y	1300 / 1422
<b>Display</b>	
Type	AMOLED

Resolution, Pixels	640×400
<b>Operational Characteristics</b>	
Power Supply, V	3 – 4.2
Battery Type/Capacity/Nominal Output Voltage	APS 5 Li-ion Battery Pack / 4900 mAh / DC 3.7 V
External Power Supply	5 V, 9 V (USB Type-C)
Battery Run Time at t=22°C, hours*	11
Degree of Protection, IP Code (IEC60529)	IPX7
Operating Temperature Range, °C / °F	-25 ... +40 / -13 – +104
Dimensions, mm/inch	152×50×74 / 5.98×1.97×2.91
Weight (without battery), kg/oz	0.3 / 10.58
<b>Video Recorder</b>	
Photo/Video Resolution, Pixels	528×400
Video/Photo Format	.mp4 / .jpg
Built-in Memory	16 GB
<b>Wi-Fi Channel**</b>	
Frequency	2.4/5 GHz
Standard	IEEE 802.11 b/g/n/ac

\*Actual battery life may vary depending on the use of Wi-Fi and the built-in video recorder.

\*\* Reception range may vary depending on various factors: obstacles, other Wi-Fi networks.

---

## About the device

# Features

- Compact and lightweight
- Functional and ergonomic design
- 8-color display palette
- 3 calibration modes: Manual, Semi-Automatic, Automatic
- Three levels of sensitivity enhancement: Normal, High, Ultra
- Stadiametric Rangefinder
- Display-Off function
- Defective pixel repair
- Updatable firmware
- Wide operating temperature range (-25°C to +40°C / -13°F to +104°F)
- Fully waterproof (IPX7 rated)
- Tripod mount

# Description

**Axion 2** thermal imaging monoculars are designed for use both at nighttime and during the day and provide exceptional image quality even in adverse weather conditions (fog, smog, rain) and beyond obstacles like branches, tall grass, dense foliage, etc. known to hinder target detection.

Unlike night-vision devices based on electron-optical converters, thermal imaging devices do not need an external light source and are resistant to bright light.

**Axion 2** thermal imagers are designed for various applications including hunting, observation, security, terrain orientation, search and rescue operations, etc.

---

# Power supply

## Recommendations for Use

- The batteries should be partially charged (50 to 80 %) for long-term storage.
- Charge at an ambient temperature of 0°C to +35°C (32°F to 95°F) or the lifespan of the battery will decrease significantly.
- Using the battery at sub 0°C (<32°F) ambient temperature decreases battery capacity. This is normal and not a defect.
- Using the battery at temperatures outside the range of -25°C to +40°C (- 13°F to 104°F) may reduce battery life.
- The battery is short-circuit protected. Any situation that may cause short-circuiting should be avoided.

## Precautions

- Always use the APS 5 charger (purchased separately) to charge APS 5 batteries. Using an unsuitable charger can cause irreparable damage to the battery and fire.
- Do not charge the battery immediately after exposure to a cold environment. Let the battery warm for at least 30 minutes before charging.
- Do not leave the battery unattended while charging.
- Do not use the charger if it has been modified or damaged.
- Do not leave the battery in a plugged-in charger after charging is complete.

- Do not expose the battery to high temperatures or open flames.
- Do not use the battery as a power source for devices that do not support APS 5 batteries.
- Do not disassemble or deform the battery or charger.
- Do not drop or strike the battery or charger.
- Protect the battery and charger from water and moisture.
- Keep the battery out of the reach of children.

## External Power Supply

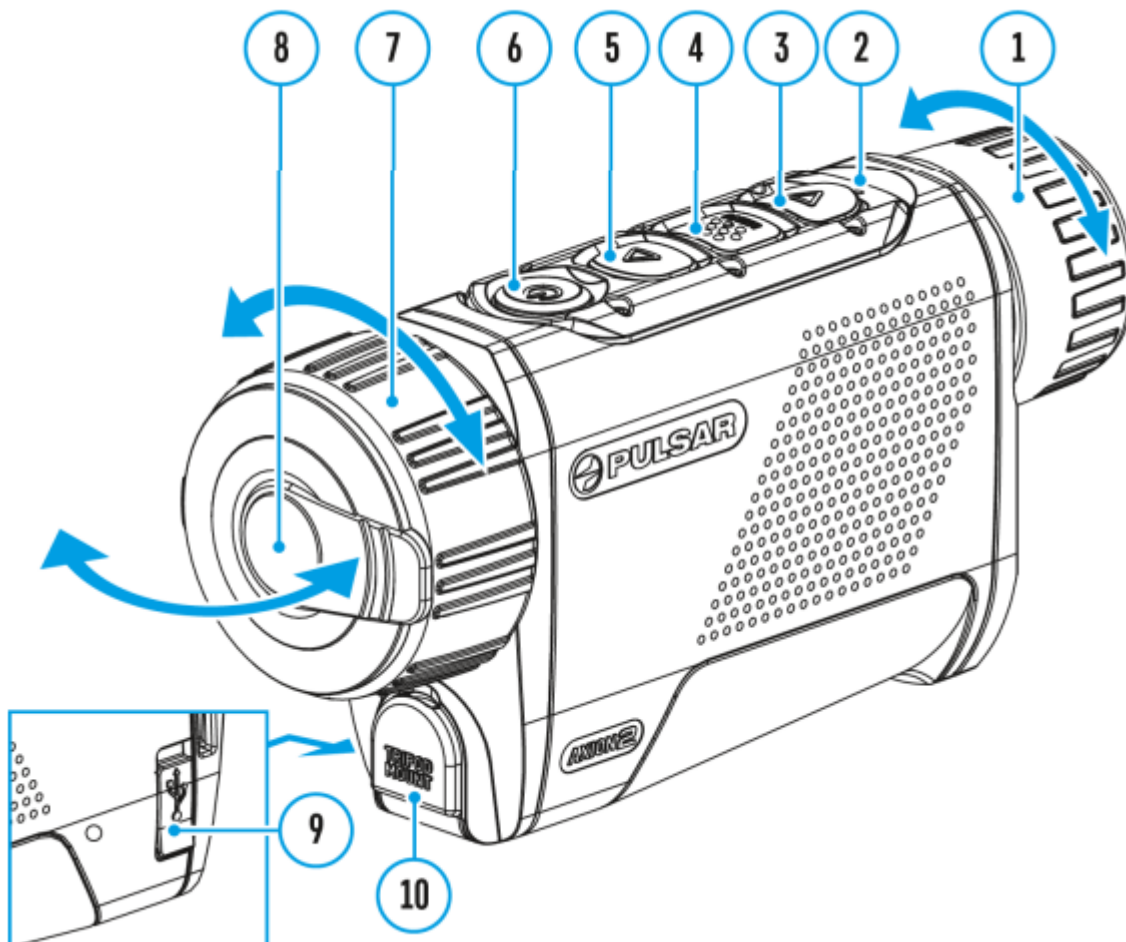

External power can be supplied from an external source, such as a Power Bank (5 V, 9 V).

1. Connect the external power source to the USB Type-C connector (9) on the device.

2. The device will switch to draw power from the external source while the APS5 battery is gradually recharged.
3. A battery icon



will appear on the display showing the percentage charged level.

4. An icon



will be displayed when the device is powered by an external power source and the APS5 battery is not connected.

5. The device automatically switches to the APS 5 battery when the external power supply is disconnected.

**Attention!** Charging APS 5 batteries from an external source at temperatures below 0°C (<32°F) can reduce battery life. When using external power, connect the power bank to the device only after it has been turned on and working (warming) for at least several minutes.

## Battery Installation

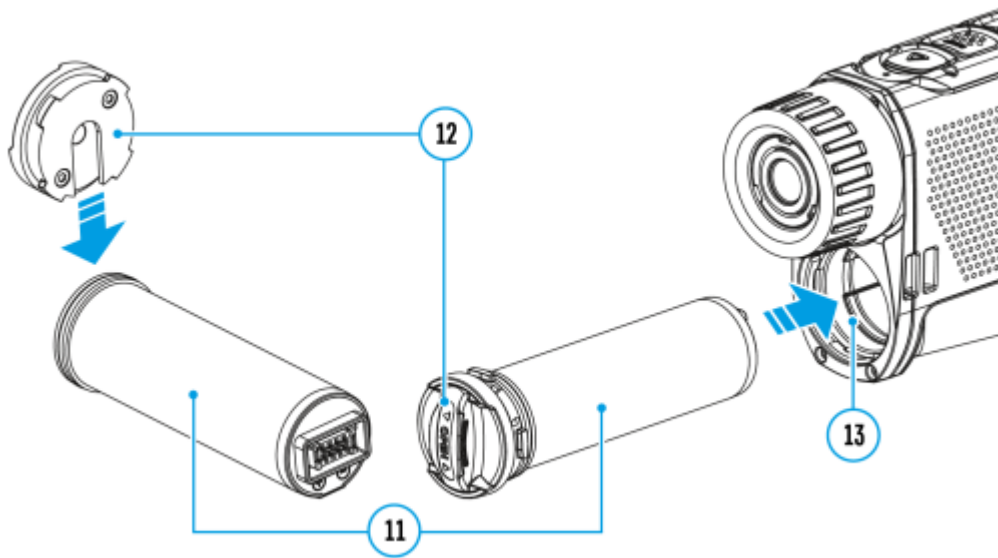

1. Put the Lock-cover **(12)** on the rechargeable APS 5 battery **(11)**.
2. Insert the APS 5 battery **(11)** along the guide into the battery compartment **(13)**.
3. Lock the battery **(11)** by turning the Lock-cover **(12)** clockwise until it stops.
4. Turn the Lock-cover **(12)** counter-clockwise to remove the battery **(11)**.

## Battery Charging

The **Axion 2** thermal imager comes with an APS 5 rechargeable Lithium-ion battery. APS 5 batteries support USB Power Delivery fast charging technology when using a standard charging set (charger\*, USB Type-C cable, power adapter). Before first use, make sure the battery is fully charged.

### Option 1



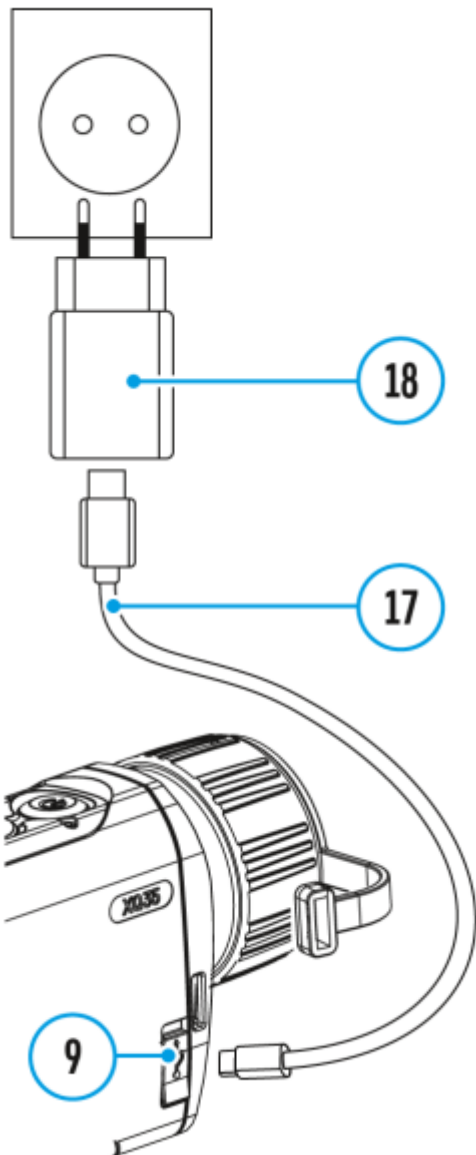
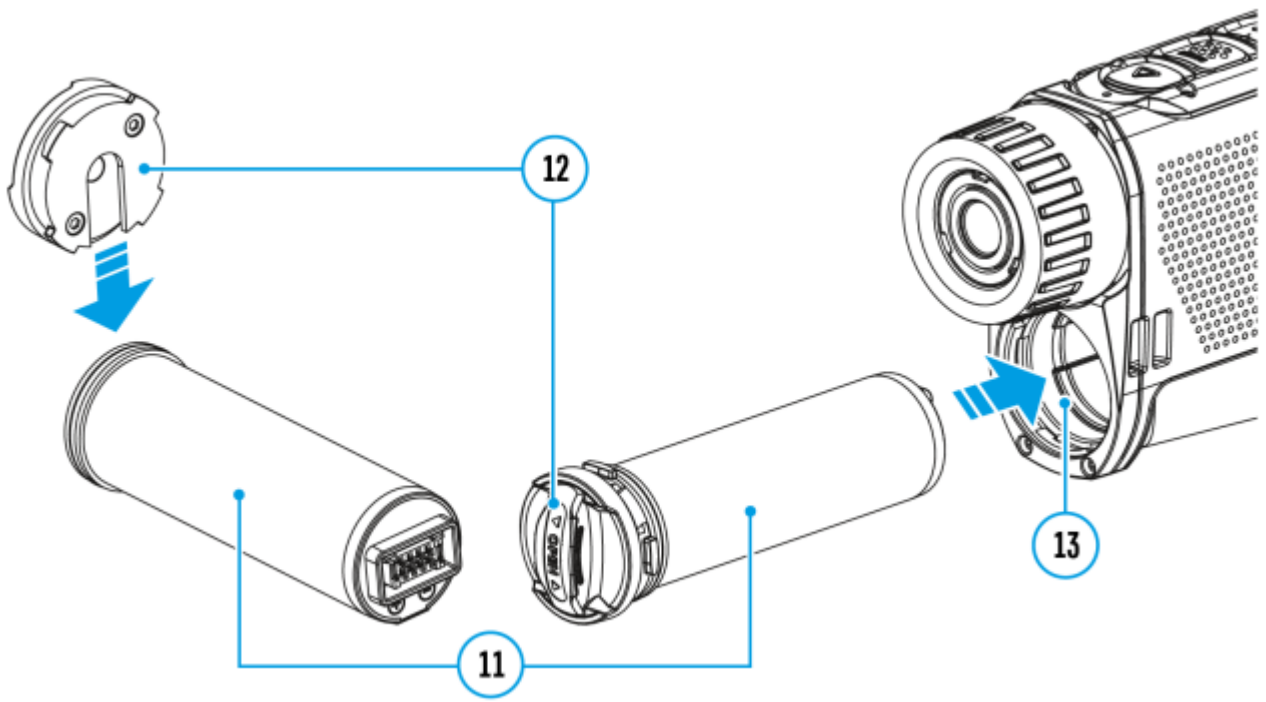

1. Install the APS 5 battery **(11)** in the battery compartment **(13)** of the device.
2. Connect the USB cable **(17)** to the USB Type-C connector **(9)** of the device.
3. Connect the other end of the USB cable **(17)** to the Power Adapter **(18)**.
4. Plug the Power Adapter **(18)** into a 100-240 V socket.
5. Wait until the battery is fully charged (indication in the status bar:



## Option 2

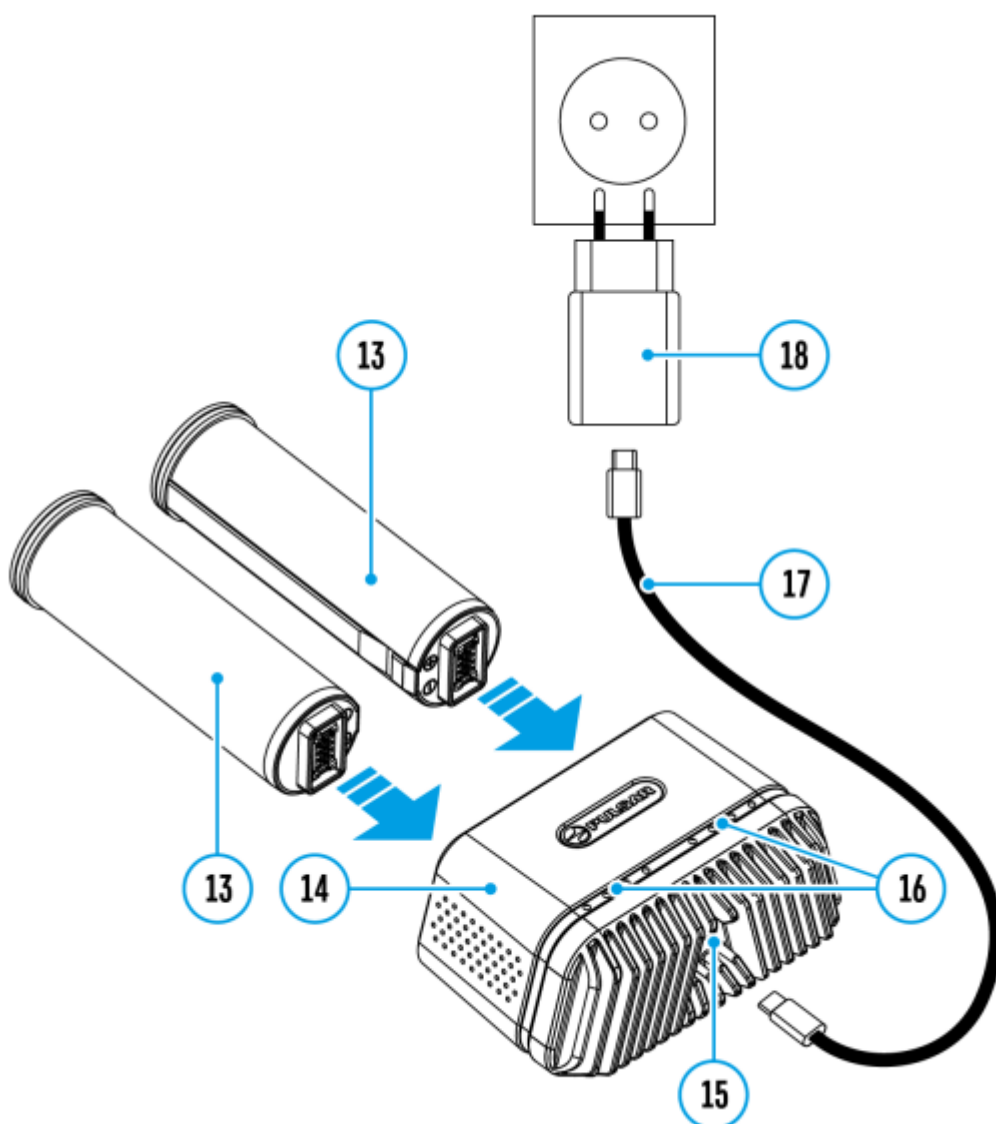

1. Insert the APS 5 battery **(13)** along the guide into the APS 5 charger\* **(15)** slot as far as it will go.
2. Connect the plug of the USB Type-C cable **(17)** to the USB Type-C connector of the Power Adapter**(18)**.
3. Plug the Power Adapter **(18)** into a 100-240 V socket.
4. Connect the other end of the USB Type-C cable **(17)** to the USB Type-C connector **(15)** of the charger.
5. LED indicators **(16)** will display the battery charge level (see Table).
6. Wait until the battery is fully charged (LED indication **(16)**):



**Note:** Two batteries can be charged at the same time, a second slot is provided for it.

**LED indication (16) in the battery charging mode**

**Battery Level**

•	Battery charge level is from 0% to 25%
• •	Battery charge level is from 26% to 50%
• • •	Battery charge level is from 51% to 80%
• •	Battery charge level is from 81% to 99%
• • • •	Battery is fully charged. Charging will automatically stop. The battery can be disconnected from the charger.
•	Defective battery. <b>Do not use the battery!</b>

**LED indication (16) in the standby**

**Battery Level**

## mode\*\*

•	Battery charge level is from 0% to 25%
•	Battery charge level is from 26% to 50%
••	Battery charge level is from 51% to 80%
• • •	Battery charge level is from 81% to 99%
•• ••	Battery is fully charged. It can be disconnected from the charger.
•	Defective battery. <b>Do not use the battery!</b>

\*Available separately

\*\* Standby mode is when the batteries are in the charger but the Power Adapter is not connected. In this mode, the indicators are only on for 10 seconds.

**Attention!** When using a Power Adapter that does not support USB Power Delivery fast charging technology, the flicker frequency of the LED indicators decreases by a factor of 3 and the charge time increases.

**Attention!** The charger heats up during fast charging. Excess heat is removed through the radiator and does not affect the device operation.

## Components and Controls

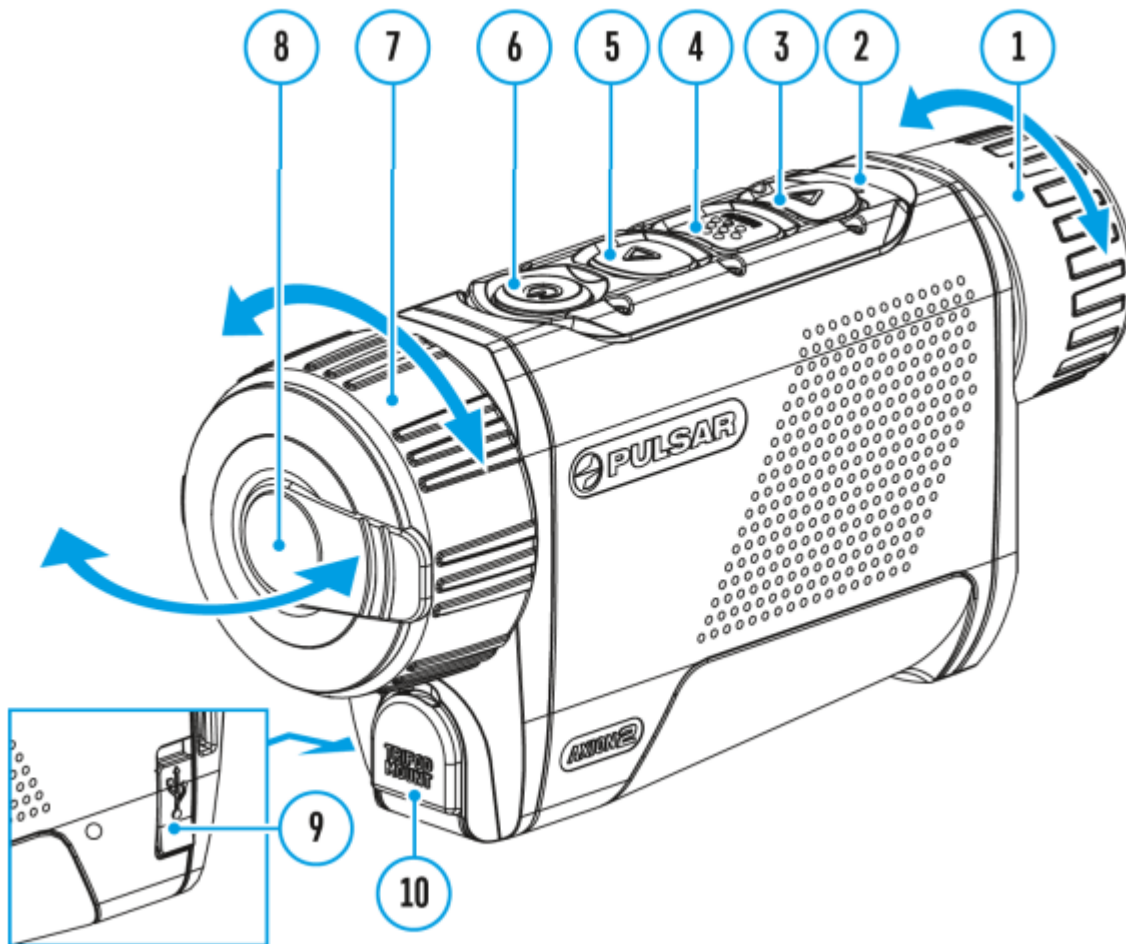

1. Eyepiece focus ring
2. LED indicator
3. DOWN/REC button
4. MENU button
5. UP/ZOOM button
6. Power ON/OFF/CALIBRATION button
7. Lens focus ring
8. Lens cover
9. Tripod adapter socket
10. USB Type-C connector

---

LED indicator (2) displays the current status of the device:







LED Indicator	Operating Mode
---------------	----------------

---

- Device is turned on
  - The device is turned on/video recording
  - The device is turned on/battery charge < 10%
  - The device is turned on/video recording/battery charge < 10%
- 

## Getting started

## Button Operation

Operation	Button
Power device on	 short press
Power device off	 long press for 3 secs
Turn display of	 long press for less than 3 secs
Turn display on	 short press
Calibrate the microbolometer	 short press
Switching amplification levels	 short press

Control discrete digital zoom



long press

---

## Video Recorder

## Button

---

Start/pause/resume video recording



short press

---

Stop video recording



long press

---

Switch to video / photo



long press

---

Capture a photo



short press

---

## Main Menu

## Button

---

Enter main menu



long press

---

Navigation upwards/rightwards



short press

---

Navigation downwards/leftwards



short press

---

Confirm selection



short press

---

Exit submenu without confirming selection



long press

---

Exit menu (switch to viewing mode)



long press

---

## Quick Menu

## Button

---

Enter quick menu



short press

---

Switch between quick menu options



short press

---

Increase value



short press

---

Decrease value



short press



## Powering on and Image Settings

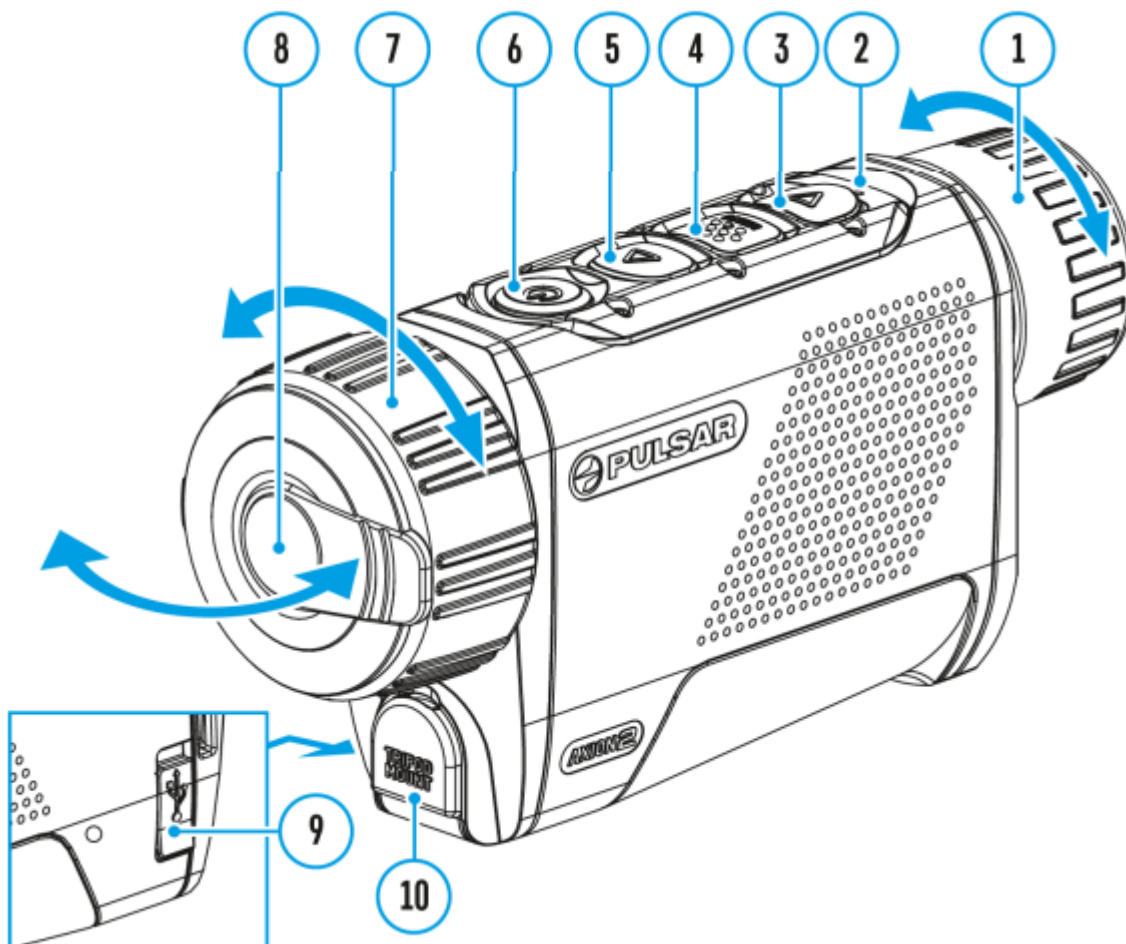

1. Open the lens cover **(8)**. The lens cover can be secured to the strap using the built-in magnet.
2. Press the **ON/OFF (6)** button briefly to turn on the device.
3. Adjust the eyepiece focus ring **(1)** of the device until the symbols on the display are sharp.
4. Rotate the lens focus ring **(7)** to focus on the object being observed.



5. Enter the main menu with a long press of the **MENU (4)** button and select the desired calibration mode: Manual (**M**), Semi-Automatic (**SA**) or Automatic (**A**).
6. Calibrate the image by briefly pressing the **ON/OFF (6)** button. If the **SA** or **A** calibration mode has been selected the microbolometer is closed with an internal shutter automatically. However, if the **M** calibration mode has been selected you must close the lens cover before calibrating manually.
7. Select the required amplification level ("**Normal**")



, "High"



, "Ultra"



) by briefly pressing the **UP (5)** button.

8. Enter the main menu with a long press of the **MENU (4)** button and select the desired color mode.
9. Activate the quick menu by briefly pressing the **MENU (4)** button to adjust the brightness, contrast and smooth digital zoom.
10. After use, turn the device off by a long press of the **ON/OFF (6)**

**Warning!** Never point the lens at intensive energy sources such as laser radiation emitting devices or the sun. It can damage electronic components in the device. The warranty does not cover damage arising from failure to comply with operating instructions.

---

## Interface

# Quick Menu

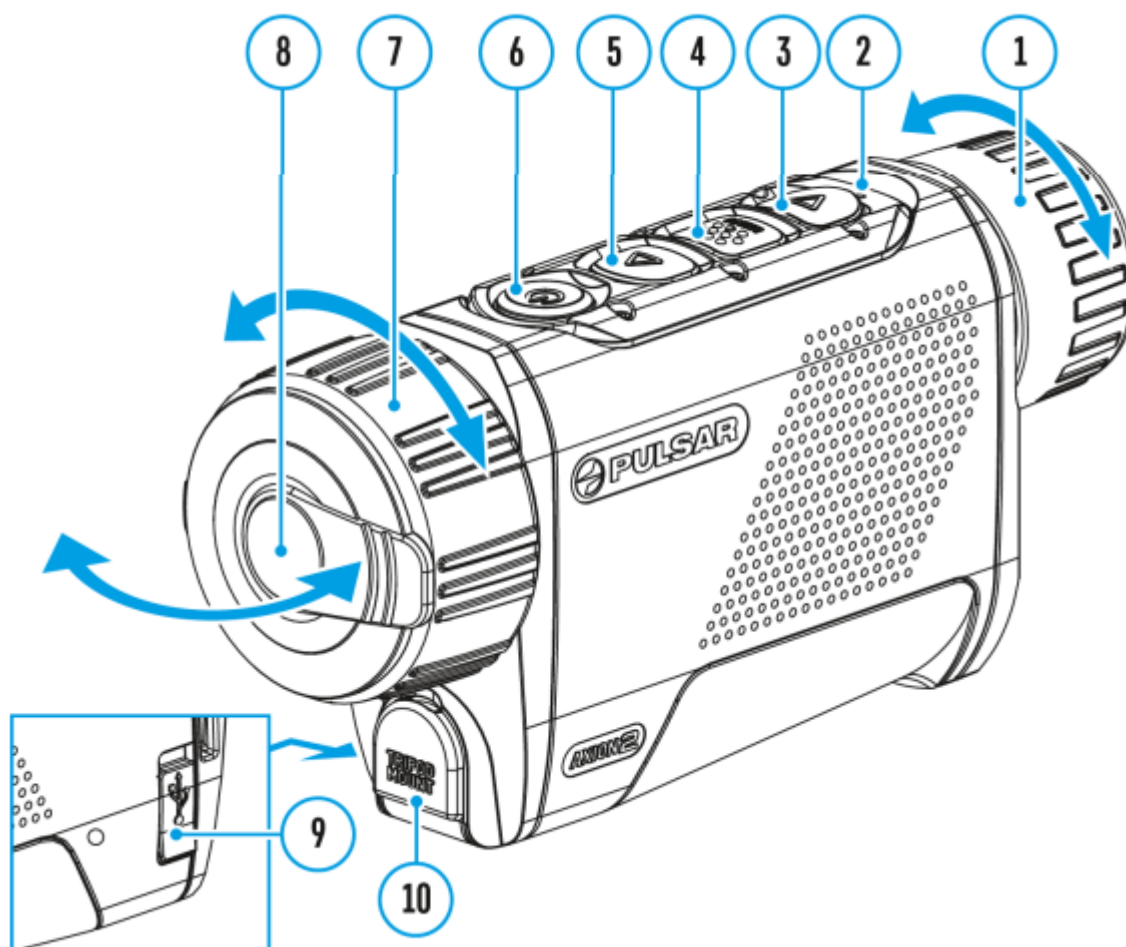

The basic settings (adjusting brightness and contrast, using the Stadiametric Rangefinder function) can be changed using the quick access menu.

- Enter the menu by briefly pressing the **MENU (4)**.
- A short press of the **MENU (4)** button enables you to toggle between functions, as described below.



Brightness



– press the **UP (5)/DOWN (3)** buttons to change display brightness from 0 to 20.

Contrast



– press the **UP (5)/DOWN (3)** buttons to change image contrast from 0 to 20.

**Note:** display brightness and contrast settings are saved in the memory when the device is turned off.

**Stadiometric Rangefinder**



– change the position of special marker lines to determine the distance to the object being observed by pressing the **UP (5)/DOWN (3)** buttons.

**Smooth Digital Zoom**



– press the **UP (5)/DOWN (3)** button to change the value of the digital zoom from 2 to 8. The digital zoom changes in 0.1 increments.

- Press and hold the **MENU (4)** button to exit the menu or wait for 10 seconds to exit automatically.

## Status Bar



The status bar at the bottom of the display shows current operating statuses via icons, including:

- Color Mode (shown only when the Black Hot color mode is selected)
- Amplification level
- Smoothing Filter (displayed when the function is on)
- Calibration Mode (in Automatic calibration mode a countdown timer

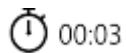

will appear instead of the calibration mode icon 3 seconds before automatic calibration begins).

- Microphone
- Magnification
- Wi-Fi Connection
- Time
- Power Indication:



-charge level if the device is powered by a battery



-charge level if the device is charging and powered by a battery



-no battery, the device is connected to an external power supply

---

## Functions

## USB Connection

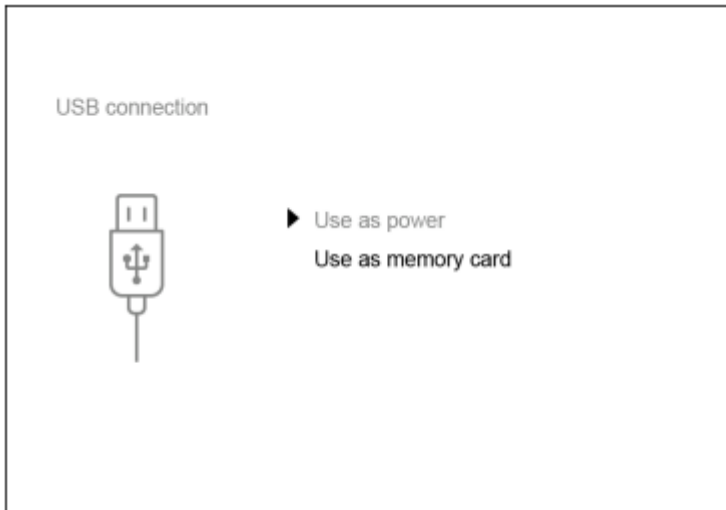
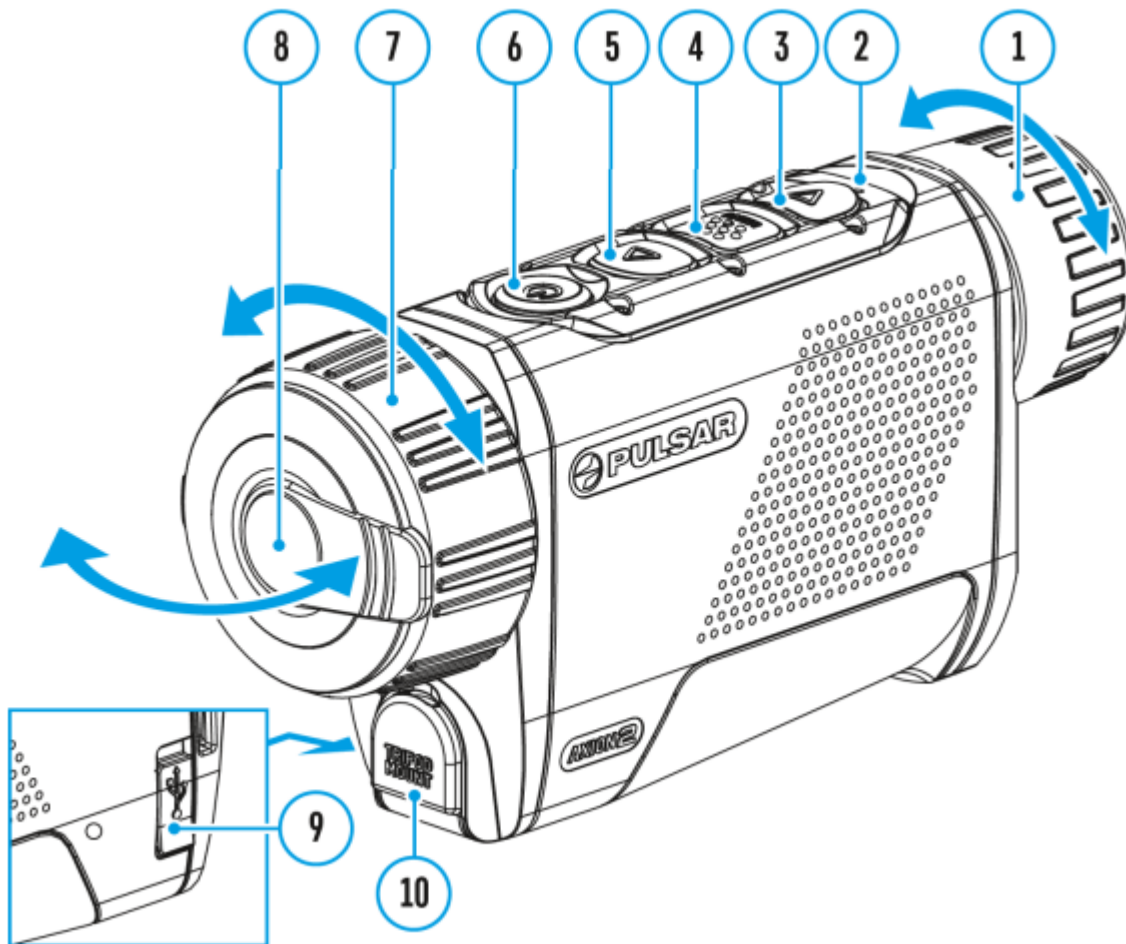

1. Connect one end of the USB cable to the USB Type-C port **(9)** of your device and the other end to the USB port of your PC / laptop.
2. Turn the device on with a short press of the **ON/OFF(6)** button (a device that has been turned off cannot be detected by your computer).
3. Your device will be detected by the computer automatically; no drivers need to be installed.
4. Two connection modes will appear on the display: **Power** and **Memory Card**(external storage device).
5. Select the connection mode with the **UP (5)/DOWN (3)** buttons.

6. Confirm the selection with a short press of the **MENU (4)** button.

## Power

- In this mode, a PC/laptop is used as an external power supply. The status bar shows the icon



- The device continues operating and all functions are available.
- Battery recharge feasibility depends on your computer's USB port.
- When the USB is disconnected from the device when in the **Power** mode, the device keeps operating with the Battery Pack if it is available and sufficiently charged.

## Memory Card (external memory)

- In this mode the device is detected by the computer as a flash card. This mode is designed for work with the files saved in the device's memory. The device's functions are not available in this mode; the device turns off automatically.
- If video recording was in progress when the connection was made, recording stops and the video is saved.
- When the USB is disconnected from the device where connection is in the **Memory Card** mode, the device remains in the Off state. Turn the device On for further operation.

# Installing the Device on a Tripod

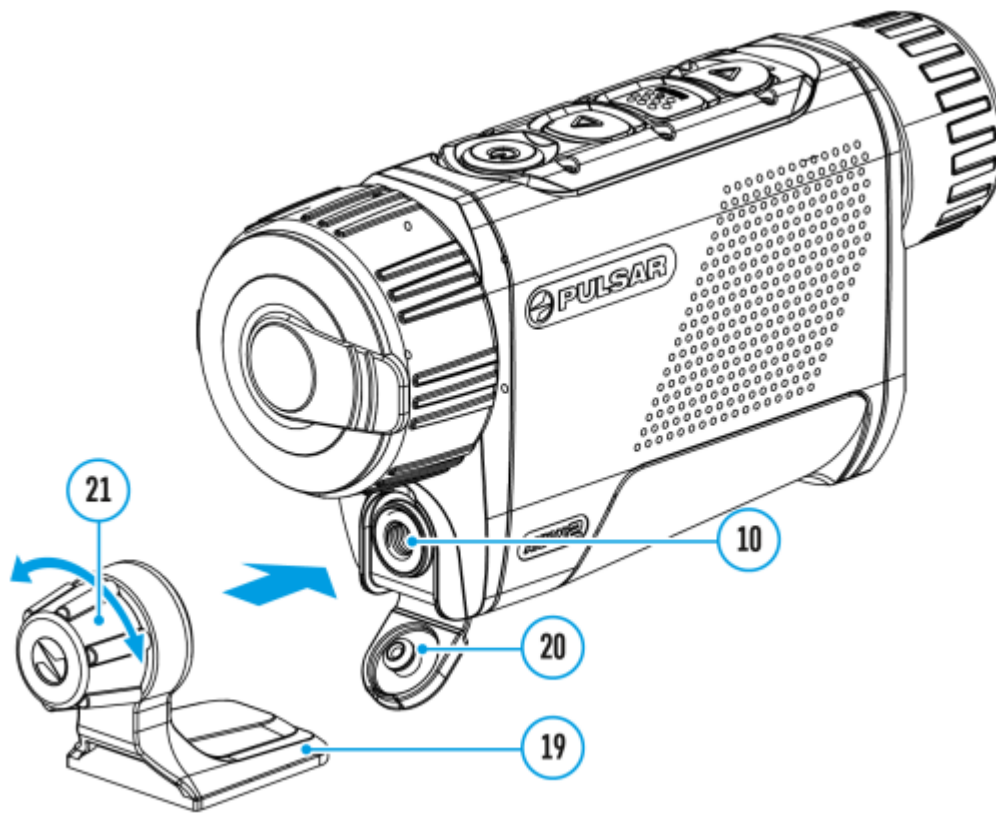

1. Open the cover **(20)** of the socket **(10)**.
2. Attach the tripod adaptor **(19)** to the socket **(10)**.
3. Rotate the adaptor handle clockwise until it stops.
4. Secure the adaptor with the device on a tripod.

## Stadiametric Rangefinder



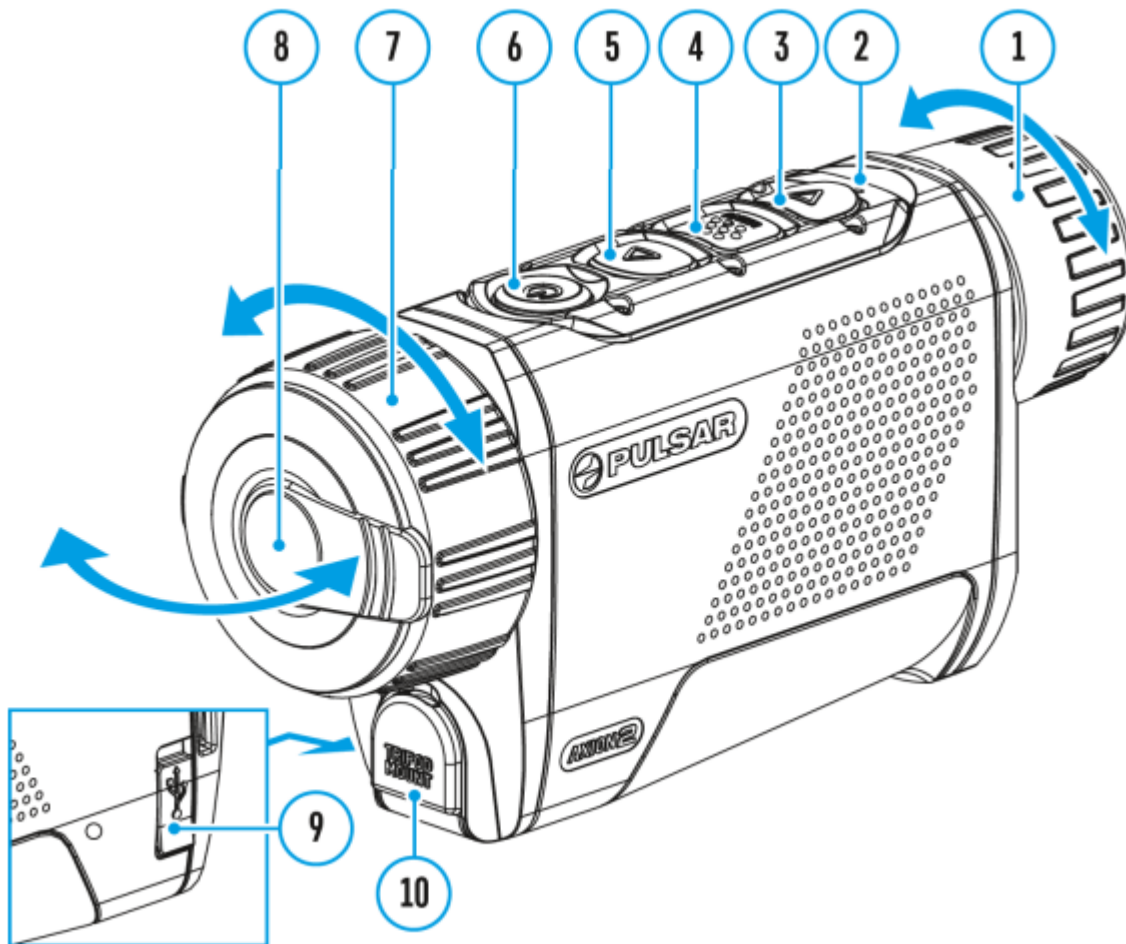

**Axion 2** thermal imagers are equipped with a stadiametric rangefinder which allows the user to determine the approximate distance to an object of a known size with reasonable accuracy.



1. Select the **Stadiametric Rangefinder** function with short presses of the **MENU (4)** button until the icon



is selected.

2. You will see on the display: measurement bars, icons of three reference objects and respective distances for the three objects.
3. Position the lower fixed bar under the object being ranged.
4. By pressing the **UP (5)/DOWN (3)** buttons, move the upper horizontal bar relative to the lower fixed bar until the object fits entirely between the two bars. The distance to the object is automatically recalculated as you move the upper line.
5. Exit the rangefinder mode with a long press of the **MENU (4)** button or wait 10 seconds to exit automatically.

#### Notes:

- There are three predefined values for the reference objects: Hare – 0.3 m height, Boar – 0.7 m height, Deer – 1.7 m height.
- Before it appears on the display, a measured distance value is rounded up to 5m for larger values and rounded down to 1m for smaller values.
- To select the unit of measurement (Meters or Yards), go to the General Settings



menu item ⇒ **Units of Measure**



submenu

## Wi-Fi Function





The device has a function enabling wireless communication with external devices (smartphone or tablet) via Wi-Fi.

- Turn on the wireless module in the WI-Fi Activation



menu option.

Wi-Fi is displayed in the status bar as follows:

Indication on the status bar	Connection Status
	Wi-Fi is switched off
	Wi-Fi connection is in progress
	Wi-Fi is switched on, no connection with device
	Wi-Fi is switched on, device connected

- The device is recognized by an external device as AXION2\_XXXX where XXXX are the four last digits of the serial number.
- After entering the password on the external device and setting up a connection, the icon



in the status bar changes to



## Display-Off Function

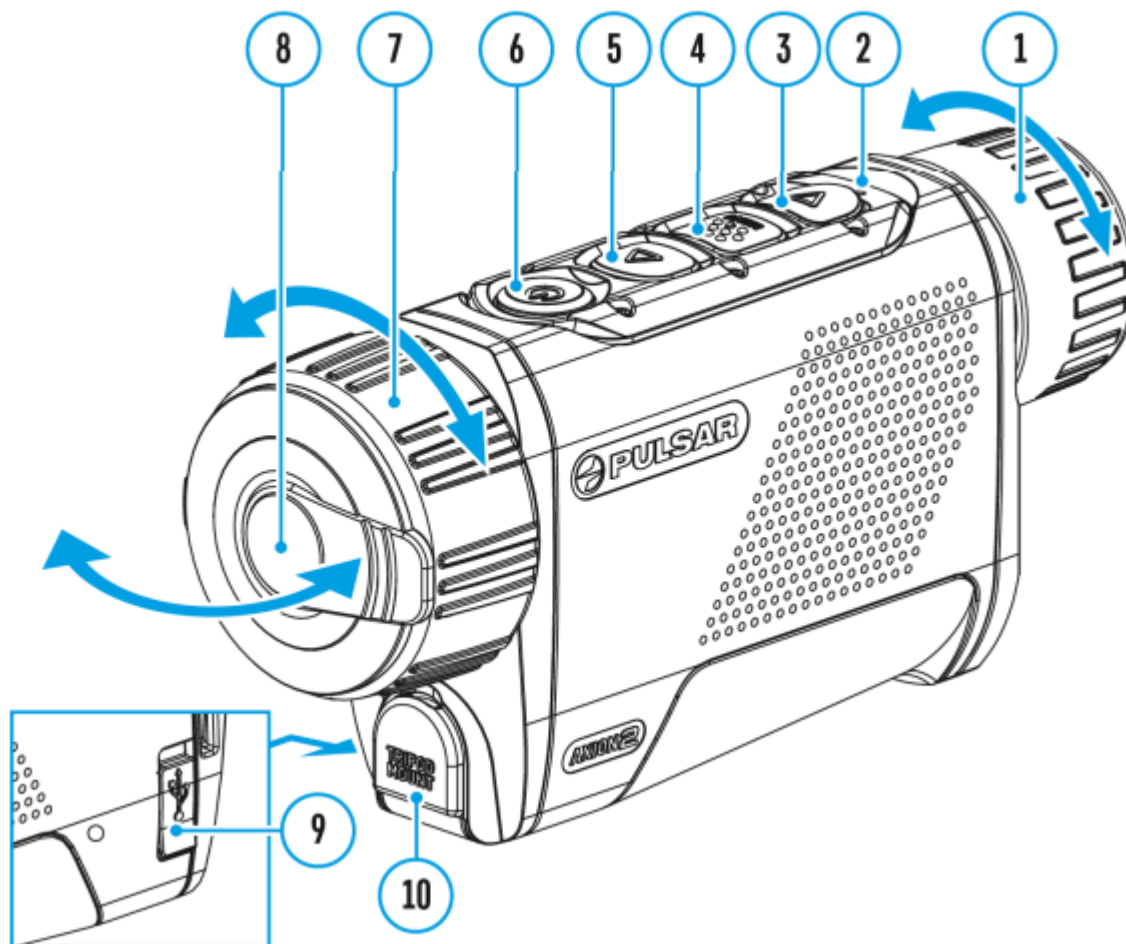

This function deactivates the image transmission to the display by minimizing its brightness. This allows the user to remain unseen. However, the device stays on.

When this function is in use, the device switches to the standby mode, which allows it to be switched on instantly.



1. When the device is on, press and hold the **ON/OFF (6)** button. The display will turn off, the current time and the **"Display off"** icon will appear.
2. Turn the display back on with a short press of the **ON/OFF (6)** button.
3. When you press and hold the **ON/OFF (6)** button, the display shows the **"Display off"** icon with a countdown. Pressing & holding the button down for the duration of the countdown will power the device off completely.

# PiP Function

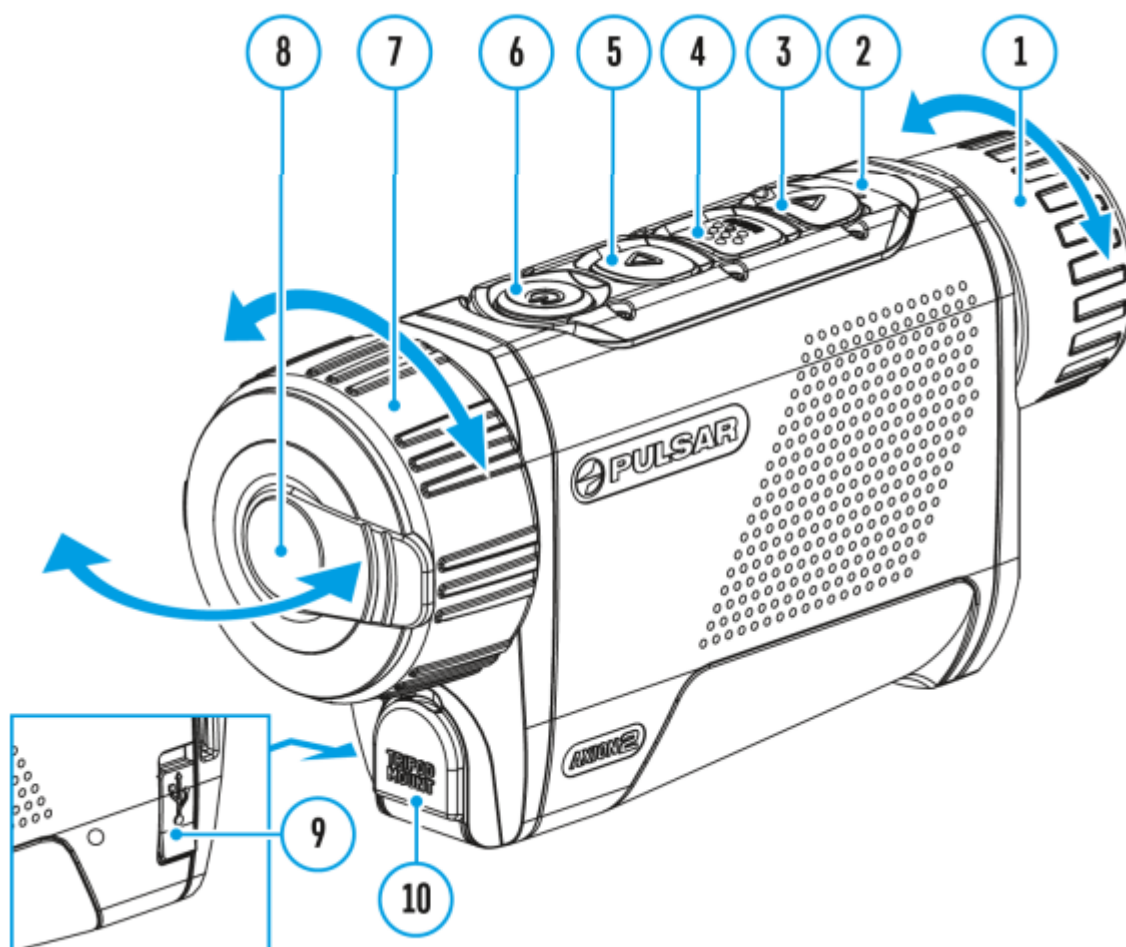

The **PiP** (Picture-in-Picture) function allows you to see both the main image and a magnified image in a dedicated window.

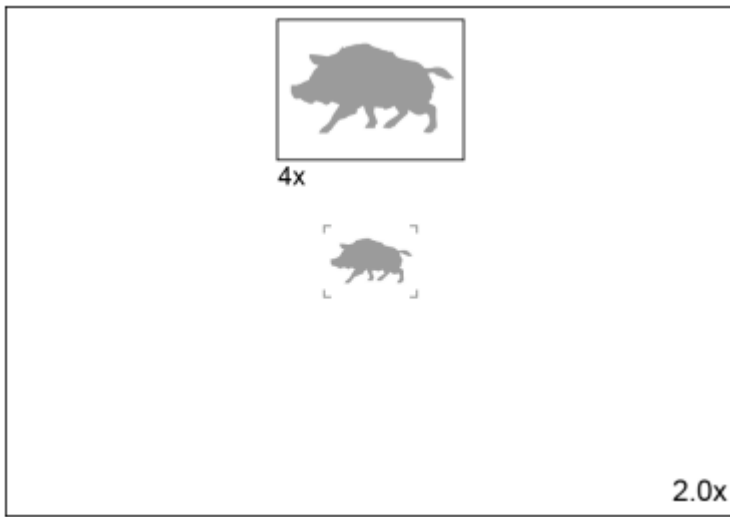

- To turn on and off the **PiP** function see the PiP Mode section.
- Press and hold the **UP (5)** button to change the magnification ratio in the **PiP** window.
- The zoomed image is displayed in a dedicated window, while the image in the rest of the screen is displayed at base magnification (2x).
- When the **PiP** is turned on you can control both the discrete and smooth digital zoom. In this case the zoom value changes only take place in the dedicated window.
- When the **PiP** function is turned off, the screen will display at the magnification that was set in **PiP**mode.

## Discrete Digital Zoom

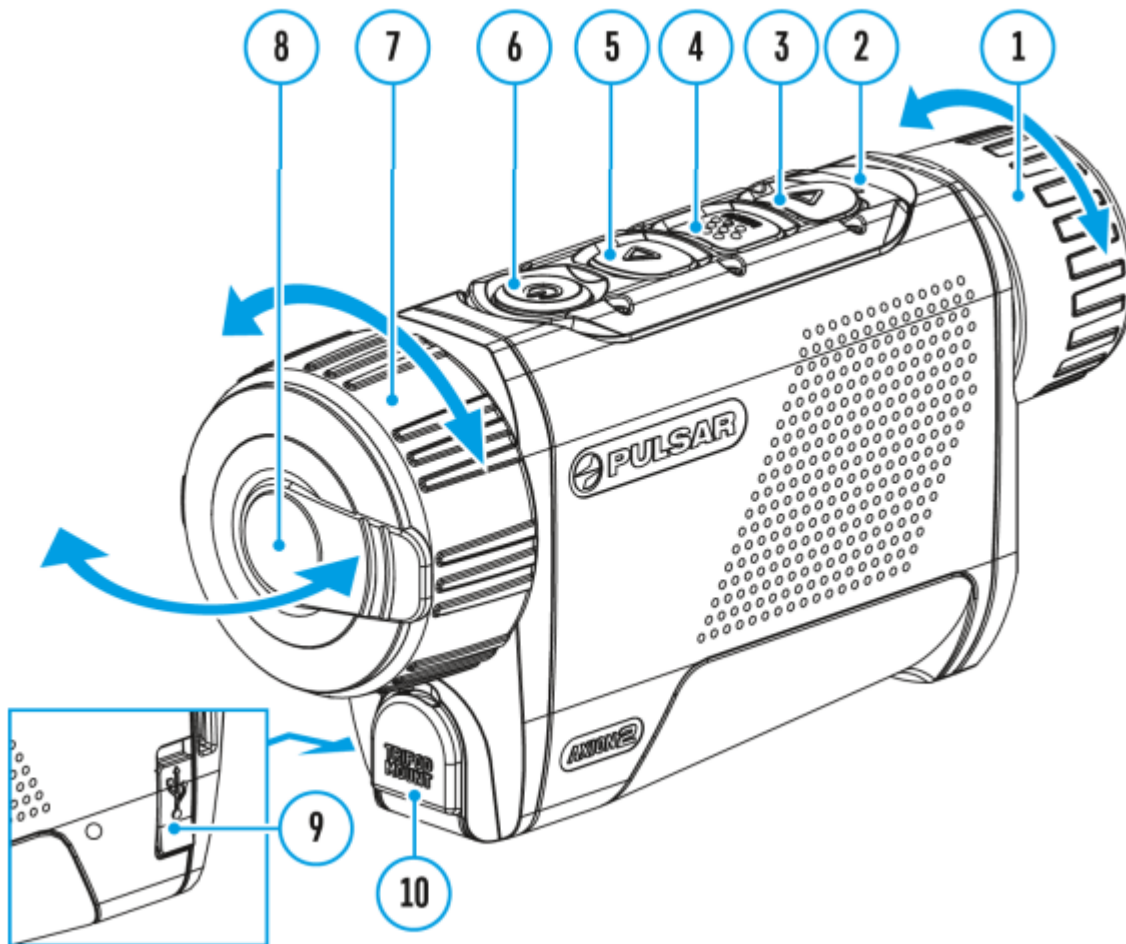

The device functionality allows you to quickly increase the base magnification by 2 or 4 times as well as return to the base magnification.



Press and hold the **UP/ZOOM (5)** button to change the digital zoom.

## Video Recording and Photography

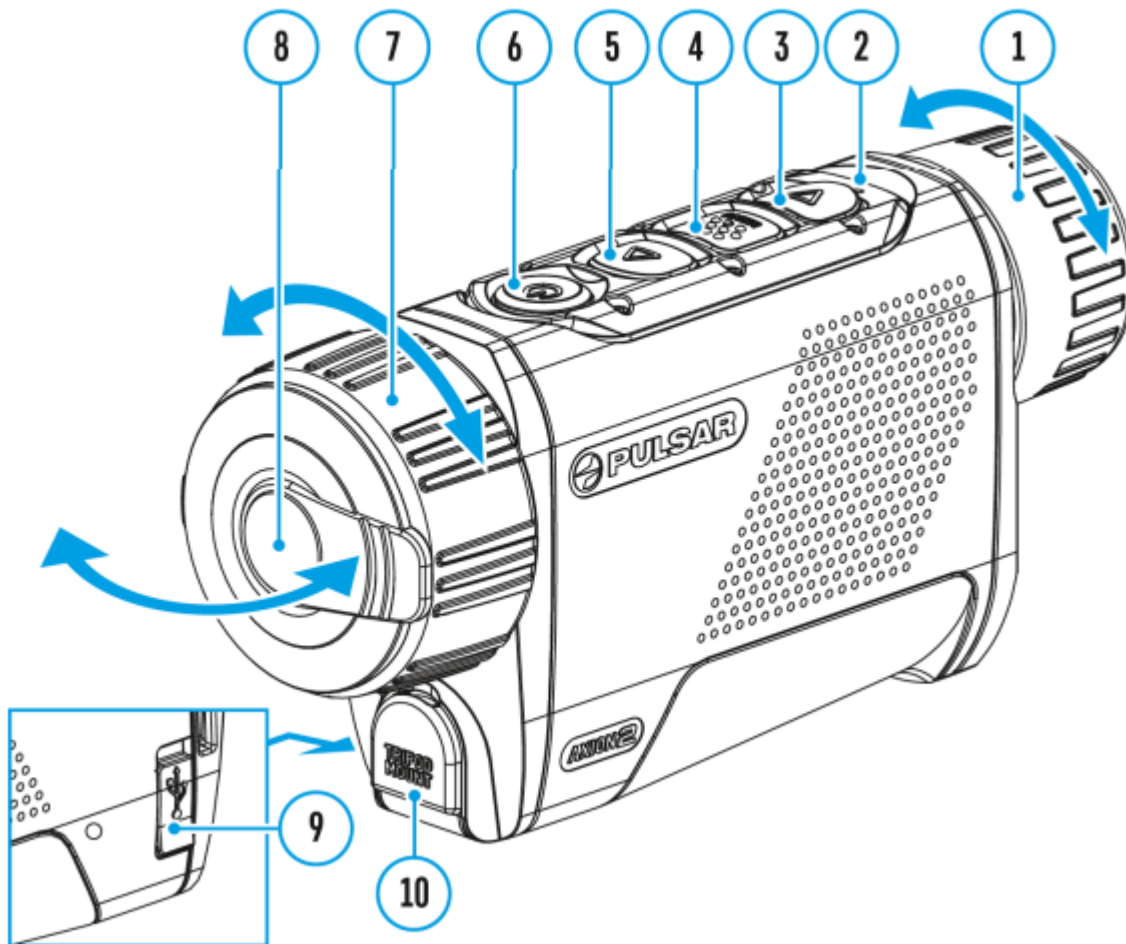

**Axion 2** thermal imagers feature video recording and photography of the image being observed to the internal memory card.

Before using this feature please set the **date** and **time**.

The built-in recorder operates in two modes – **Video** and **Photo**.

### Video mode. Video recording

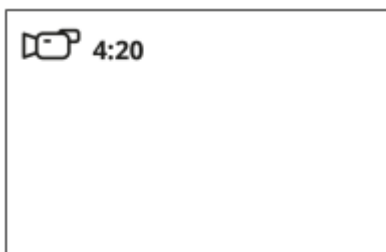

1. Switch to **Video** mode by pressing and holding the **DOWN/REC (3)** button.
2. The





icon and the remaining recording time in HH:MM (Hours:Minutes) format are displayed in the upper left corner, for example 4:20.

3. Press the **DOWN/REC (3)** button briefly to start video recording.
4. When the video recording starts, the icon



will disappear and the REC icon and timer in MM:SS (Minutes:Seconds) format will appear



5. Pause and resume recording video with a short press of the **DOWN/REC (3)** button.
6. Stop recording video with a long press of the **DOWN/REC (3)** button.
7. Video files are saved to the built-in memory card after the video recording has been stopped.
8. Press and hold the **DOWN/REC (3)** button to switch between the **Video** and **Photo** modes (Video→ Photo→ Video...).

### Photo Mode. Capturing an image



1. Switch to the **Photo** mode by pressing and holding the **DOWN/REC (3)** button.
2. Press the **DOWN/REC (3)** button briefly to take a photo. The icon



flashes – the photo file is being saved to the built-in SD card.

### Notes:

- You can enter and operate the menu during video recording.

- Recorded videos and photos are saved to the internal memory card in the format img\_XXX.jpg (photos), video\_XXX.mp4 (videos).
- The maximum duration of a recorded file is five minutes. After this time expires, a video is recorded into a new file. The number of recorded files is limited by the capacity of the device's internal memory.
- Regularly check the free capacity of the internal memory and move recorded footage to other storage media to free up space on the internal memory card.

## Amplification Level

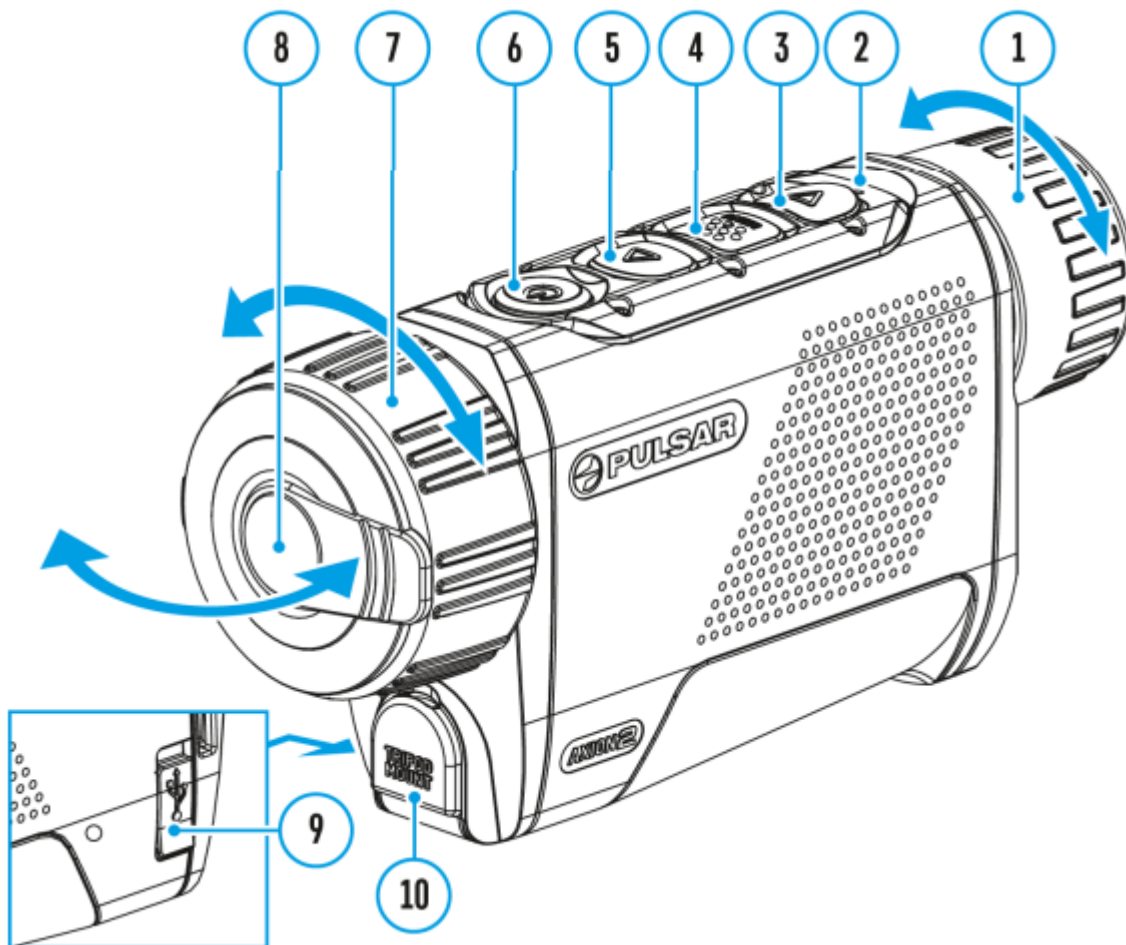

Sensitivity enhancement levels (Normal



, High



, Ultra



) are software algorithms that enhance the quality of detection and recognition in various observation conditions. When the temperature contrast decreases (fog, precipitation, high humidity), it is recommended to increase the amplification level. To optimize the image, activate the **Smoothing Filter** in the main menu.

Press the **UP** button **(5)** briefly to switch the amplification level.

---

## Software

### Firmware Update

1. Download free Stream Vision 2 App in **Google Play** or **App Store**.
2. Connect your Pulsar device to your mobile device (smartphone or tablet).
3. Launch Stream Vision 2 and go to section "Settings".
4. Select your Pulsar device and press "Check firmware update".
5. Wait for the update to download and install. Pulsar device will reboot and will be ready to operate.

### **Important:**

- if your Pulsar device is connected to phone, please turn on mobile data transfer (GPRS/3G/4G) to download update;
- if your Pulsar device is not connected to your phone but is already listed in "Settings" > "My devices" section, you may use Wi-Fi to download update.

### **Is your firmware up to date?**

Click [here](#) to check the latest firmware for your device.

## **Stream vision 2**



Install the Stream Vision 2 application to download files, update firmware, control the device by remote control and broadcast images from your device to a smartphone or a tablet via WiFi.

We recommend using the latest version – Stream Vision 2.

You can find further guidelines on Stream Vision 2 [here](#)

[Download from Google Play](#)

[Download from App Store](#)

---

# Maintenance

## Technical Maintenance and Storage

Maintenance should be carried out no less frequently than twice a year, and should consist of the following measures:

- Wipe external plastic and metal surfaces with a cotton cloth to remove dust and dirt. To avoid damage to the paint coating, do not use chemically active substances, solvents, etc.
- Clean the electric contacts of the Battery Pack and the device's battery slot using a non-greasy organic solvent.
- Check the objective and eyepiece lenses and if required, remove dust and dirt (preferably using a non-contact method). Cleaning of the exterior surfaces of the optics should only be done with products specifically designed for this purpose.
- Store the device in a carrying case. Remove the Battery Pack for longterm storage.

## Technical Inspection

It is recommended to carry out a technical inspection before each use of the device. Check the following:

- The device appearance (there should be no cracks on the body).
- The condition of the lens and eyepiece (there should be no cracks, grease spots, dirt or other deposits).

- The state of the rechargeable battery (should be charged) and the electric contacts (should be no signs of salts, oxidation or debris).
  - The controls should be in working order.
- 

# Troubleshooting

## **The device does not turn on**

### **Possible cause**

Battery Pack is discharged.

### **Solution**

Charge the Battery Pack.

---

## **The device does not operate from an external power source**

### **Possible cause**

The USB cable is damaged.

### **Solution**

Replace the USB cable.

### **Possible cause**

The external power supply is discharged.

### **Solution**

Charge the external power supply (if necessary).

---

**The image is blurry, with vertical stripes or an uneven background**

**Possible cause**

Calibration is required.

**Solution**

Perform the calibration according to Calibration Mode section.

---

**Black screen after calibration**

**Solution**

If the image does not clear after calibration, you need to recalibrate.

---

**Poor quality image. There is noise or ghost images of previous scenes or objects**

**Possible cause**

Manual calibration has been performed with the lens cover open.

**Solution**

Check the Calibration Mode, close the lens cover and calibrate the device.

---

**The image is too dark**

**Possible cause**

Brightness or contrast level is too low.

**Solution**

Adjust the brightness or contrast level in the Quick Menu.

---

## **Color bars appear on the display or the image disappears**

### **Possible cause**

The device was exposed to static electricity during operation.

### **Solution**

After exposure to static electricity, the device may either reboot automatically or require turning off and on again.

---

## **The image of the object being observed is missing**

### **Possible cause**

You are looking through glass.

### **Solution**

Remove the glass or change the viewing position to avoid it.

---

## **Poor image quality / Detection range reduced**

### **Possible cause**

These problems may occur during observation in adverse weather conditions (snow, rain, fog, etc.).

---

## **Smartphone or tablet PC cannot be connected to the device**

### **Possible cause**

Device password has been changed.

### **Solution**

Delete the network and connect again using the password saved in the device.

### **Possible cause**



The device is in an area with too many Wi-Fi networks that may be causing signal interference.

### **Solution**

To ensure a stable Wi-Fi connection, relocate the device to an area with fewer or no Wi-Fi networks.

### **Possible cause**

The device has a 5 GHz network enabled, but the smartphone only supports 2.4 GHz.

### **Solution**

Switch the device's Wi-Fi bandwidth to 2.4 GHz.

---

## **Wi-Fi signal is missing or interrupted**

### **Possible cause**

Smartphone or tablet is out of range of a strong Wi-Fi signal. There are obstacles between the device and the smartphone or tablet (e.g., concrete walls).

### **Solution**

Relocate smartphone or tablet into the Wi-Fi signal line of sight.

---

## **The image quality during the device operation at below zero temperatures is worse than at positive temperatures**

### **Possible cause**

Because of variations in thermal conductivity, objects (surrounding environment, background) under observation become warm more quickly at above-zero temperatures, which allows higher temperature contrast, so the quality of the image produced by a thermal imager will be better.

At low operating temperatures, objects under observation (background) normally cool down to roughly identical temperatures, which leads to reduced temperature contrast

and to image quality (precision) degradation. This is normal for thermal imaging devices.

---

## Package Contents

- Axion 2 thermal monocular
  - APS 5 rechargeable battery
  - 2 battery-locking covers
  - Power adapter
  - USB Type-C cable
  - Carrying case
  - Hand strap
  - Quick reference user manual
  - Lens cleaning cloth
  - Warranty information
  - Tripod adapter
- 

## Legal Compliances and Disclaimers

**Attention!** A license is required for Axion Thermal Imager when exporting outside your country.

**Electromagnetic compatibility.** This product complies with the requirements of European standard EN 55032: 2015, Class A.

**Caution!** Operation of this equipment in a residential environment could cause radio interference.

This product is subject to change in line with improvements to its design.

Repair of the device is possible within 5 years.

