

PULSAR MONOCULAR

Manual

[Description](#)

[Specifications](#)

[Package contents](#)

[Monocular installation](#)

[Legal compliances and disclaimers](#)

Description

The Pulsar 5×30 monocular converts the Krypton XG thermal imaging module into a handheld thermal imaging monocular with 5x magnification.

The monocular can be installed on the thermal imaging module without an additional adapter.

Specifications

Model	5x30 B
SKU	71013
Magnification, x	5
Lens diameter, mm/inch	30/1.18
Field-of-view, deg	7
Eye Relief, mm/inch	18/0.7
Eyepiece Focusing Range, Diopter	±5
Dimensions, mm/inch	130×47×51 / 5.12×1.85×2
Weight, kg/oz	167 / 5.89

Package contents

- Pulsar 5×30 B Monocular
 - Carrying Case
 - Lens-Cleaning Cloth
 - Operating Manual
-

Monocular installation

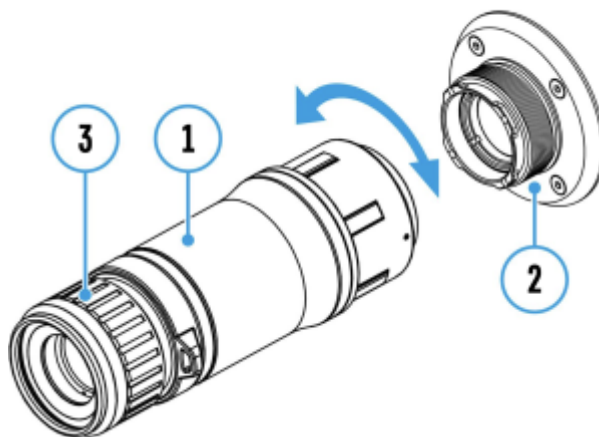

- 1.** Align the tabs on the monocular **(1)** with the slots of the mounting area **(2)** of the thermal imaging module.
- 2.** Turn the monocular clockwise to secure it on the thermal imaging module.
- 3.** Adjust the monocular's eyepiece diopter ring **(3)** until the symbols in the thermal imaging module's display are sharp.

4. To remove the monocular, turn it counterclockwise and disconnect from the thermal imaging module.

Note: the monocular can be installed on a thermal imaging module with a PSP Ring Adapter. The PSP Ring Adapter must be mounted onto the thermal imaging module until it stops.

Legal compliances and disclaimers

Updates of the Product. The manufacturer reserves the right at any time, without mandatory prior notice to the Customer, to make changes to the package contents (subject to the applicable laws, if any), design and characteristics that do not impair the quality of the Product.

Limitation of Liability. Subject to mandatory applicable laws and regulations: manufacturer will not be liable for any claims, actions, suits, proceedings, costs, expenses, damages or liabilities (if any), arising out of the use of this product. Operation and use of the product are the sole responsibility of the Customer. Manufacturer's sole undertaking is limited to providing the product(s) and related services in accordance with the terms and conditions of concluded transactions, including provisions established in warranty. The provision of products sold and services performed by Manufacturer to the Customer shall not be interpreted, construed, or regarded, either expressly or implied, as being for the benefit of or creating any obligation toward any third party (other than Distributor, Dealer, Buyer). Manufacturer's liability hereunder for damages, regardless of the form or action, shall not exceed the fees or other charges paid to Manufacturer for the product(s) and/or service(s).

MANUFACTURER WILL NOT BE LIABLE FOR LOST REVENUES OR INDIRECT, SPECIAL, INCIDENTAL, CONSEQUENTIAL, EXEMPLARY, OR PUNITIVE DAMAGES, EVEN IF THE MANUFACTURER KNEW OR SHOULD HAVE KNOWN THAT SUCH DAMAGES WERE POSSIBLE AND EVEN IF DIRECT DAMAGES DO NOT SATISFY A REMEDY.

For technical support please contact support@pulsar-vision.com.

Answers to frequently asked questions about the devices can also be found in the **FAQ** section.

