

# TRAIL 2 LRF Manual

## Specifications

### About the device

- Description
- Package Contents
- Features
- Components and Controls

### Power supply

- Precautions
- Battery Installation
- Battery Charging
- External Power

### Zeroing

- How to zero
- Add New Distance
- Zeroing Parameters Settings
- Windage/Elevation
- Magnification (when Zeroing)
- Freeze
- Name Distance
- Change Primary Distance
- Delete Distance

### Getting started

- Installation of Mount
- Powering on and Image Settings
- Button Operation

### Interface

- Status Bar
- Quick Menu Functions
- Main menu
  - Enter the Main Menu
  - Bluetooth
  - Mode
  - Image Detail Boost
  - Reticle Setup
  - Icon Brightness
  - Wi-Fi Activation
  - Calibration Mode
  - Microphone
  - Color Modes

- Rangefinder
- General Settings
- Wi-Fi Settings
- Side Incline
- Auto Shutdown
- Defective Pixel Repair
- Restore Default Pixel Map
- Device Information

## **Functions**

- Video Recording and Photography
- Built-In Laser Rangefinder
- Discrete Digital Zoom
- Ballistic Calculator
- PiP Function
- Display-Off Function
- Wi-Fi Function
- Scalable Reticles
- USB Connection

## **Software**

- Firmware Update
- Stream Vision 2

## **Maintenance**

- Maintenance and Storage
- Technical Inspection

## **Troubleshooting**

- The thermal riflescope will not turn on
- Device malfunction
- The riflescope does not operate on external power supply
- The image is blurry, with vertical stripes and uneven background
- Black screen after calibration
- When the device is turned on, the calibration frequency is at first higher, then decreases (if the automatic calibration mode is enabled)
- The image is too dark
- The reticle is blurred and cannot be focused with the diopter knob
- With a crisp image of the reticle, the image of the observed target that is at least 30 m away is blurred
- The point of impact shifts after firing rounds
- After zeroing, the aiming reticle moves relative to the centre of the display and the rangefinder reticle
- The riflescope will not focus
- Smartphone or tablet cannot be connected to the riflescope
- No Wi-Fi signal or erratic signal
- There is no image of the observed object
- Poor image quality / Detection range reduced

When using the riflescope at below zero temperatures the image quality is worse than at positive temperatures

Color stripes appear on the display or image disappears

Rangefinder does not measure distance

Large measurement error

The supplied USB cable is broken

## **Legal Compliances and Disclaimers**

# Specifications

## Model Trail 2 LRF

## XP50

SKU

76519

### Microbolometer

Type

uncooled

Resolution, Pixels

640×480

Frame Rate, Hz

50

Pixel Pitch,  $\mu\text{m}$

17

### Optical Characteristics

Objective Lens

F50 mm, F/1.2

Magnification, x

2

Digital Zoom, x

2-16

Discrete Digital Zoom

x2/x4/x8

Eye Relief, mm

50

Field of View (H),  $^{\circ}$

12.4

m@100m

21.8

Diopter Adjustment, D

+3/-5

Range of Detection, (Deer Type Object), m/y

1800/1968

Minimum Focusing Distance, m/y

5/5.5

### Reticle

Click Value, mm@100 m (H/V)

21 mm/21 mm

Click Range, mm@100 m (H/V)

4200/4200

## Display

|                    |           |
|--------------------|-----------|
| Type               | AMOLED HD |
| Resolution, Pixels | 1024x768  |

## Power Supply

|  |  |
|--|--|
| Battery Type / Capacity / Output Voltage | Li-Ion Battery Pack IPS7 / 6400 mAh / DC 3.7 V |
| Power Supply                             | 3-4.2 V  |
| External Power Supply                    | 5 V (USB)                                      |

## Operational Characteristics

|   |                        |
|---|------------------------|
| Max. Operating Time on Battery Pack (at t=22°C), Hours* | 8                      |
| Max. Recoil Power on Rifled Weapon, Joules              | 6000                   |
| Max. Recoil Power on Smooth-Bore Weapon, Caliber        | 12                     |
| Level of Protection (acc. to IEC 60529)                 | IPX7                   |
| Operating Temperature, °C / °F                          | -25...+50 / -13...+122 |
| Dimensions (LxWxH), mm                                  | 351x102x74             |
| inch  | 13.82x4.02x2.91        |
| Weight (w/o Batteries, Mount), kg                       | 0.8                    |
| oz  | 28.22                  |

## Video Recorder

|                                  |                                       |
|----------------------------------|---------------------------------------|
| Video / Photo Resolution, Pixels | 1024x768                              |
| Video / Photo Format             | .mp4 / .jpg                           |
| Built-In Memory                  | 16 GB                                 |
| Built-In Memory Capacity         | About 5 h video or > 100 000 pictures |

## Wi-Fi Channel\*\*

|           |         |
|-----------|---------|
| Frequency | 2.4 GHz |
|-----------|---------|

Standard 802.11 b/g

---

**Characteristics of the Rangefinder**

---

Wavelength, nm 905

---

Measurement Range, m/y\*\* 1000/1094

---

Measurement Accuracy, m +/-1

\* The actual operating time depends on the intensity of using Wi-Fi, video recorder, laser rangefinder.

\*\* Depends on the characteristics of the object under observation and environmental conditions.

# About the device

## Description

Thermal imaging riflescopes **Trail 2 LRF** are designed for the use on hunting rifles, both in the nighttime, and in the daylight in inclement weather conditions (fog, smog, rain) to see through obstacles hindering detection of targets (branches, tall grass, thick bushes etc.).

Unlike the image intensifier tube based night vision riflescopes, thermal imaging riflescopes do not require an external source of light and are not affected by bright light exposure.

**Trail 2 LRF** riflescopes are equipped with a high precision built-in laser rangefinder which allows distance measurement up to 1000 meters.

The **Trail 2 LRF** riflescopes have a wide range of applications including night hunting, observation and terrain orientation, search and rescue operations.

## Package Contents

- Trail 2 LRF Thermal Imaging Rifle scope
- IPS7 Battery Pack
- Battery charger with mains charger
- Carrying case
- MicroUSB cable
- Mount (with screws and hex-nut wrench(-es))\*
- Quick start guide

- Lens cloth
- Warranty card

\* The mount may not be included in certain orders.

## Features

- Built-in precise laser rangefinder
- High resolution thermal imaging microbolometer
- Rugged and light-weight magnesium alloy housing
- Long detection distance up to 1800 m
- Smooth and discrete digital zoom
- High caliber recoil resistance 12 gauge, 9.3×64, .375 H&H
- High refresh rate 50 Hz
- Zeroing profiles memorization
- Frost resistant AMOLED display
- Built-in video recorder
- Built-in Wi-Fi module
- Quick-change long-life rechargeable battery packs
- "Image Detail Boost" function
- "Picture-in-Picture" mode
- Manual contrast and brightness adjustment
- Variable electronic reticles
- Four operating modes: Forest, Rocks, Identification, User.
- Three calibration modes
- Storing photos and videos in Cloud when using the Stream Vision 2 App
- Ballistic calculator

## Components and Controls

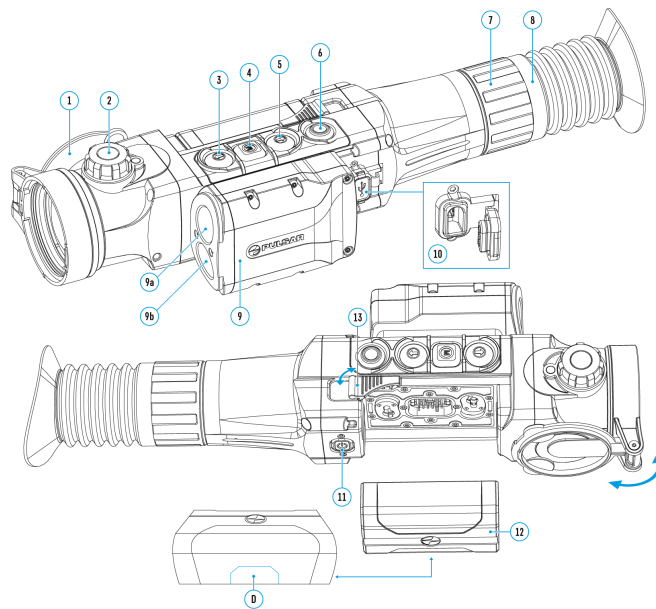

1. Lens cover
2. Lens focusing knob
3. Button UP
4. Button MENU (M)
5. Button DOWN
6. Button REC
7. Diopter adjustment ring
8. Eyeshade
9. Laser rangefinder:
  - 9a. Laser rangefinder's emitter
  - 9b. Laser rangefinder's receiver
10. MicroUSB port
11. Button ON/OFF/Calibration
12. Battery Pack
13. Lever for Battery Pack

# Power supply

## Precautions

- Only use the charger supplied with the Battery Pack. The use of any other charger may irreparably damage the Battery Pack or the charger and may cause fire.
- The batteries should be partially charged (50 to 80 %) for long-term storage.
- Do not charge battery immediately after bringing the battery from cold environment to a warm one. Wait for 30-40 minutes for the battery to get warm.
- Do not leave battery unattended while charging. Never use a modified or damaged charger.
- Charge Battery Pack at a temperature from 0 °C to +45 °C. Otherwise, battery's life will decrease significantly.
- Do not leave Battery Pack with a charger connected to the mains longer than 24 hours after full charge.
- Do not expose battery pack to high temperature or to a naked flame.
- Do not submerge battery in water.
- Do not connect external device with a current consumption that exceeds permitted levels.
- Battery Pack is short circuit protected. However, any situation that may cause short-circuiting should be avoided.
- Do not dismantle or deform Battery Pack. Do not drop or hit the battery.
- When using battery at negative temperatures, battery's capacity decreases, this is normal and is not a defect.
- Do not use battery at temperatures above those shown in the table — this may decrease the battery's life.
- Keep battery out of reach of children.

# Battery Installation

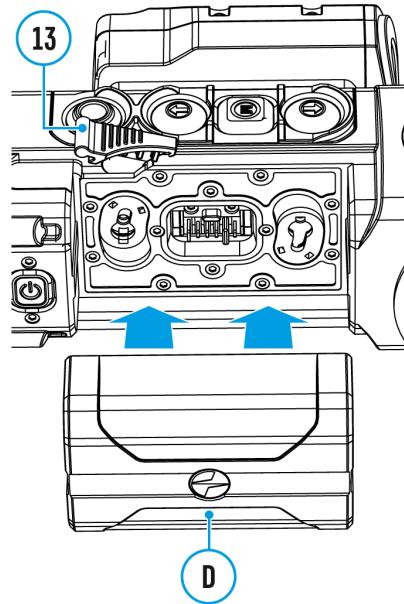

1. Remove protective cover from the Battery Pack.
2. Lift the lever **(13)**.
3. Install the battery into dedicated slot in the riflescope's housing so that element **D** is located below.
4. Lock the battery by pushing the lever **(13)** down.

# Battery Charging

Thermal imaging riflescopes are supplied with a rechargeable Li-Ion Battery Pack IPS7 which allows operation for up to 8 hours. Please remember to charge the Battery Pack before first use.

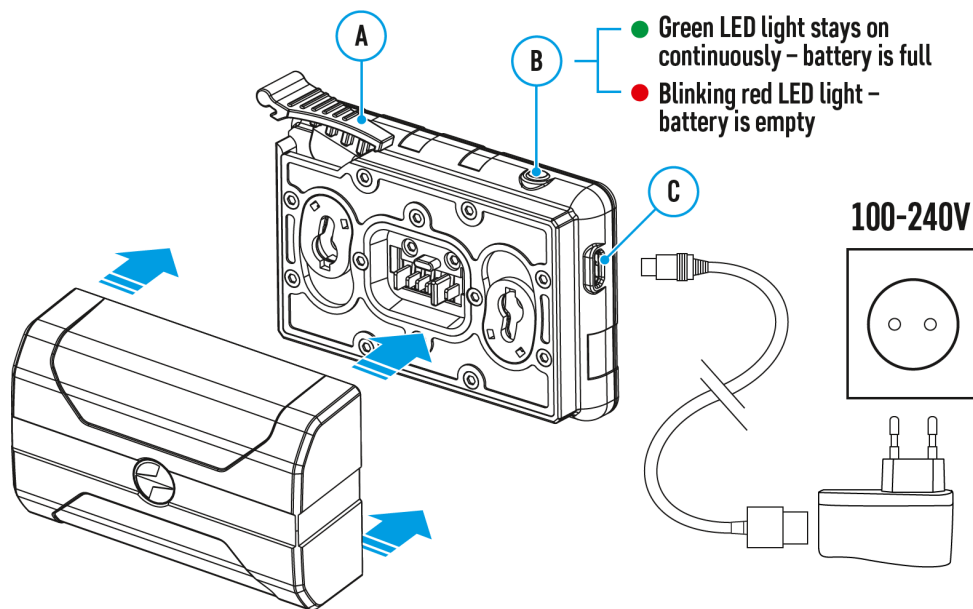

## Charging

### Step 1. Install the battery into the charger

1. Lift lever **(A)** of the charger.
2. Remove protective cover from the Battery Pack.
3. Insert the battery into the charger, as shown in the figure,
4. Push the lever **(A)** to full stop.

### Step 2. Check the current battery level

- Upon installation, a green LED indicator **(B)** on the charger will start to glow and begin flashing:
  - once if the battery charge ranges from 0% to 50%;
  - twice if the battery charge ranges from 51% to 75%;
  - three times if the battery charge ranges from 75% to 100%;
- If the indicator lights green continuously, the battery is fully charged.
- You can remove the battery from the charger by lifting the lever **(A)**.
- If the indicator of the charger lights red continuously upon battery installation, probably the battery's charge level is lower than acceptable (the battery has been long in deep discharge). Keep the battery in the charger for a long time (up to several hours), remove and re-insert it.
- If the indicator starts blinking green, the battery is good;
- If the indicator keeps lighting red, the battery defective. **Do not use the battery!**

**The LED indicator (B) will display the battery charge status:**

**LED Indicator (B)****Battery Charge Status**

Battery is empty



Battery is full

**Step 3. Connect the charger to the mains supply**

1. To charge the battery, connect the MicroUSB plug of the USB cable to port **(C)** of the charger.
2. Connect the plug of the USB cable to the mains adapter.
3. Plug the mains adapter into a 100 – 240 V socket – the battery charging process will start.

## External Power

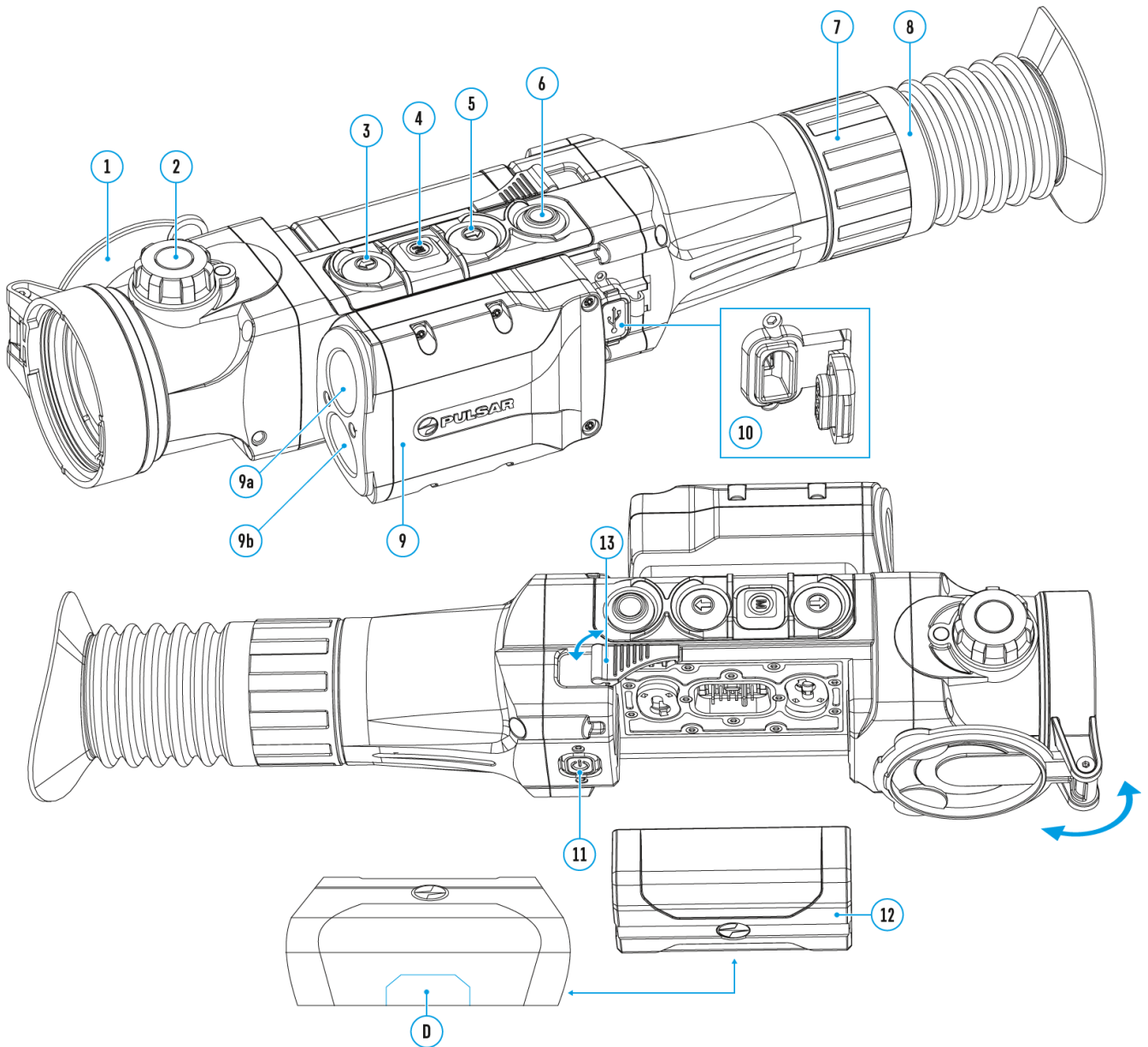

The riflescope can be powered with an external power supply such as Power Bank (5V).

1. Connect external power supply to USB port **(10)** of the riflescope.
2. The riflescope switches to operation from external power supply, and the IPS7 Battery Pack will begin charging slowly.
3. Display will show a battery icon



with charge level as a percentage.

4. If the riflescope operates on external power supply but the Battery Pack is not installed, an icon



is shown.

5. When external power supply is disconnected, the riflescope switches to the internal IPS7 battery pack without powering off.

**Attention!** Charging IPS7 batteries from Power Bank at air temperatures below 0 ° C may result in reduced battery life. When using external power, connect Power Bank to the switched-on riflescope, which has worked for several minutes.

# Zeroing

## How to zero

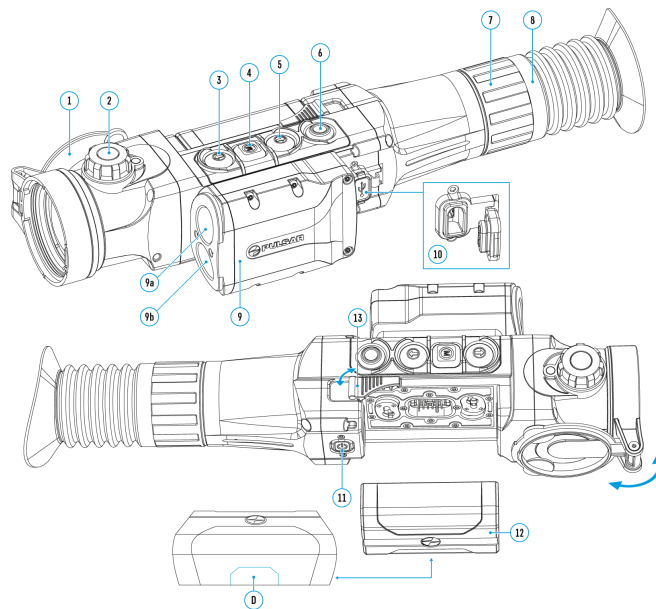

Zeroing is recommended to be done at the temperature close to the riflescope operating temperature.

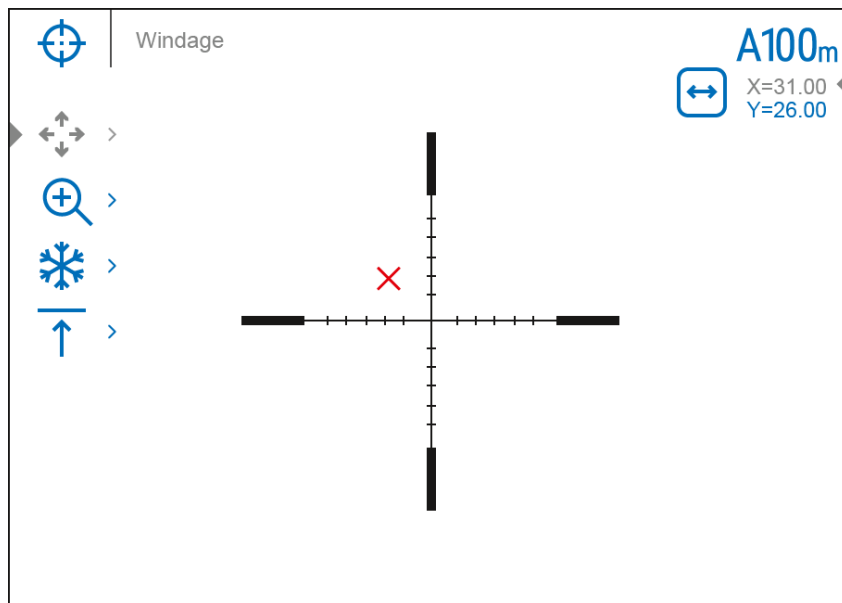

Zeroing should be done at operating temperatures, by following these steps:

### Step 1. Make a shot

1. Mount your rifle with the riflescope installed on a bench rest.
2. Set a target at a certain distance.
3. Adjust the riflescope according to the instructions of section **Powering On and Image Setting**.
4. Select zeroing profile (see **Reticle Setup**



→ **Zeroing Profile**



main menu item).

5. Point a rifle at the center of the target and shoot.

---

### Step 2. Align the reticle with the impact point

1. If the point of impact does not match the aiming point (center of the riflescope's reticle), hold down **M (4)** button to enter the main menu.
2. Select submenu **Reticle Setup**



with **UP (3)/DOWN (5)** buttons.

3. Enter submenu with a short press of **M (4)** button.
4. Add a new zeroing distance at which you are zeroing (see **Reticle Setup**



menu item ⇒ submenu **Add New Distance**



).

5. Additional menu for **Zeroing**



appears on the display.

6. An auxiliary cross



appears in the center of display, and coordinates of the auxiliary cross X and Y appear in the top right corner.

7. Enter **Windage/Elevation**



submenu with a short press of **M (4)** button.

8. Holding the reticle at the aiming point, move the auxiliary cross horizontally or vertically with **UP (3)/DOWN (5)** buttons until the auxiliary cross matches the point of impact. Switch between movement directions of the auxiliary cross from horizontal to vertical with a short press of **M (4)** button.
-

## Zoom Zeroing function:

To improve the accuracy of zeroing, you can change the magnification in the menu



. The larger the magnification, the smaller the step of shifting the reticle on the display relative to the image from the sensor.

## One-shot "Freeze Zeroing" function:

Not to hold the reticle at the aiming point, you can use the **Freeze** function – freezing the zeroing screen (refer to **Reticle Setup**



menu item ⇒ **Distance** submenu ⇒ **Zeroing**

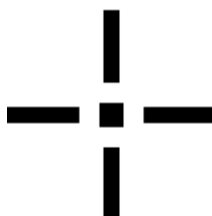

submenu ⇒ **Freeze**



submenu or short pressing of the **ON/OFF (11)** button).

---

## Step 3. Save the coordinates

1. To save the new reticle position, press and hold the **M (4)** button. The reticle is aligned with the point of impact and the submenu



exits.

2. Press and hold the **M (4)** button again to exit the zeroing settings menu – the message “Zeroing coordinates saved” appears, confirming the successful operation.
  3. Take another shot — the point of impact should now match the aiming point.
- 

*Notes:*

- To re-zero at any distance select the desired distance in **Reticle Setup**



submenu, press **M (4)** button briefly and enter **Zeroing**



submenu with another short press of **M (4)** button.

- After zeroing, the reticle may not be in the center of the display.
- The range of movement of the riflescope reticle allows you to successfully zero the riflescope, even on mounts that are far from ideal, minimizing the possible disadvantages of the mounts. The better the mount is installed, the less you have to move the reticle. We recommend mounting the riflescope as low as possible.

## Add New Distance

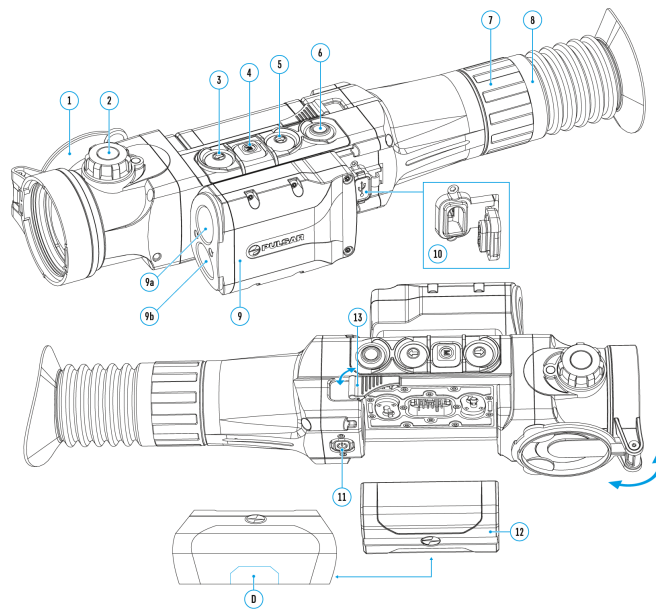

To zero your rifle, you need to set a zeroing distance first. You can zero your rifle at any distance ranging from 1 to 910m (1 to 955 yards).

1. Enter the main menu with a long press of **M (4)** button.
2. Press **UP (3)/DOWN (5)** buttons to select **Reticle Setup**



menu item.

3. Enter submenu Reticle Setup with a short press of **M (4)** button.
4. Enter submenu **Add New Distance**



with a short press of **M (4)** button.

5. Set values for each digit with **UP (3)/DOWN (5)** buttons. Switch between the digits



with a short press of **M (4)** button.

6. Having set the desired distance value, hold down **M (4)** button to save it.

The distance you set first becomes a **primary distance** – shown with an icon



on the right to the distance value.

**Note:** max. number of zeroing distances is 10 for each profile.

## Zeroing Parameters Settings

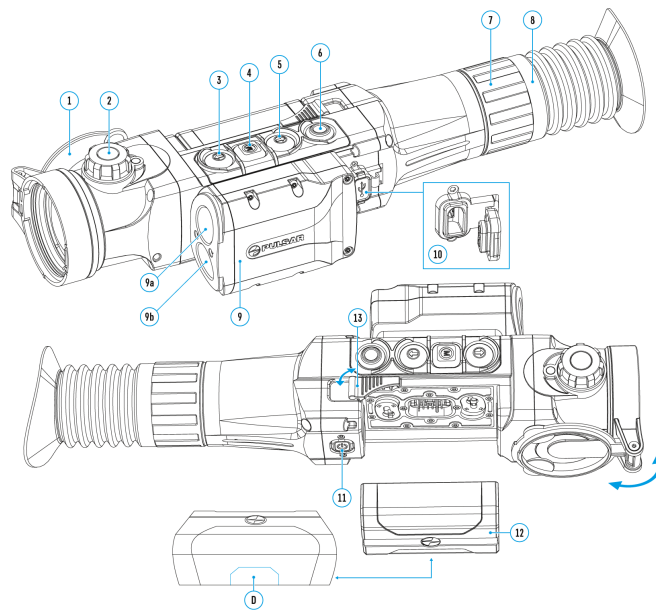

1. Press and hold **M (4)** button to enter the main menu.
2. Press **UP (3)/DOWN (5)** buttons to select the **Reticle Setup**



menu item and enter by briefly pressing **M (4)** button – the zeroed distances are displayed.

3. The values (e.g., +7.0) shown on the right of the distance values, stand for the number of clicks along the Y axis, at which the reticle position at other distances

differs from the reticle position in the primary distance.

4. To zero at any distance again, press **UP (3)/DOWN (5)** buttons to select the required distance and briefly press **M (4)**.
5. Press **UP (3)/DOWN (5)** buttons to select the **Zeroing**



and enter by briefly pressing **M (4)**.

6. **Zeroing** screen, which allows the change of zeroing coordinates, will appear.

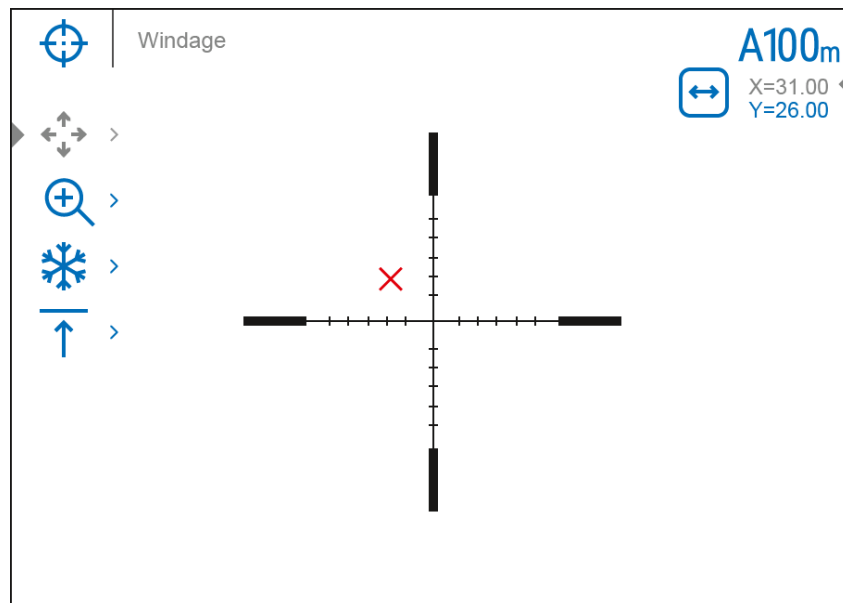

## Windage/Elevation

The **Windage/Elevation**

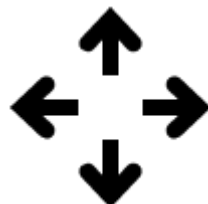

additional menu item in the **Zeroing**



menu allows you to adjust the reticle position. For a detailed description of the reticle adjusting, refer to the **How to zero** section

## Magnification (when Zeroing)

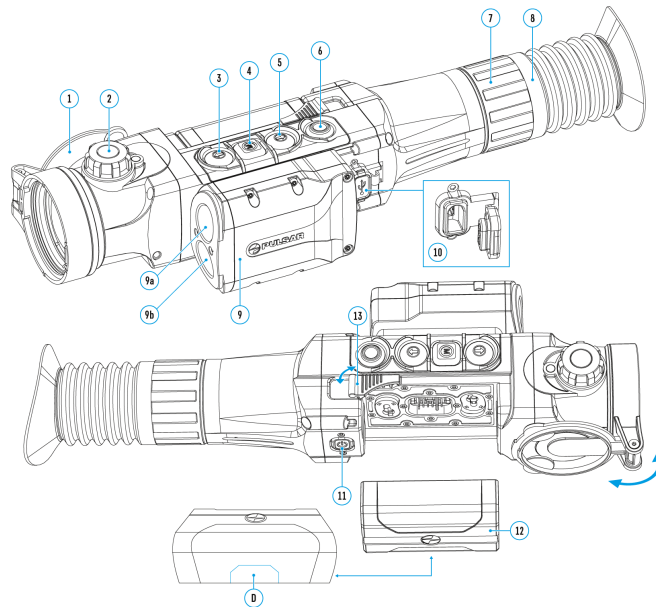

Magnification allows you to magnify a digital zoom of the riflescope when zeroing, which reduces the minute of angle click. It improves the zeroing accuracy.

1. In the **Zeroing**



menu, press **UP (3)/DOWN (5)** buttons to select the **Magnification**



submenu item and enter by briefly pressing **M (4)** button.

2. Press **UP (3)/DOWN (5)** buttons to select a digital magnification value of the riflescope (e.g., x4).
3. Press **M (4)** button briefly to confirm your selection.

The minute of angle click when using the Magnification function is indicated in the Table of **Technical Specifications**.

## Freeze

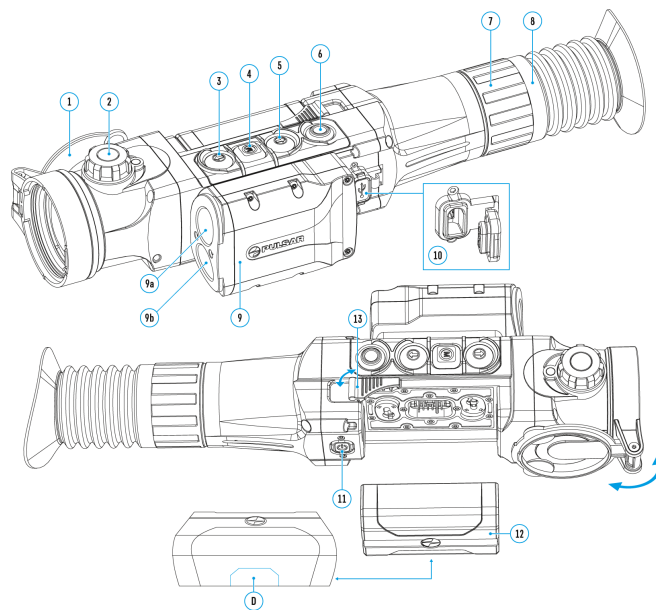

The feature of the function is that there is no need to constantly keep the riflescope at the point of aiming.

1. In the **Zeroing**



menu, press **UP (3)/DOWN (5)** buttons to move the cursor to the **Freeze**



function.

2. Align the reticle with the point of aiming and press **M (4)** or **ON/OFF (11)** button. A screenshot will be taken, an icon



will appear.

3. Go to the additional **Windage/Elevation**



submenu and adjust the position of the reticle (see the **How to zero** section).

4. Select the **Freeze**



submenu item again and briefly press **M (4)** or **ON/OFF (11)** button – the image will “unfreeze”.

## Name Distance

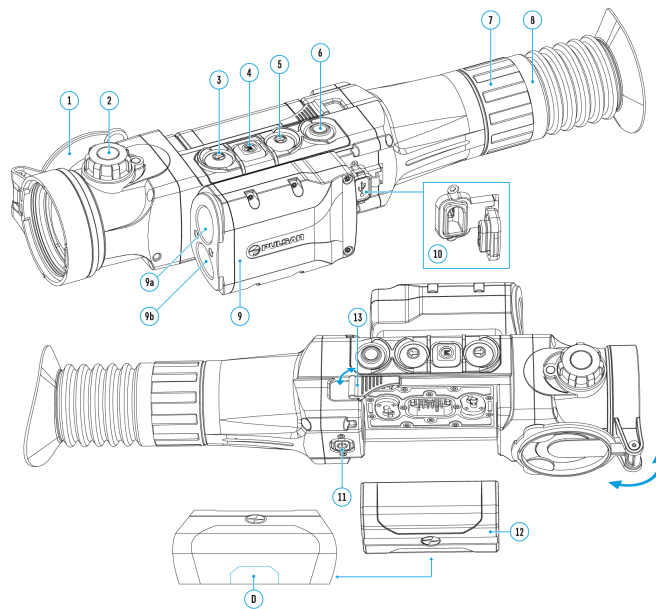

## 1. In the **Zeroing**



menu, press **UP (3)/DOWN (5)** buttons to select the **Name Distance**



submenu item and enter it by briefly pressing **M (4)** button.

2. Press **UP (3)/DOWN (5)** buttons to select a value for each digit. Press **M (4)** button briefly to switch between digits.
3. Press and hold **M (4)** button to confirm the selection.

# Change Primary Distance

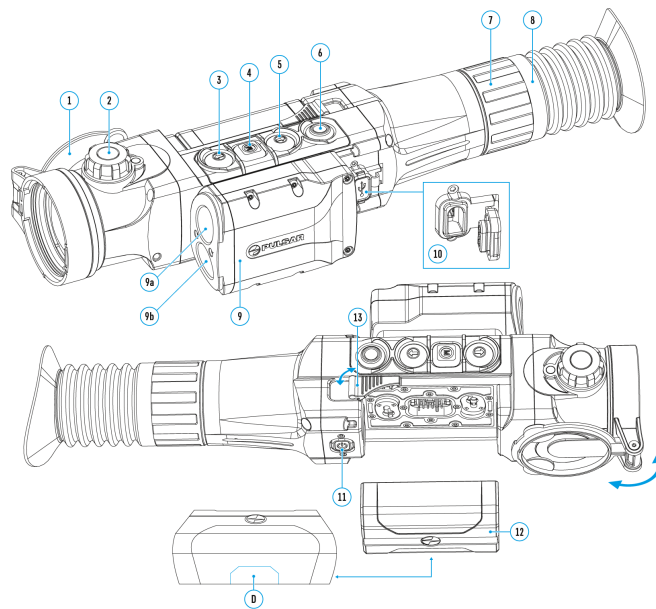

1. Press and hold **M (4)** button to enter the main menu.
2. Press **UP (3)/DOWN (5)** buttons to select the **Reticle Setup**



menu item and enter by briefly pressing **M (4)** button – the zeroed distances are displayed.

3. Select a non-primary distance and enter the submenu for operating the distance with a brief press of **M (4)** button.
4. Select **Change Primary Distance**



item .

5. Press **M (4)** button briefly.
6. Icon



next to the selected distance confirms the change of primary distance.

The differences of other distances from the new primary distance are recalculated as per clicks.

# Delete Distance

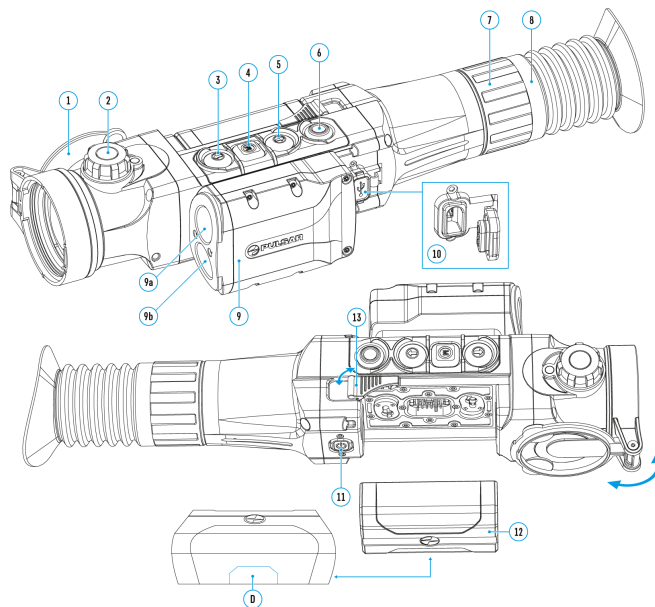

1. Press and hold **M (4)** button to enter the main menu.
2. Press **UP (3)/DOWN (5)** buttons to select the **Reticle Setup**



menu item and enter by briefly pressing **M (4)** button – the zeroed distances are displayed.

3. Select the distance you wish to delete and enter the submenu for operating the distances with a brief press of **M (4)** button.
4. Select **Delete Distance**



item.

5. Select "Yes" in the appeared dialog box to delete a distance. "No" – to cancel deletion.

**Attention!** If the primary distance is deleted, the first distance on the list automatically becomes the new primary distance.

# Getting started

## Installation of Mount

Before using the riflescope you need to install a mount (may not be included).

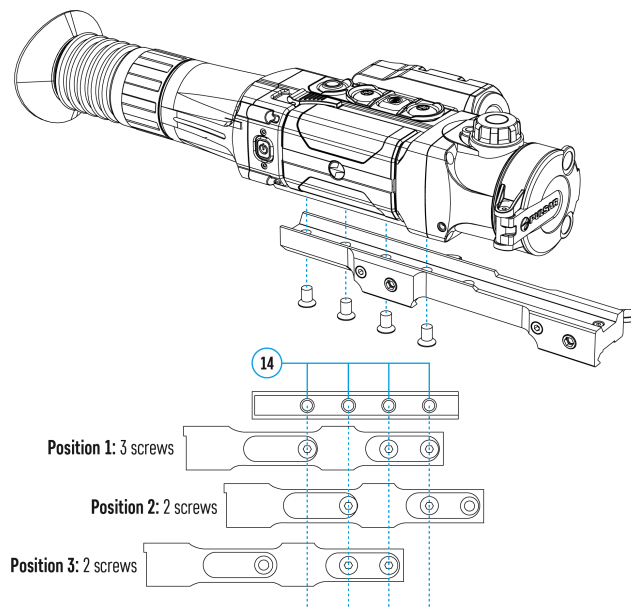

Mounting holes (**14**) in the base of the riflescope enable the mount to be installed in one of the multiple positions. The choice of the mounting position helps the user to ensure correct eye relief depending on rifle type.

1. Attach the mount to the base of the riflescope using a hex-nut wrench and screws.
2. Install the riflescope on the rifle and check if the position is suitable for you.
3. If you are happy with its position, remove the riflescope, unscrew the screws halfway, apply some thread sealant onto the thread of the screws and tighten them fully (do not over-tighten). Let the sealant dry for a while.
4. The riflescope is ready to be installed on the rifle and to be zeroed. Recommended torque force for the side screws of the Weaver mount is 2 Nm to 3 Nm (17.7 in-lbs to 26.6 in-lbs).

5. After first installation of your riflescope on a rifle, please follow instructions in section **Zeroing**.

**Warning!** Do not point objective lens of unit at intensive sources of light such as riflescope emitting laser radiation or the sun. This may render electronic components inoperative. Warranty does not cover damage caused by improper operation.





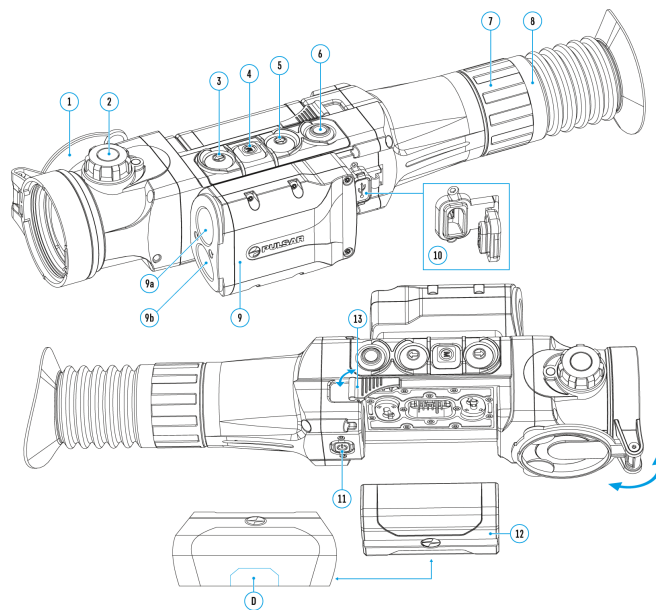







## Rifle Mounts Catalogue

# Powering on and Image Settings



1. Open lens cover **(1)**.
2. Turn the unit on with a short press of **ON/OFF (11)** button.
3. To obtain a crisp image of icons on display, rotate diopter adjustment ring **(7)**. After this there is no need to rotate the diopter adjustment ring for distance or any other conditions.
4. To focus on an object being observed rotate lens focusing knob **(2)**.
5. To set up display brightness and contrast and smooth zoom, please refer to the section **Quick Menu Functions**.
6. After use, hold down **ON/OFF (11)** button to turn the riflescope off.

# Button Operation

| Operation                          | Button   |
|------------------------------------|--|
| Power riflescope on                | <br>short press                     |
| Power riflescope off               | <br>long press for 3 secs           |
| Turn display off                   | <br>long press for less than 3 secs |
| Turn display on                    | <br>short press                     |
| Calibrate the microbolometer       | <br>short press                   |
| Switch color palettes              | <br>short press                   |
| Control discrete digital zoom      | <br>short press                   |
| PiP on/off                         | <br>short press                   |
| Video Recorder                     | Button   |
| Start/pause/resume video recording | <br>short press                   |
| Stop video recording               | <br>long press                    |
| Switch to video / photo modes      | <br>long press                    |
| Capture Photo                      |                                   |

short press

---

## Rangefinder

### Button

---

Activate rangefinder's stand-by mode



short press

---

Measure distance



short press (in rangefinder's stand-by mode)

---

Activate SCAN mode



long press (in rangefinder's stand-by mode)

---

Deactivate SCAN mode



short press

---

## Main Menu

### Button

---

Enter main menu



long press

---

Navigation upwards/rightwards



short press

---

Navigation downwards/leftwards



short press

---

Confirm selection



short press

---

Exit submenu without confirming selection



long press

---

Exit menu (switch to viewing mode)



long press

---

## Quick Menu

### Button

---

Enter quick menu



short press

---

Switch between quick menu options



short press

---

Increase value



short press

---

Decrease value



short press

---

Exit quick menu



long press

# Interface

## Status Bar

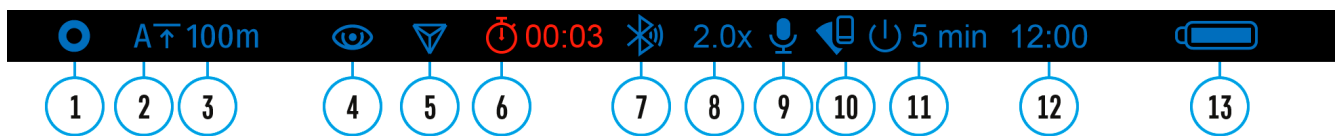

The status bar is located in the lower part of the display and shows current operating status of the riflescope, including:

1. Image inversion mode (only Black Hot)
2. Current zeroing profile (for example A)
3. Zeroing distance (for example, 100 m)
4. Operating mode (for example Forest)
5. Image Detail Boost (displayed when the function is on)
6. Calibration mode (in the automatic calibration mode, three seconds before automatic calibration a countdown timer

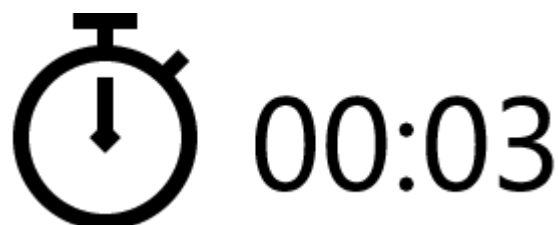

is shown in place of the calibration mode icon)

7. Bluetooth:



– Bluetooth pairing



– the device with Bluetooth is connected

**8.** Current full magnification (for example 2.0x)

**9.** Microphone

**10.** Wi-Fi connection status

**11.** Function “Auto shutdown” (for example 5 min)

**12.** Current time

**13.** Power indication:

- Battery charge level



(if the riflescope is powered by the Battery Pack).

- External battery power indicator



(if the riflescope is powered by an external power supply).

## Quick Menu Functions

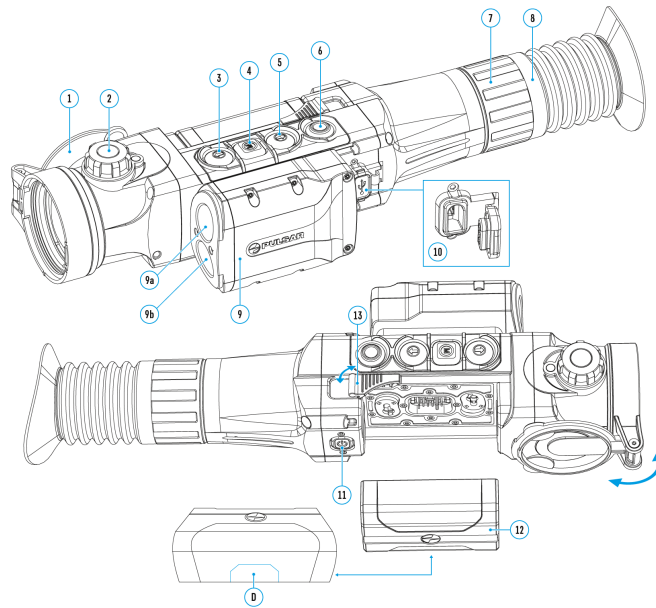

The Quick Menu allows to change the basic settings (display brightness and contrast, discrete digital zoom and zeroing distance).

- Enter the menu with a short press of **M (4)** button.
- To select the functions below, press successively **M (4)** button.

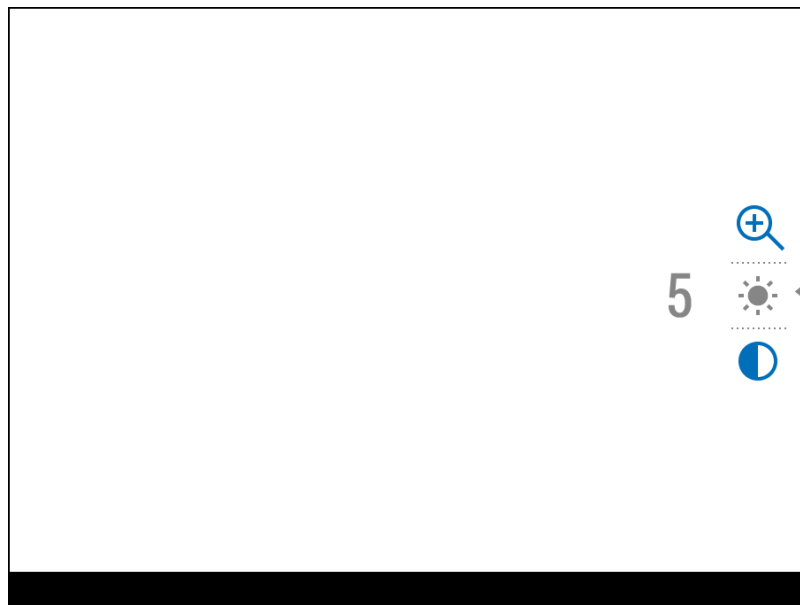

### Brightness



– press **UP (3)/DOWN (5)** buttons to change display brightness from 0 to 20.

### Contrast



– press **UP (3)/DOWN (5)** buttons to change display contrast from 0 to 20.

### Base mode



– it allows you to select one of the three observation modes (Forest, Rocks, Identification) as a base for the User mode.



– information on the actual profile and zeroing distance, at which zeroing was done in this profile (for example, profile A, zeroing distance 100 m). Select zeroing distances with **UP (3)/DOWN (5)** buttons. This option is available when more than one distance is saved.

### Smooth digital zoom



– press **UP (3)/DOWN (5)** buttons to change digital zoom in 0.1x increments.

- Exit the quick menu with a long press of **M (4)** button or wait 10 seconds to exit automatically.

## Main menu



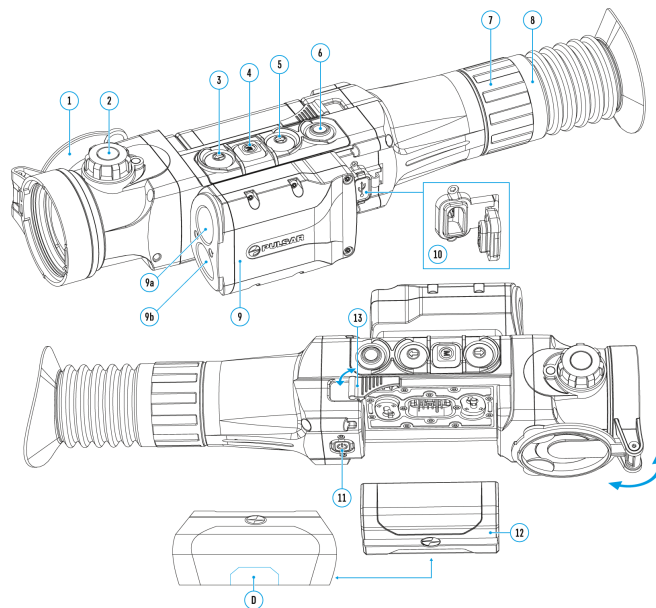





### Enter the Main Menu











1. Enter the main menu with a long press of **M (4)** button.
2. Press **UP (3)/DOWN (5)** buttons to select main menu options.
3. Enter a submenu of the main menu with a short press of **M (4)** button.
4. Exit a submenu with a long press of **M (4)** button.
5. Automatic exit takes place in 10 sec of inactivity.

#### Menu contents:

#### Tab 1

| Menu  | Mode  |
|---|---|
|  | >   |
|  |  |
|  | <input checked="" type="checkbox"/> On  |
|  | >   |
|  | 10  |
|  | <input checked="" type="checkbox"/> On  |
|  | Automatic   |

Tab 2

| Menu  | Microphone                             |
|---|--|
|  | <input checked="" type="checkbox"/> On |
|  | White hot                              |
|  | >                                      |
|  | >                                      |
|  | >                                      |
|  | >                                      |
|  | >                                      |
|  |  |

# Bluetooth

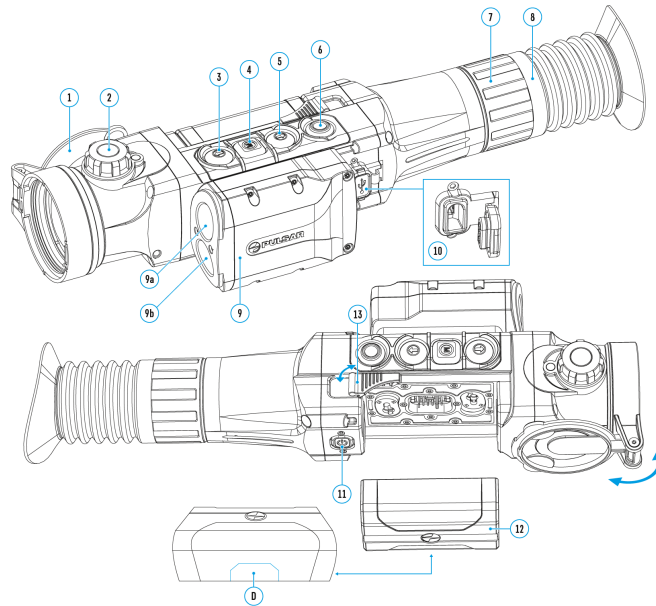

Turn on/off Bluetooth

1. Press and hold the **M (4)** to enter the main menu.
2. Press **UP (3)/DOWN (5)** buttons to select the **Bluetooth**



menu item.

3. A short press of the **M (4)** opens the submenu.
4. Turn Bluetooth on/off with a short press of the **M (4)**.
5. Press and hold down the **M (4)** to exit the submenu.

---

## Bluetooth Pairing with Stream Vision Ballistics App

1. Turn on the Bluetooth module.

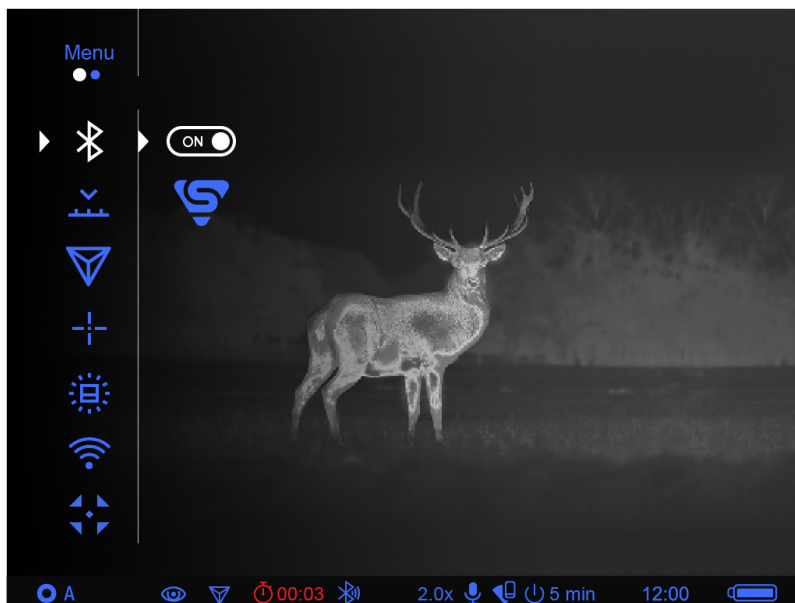

2. In the **Bluetooth**



section of the menu, use the **UP (3)/DOWN (5)** buttons to select the **Bluetooth pairing**



menu item.

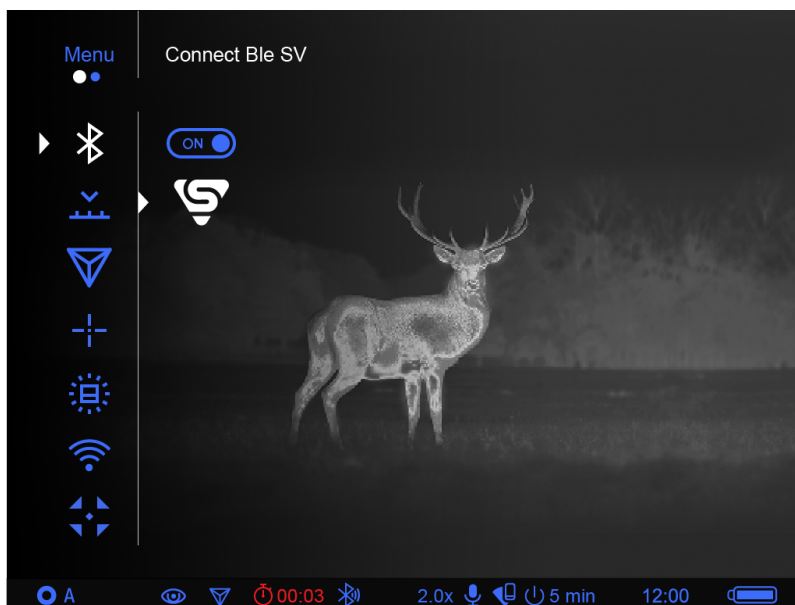

3. Confirm your selection with a short press of the **M (4) button**.

4. Turn on Bluetooth on your smartphone.

5. Connect your smartphone to the riflescope using the **Stream Vision Ballistics App** (Devices tab → Connect Device button).

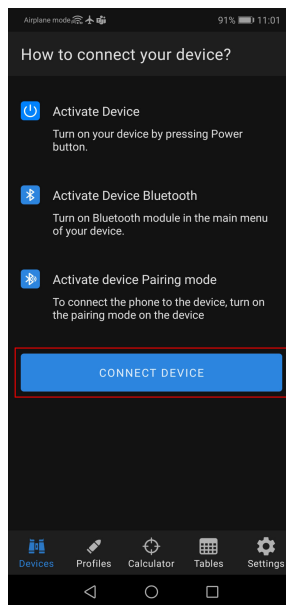

6. Click "Connect" next to your device.

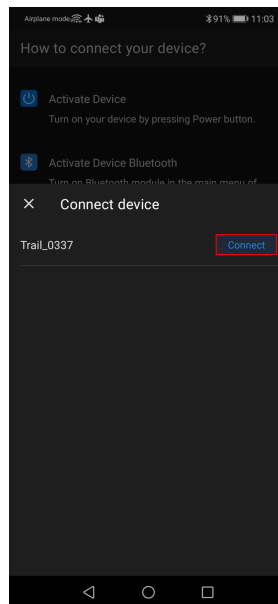

7. Enter the code from the riflescope screen in the Stream Vision Ballistics App and tap "Connect".

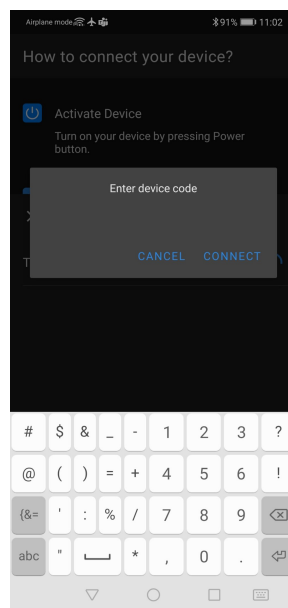
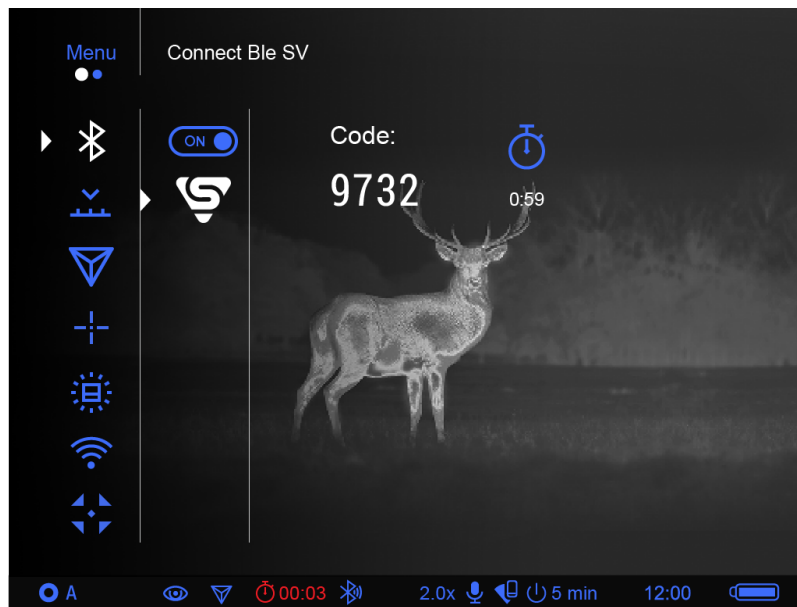

8. The blue Bluetooth icon



next to the riflescope means that the riflescope is connected.

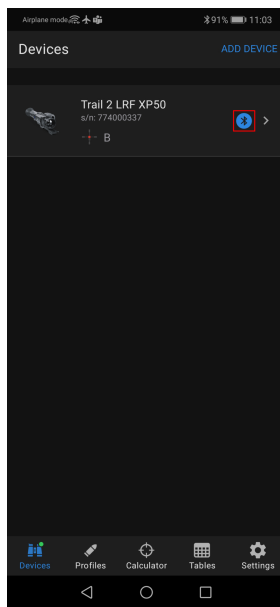

# Mode

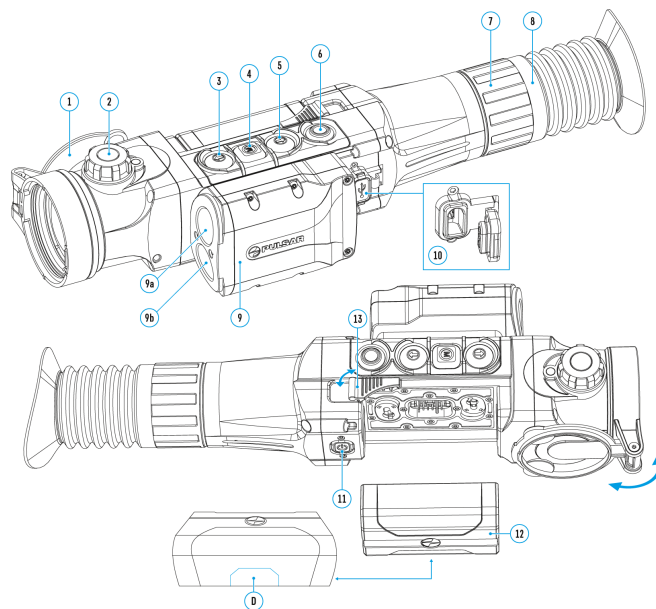

The device has four operating modes of the thermal imager: Forest (observation mode of objects within low thermal contrast conditions), Rocks (observation mode of objects within high thermal contrast conditions), Identification (high detalization mode), User (individual brightness and contrast settings).

1. Enter the main menu with a long press of **M (4)** button.
2. Press **UP (3)/DOWN (5)** buttons to select **Mode**



menu item.

3. Enter the Mode submenu with a short press of **M (4)** button.
4. Select one of the settings described below with **UP (3)/DOWN (5)** buttons.
5. A short press of the **M (4)** button confirms the selection.



## Forest

This is the best mode when searching and observing within field conditions, against the background of leaves, bushes and grass. The mode is highly informative about an object being observed as well as landscape details.



## Rocks

This is the best mode when observing objects after a sunny day or within urban conditions.



## Identification

This is the best mode when observing objects within adverse weather conditions (fog, mist, rain and snow). It allows you to recognize the characteristics of an object being observed more clearly. Zoom increase may be accompanied by insignificant image graininess.



## User

It allows you to configure and save custom brightness and contrast settings, as well as one of the three modes (Forest, Rocks, Identification) as basic.

# Image Detail Boost

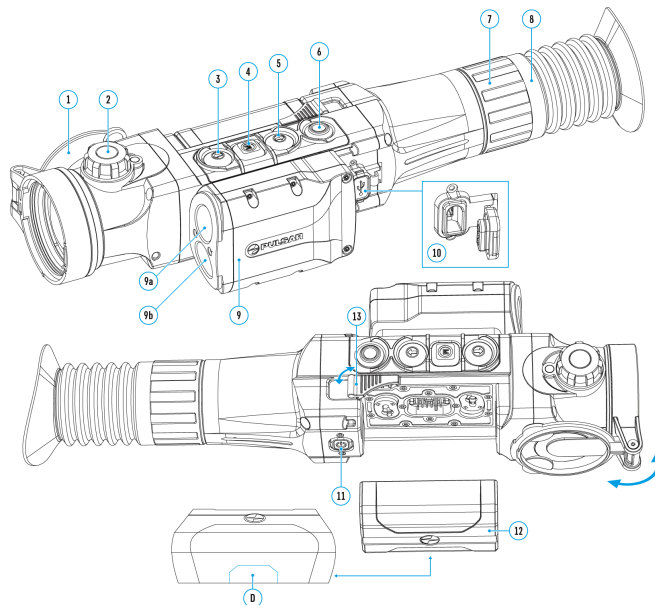

## The Image Detail Boost



function increases sharpness of the contours of heated objects, which increases their detail. The result of the function depends on the selected mode and observation conditions: the higher the contrast of objects, the more noticeable the effect. This option is enabled by default, but can be disabled in the main menu.

Turn on/off **Image Detail Boost**.

1. Enter the main menu with a long press of **M (4)** button.
2. Select the **Image Detail Boost**



menu option with **UP (3)/DOWN (5)** buttons.

3. Turn Image Detail Boost on/off with a short press of **M (4)** button.

# Reticle Setup

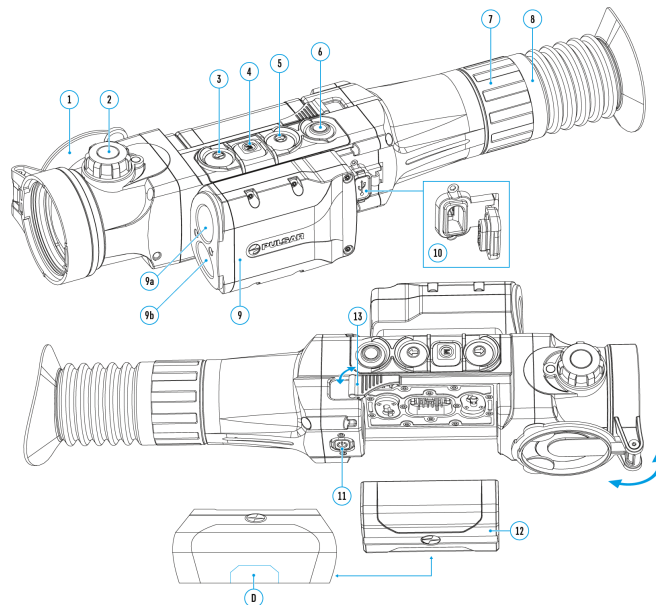

This main menu option allows you to select reticle shape, color and brightness.

1. Press and hold the **M (4)** button to enter the main menu.
2. Press **UP (3)/DOWN (5)** buttons to select the **Reticle Setup**



menu item.

3. Press the **M (4)** button briefly to enter the Reticle Setup submenu.

# Zeroing Profile

This main menu option allows you to select one of ten profiles. Each profile includes the following:

- A set of zeroed distances;
- Reticle color
- Reticle type
- Ballistic profile on/off

Various profiles can be used when employing the riflescope on different rifles and when shooting different cartridges.

Zeroing profiles cannot be deleted. You can change the parameters of zeroing distances or delete distances within a profile.

1. Enter submenu **Zeroing Profile**



with a short press of **M (4)** button.

2. Select one of the zeroing profiles (shown with letters A; B; C; D; E, F, G, H, I, J) with **UP (3)/DOWN (5)** buttons.
3. Confirm your selection with a short press of **M (4)** button.

Name of the selected profile is displayed in the status bar.

## Reticle Type

Selection of reticle shapes.

1. Press **UP (3)/DOWN (5)** buttons to select the **Reticle Type**



menu item.

2. Enter submenu Reticle Type with a short press of **M (4)** button.
3. Select the desired reticle shape with **UP (3)/DOWN (5)** buttons. Reticle type changes as the cursor goes down the reticle list.
4. Confirm your selection with a short press of **M (4)** button.

*Note:* the riflescope supports **scalable reticles**.

## Reticle Color

Selection of reticle color.

1. Press **UP (3)/DOWN (5)** buttons to select **Reticle Color**



menu item.

2. Enter submenu Reticle Color with a short press of **M (4)** button.
3. Select the desired reticle color with **UP (3)/DOWN (5)** buttons.
4. Confirm your selection with a short press of **M (4)** button.

## Reticle Brightness

Reticle brightness setup.

1. Press **UP (3)/DOWN (5)** buttons to select **Reticle Brightness**



menu item.

2. Enter submenu Reticle Brightness with a short press of **M (4)** button.
3. Set desired reticle brightness from 0 to 10 with **UP (3)/DOWN (5)** buttons.
4. Confirm your selection with a short press of **M (4)** button.

## Icon Brightness

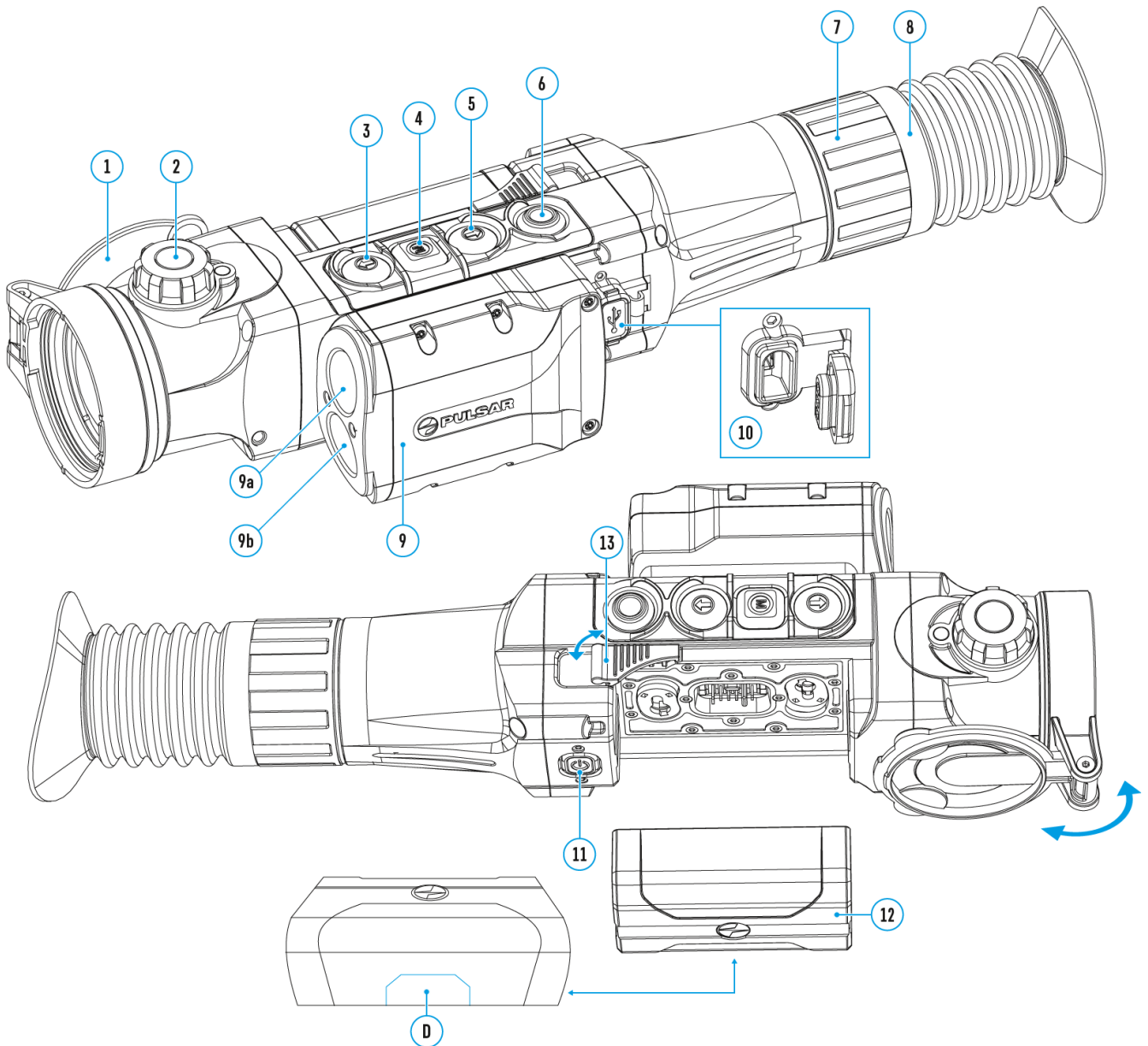

Adjust brightness level of the icons and screensavers (Pulsar, Display off) on the display.

1. Enter the main menu with a long press of **M (4)** button.
2. Press **UP (3)/DOWN (5)** buttons to select **Icon Brightness**



menu item.

3. Enter Icon Brightness submenu with a short press of **M (4)** button.
4. Set desired graphics brightness from 0 to 10 with **UP (3)/DOWN (5)** buttons.
5. Confirm your selection with a short press of the **M (4)** button.

# Wi-Fi Activation

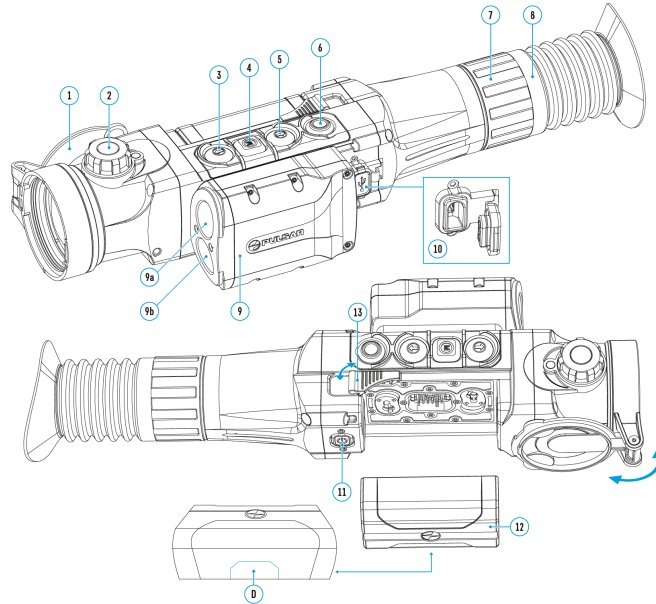

Turn Wi-Fi on/off

1. Enter the main menu with a long press of **M (4)** button.
2. Press **UP (3)/DOWN (5)** buttons to select **Wi-Fi Activation**



menu item.

3. Turn Wi-Fi on/off with a short press of **M (4)** button.

# Calibration Mode

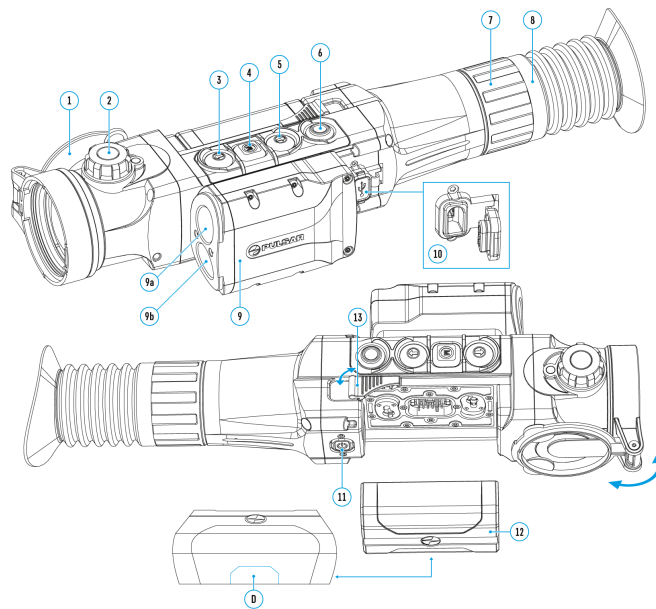

Select calibration mode.

Calibration allows levelling of the background temperature of microbolometer and eliminates image flaws such as frozen image, vertical stripes etc.).

There are three calibration modes: **manual (M)**, **semi-automatic (SA)** and **automatic (A)**.

1. Enter the main menu with a long press of **M (4)** button.
2. Press **UP (3)/DOWN (5)** buttons to select **Calibration Mode**



menu item.

3. Enter Calibration Mode submenu with a short press of **M (4)** button.
4. Select one of the below calibration modes with **UP (3)/DOWN (5)** buttons.
5. Confirm selection with a short press of **M (4)** button.

### Mode M (manual)

- Close lens cover and press **ON/OFF (11)** button briefly.
- Having finished calibration, open the lens cover.

### Mode SA (semi-automatic)

- The user determines for himself the need for calibration based on the actual image status.
- Calibration is activated with a short press of **ON/OFF (11)** button.
- You do not have to close lens cover (microbolometer is closed with internal shutter automatically).

## Mode A (automatic)

- The riflescope calibrates by itself according to the software algorithm.
- You do not have to close lens cover (microbolometer is closed with internal shutter automatically).
- User assisted calibration with **ON/OFF (11)** button is allowed in this mode (as in semi-automatic mode).
- Three seconds before automatic calibration a countdown timer

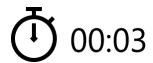

is shown in place of the calibration mode icon.

*Note:* a display image freezes until the calibration is in progress.

## Microphone

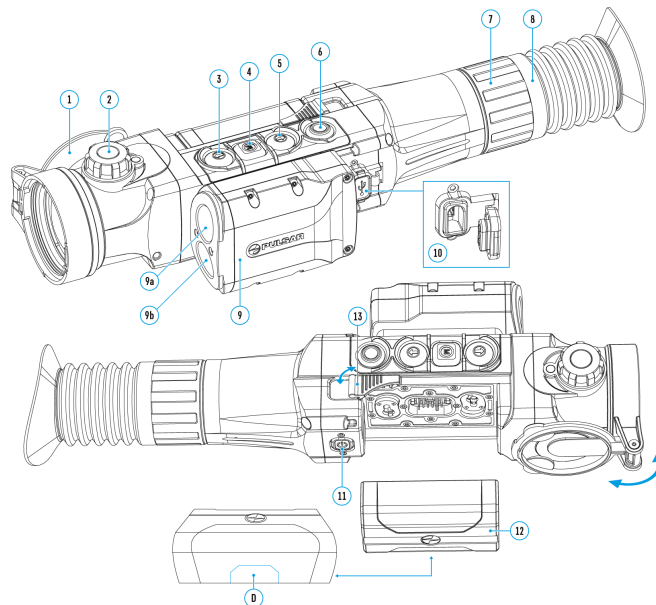

With the microphone on, you will have audio track in your video. Microphone is off by default.

1. Enter the main menu with a long press of **M (4)** button.
2. Press **UP (3)/DOWN (5)** buttons to select **Microphone**



menu item.

3. Turn the microphone on/off with a short press of **M (4)** button

## Color Modes

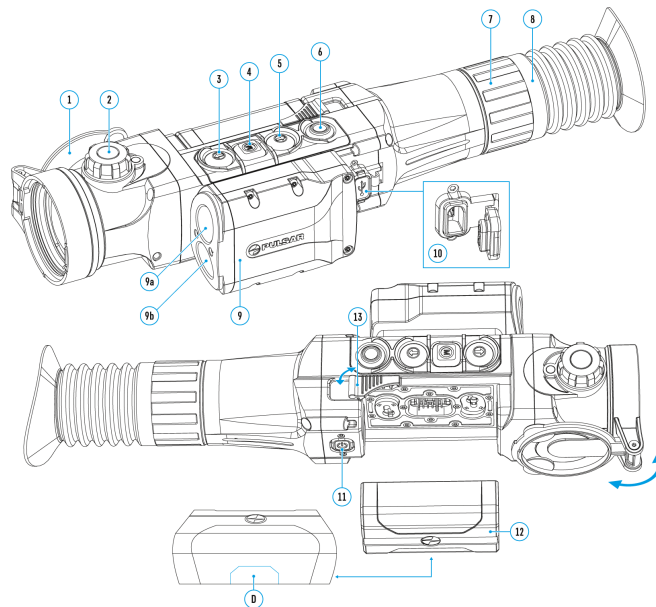

Color mode selection.

**White Hot** is a default display mode for an observed image. The Color Modes menu item allows you to select an alternative palette:

1. Enter the main menu with a long press of **M (4)** button.
2. Press **UP (3)/DOWN (5)** buttons to select **Color Modes**



menu item.

3. Enter submenu Color Modes with a short press of **M (4)** button.
  4. Select one of the palettes described below with the **UP (3)/DOWN (5)** buttons.
  5. A short press of the **M (4)** button confirms the selection.
- **White Hot** – a black and white palette (cold temperature corresponds to black, and hot temperature to white).
  - **Black Hot** – a black and white palette (cold temperature corresponds to white, and hot temperature to black).
  - **Red Hot**
  - **Red Monochrome**
  - **Rainbow**
  - **Ultramarine**
  - **Violet**
  - **Sepia**

**Note:** you can also switch from the mode chosen in the main menu to the White Hot mode with a long press of **UP (3)** button, subsequent long press of **UP (3)** button switches back to the mode chosen in the main menu.

## Rangefinder

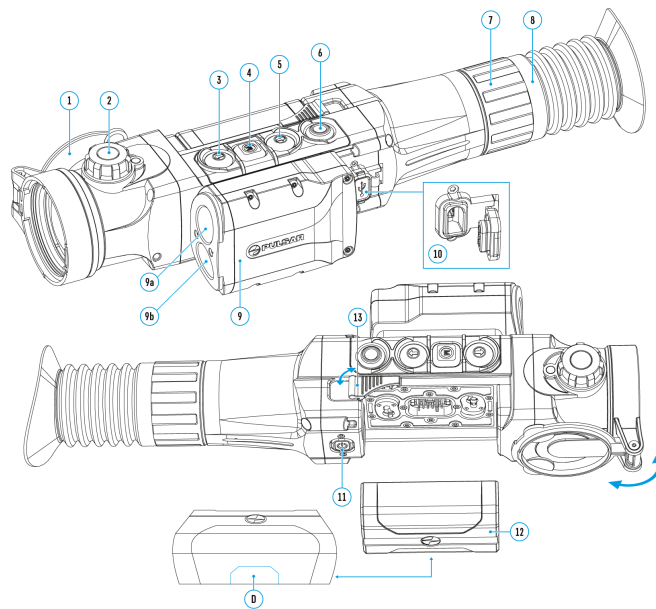

Menu item Rangefinder allows you to set up built-in rangefinder's parameters.

1. Enter the main menu with a long press of the **M (4)** button.
2. Select the submenu **Rangefinder**



with the **UP (3)/DOWN (5)** buttons.

3. Enter the submenu with a short press of the **M (4)** button.
4. Select the desired menu item with the **UP (3)/DOWN (5)** buttons.

## Reticle Type

Selection of rangefinding reticle

1. Select the **Reticle Type**



menu item with the **UP (3)/DOWN (5)** buttons.

2. Press briefly the **M (4)** button to enter submenu.
3. Select one of the three reticle shapes

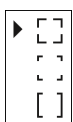

with the **UP (3)/DOWN (5)** buttons.

4. Confirm selection with a brief press of the **M (4)** button.
5. Selected reticle will appear on the display.
6. The reticle will disappear from the display if the rangefinder is not used longer than 4 seconds.

## Target Position Angle

Function Target Position Angle (TPA) allows you to see angle of target location (angle of elevation). When the function is activated, the angle is shown continuously in LRF standby mode in the top right corner of the display.

1. Select **TPA**



with the **UP (3)/DOWN (5)** buttons.

2. Turn **TPA** on/off with a short press of the **M (4)** button.

## True Distance

Function True Horizontal Distance (THD) allows the user to measure true horizontal distance to a target based on the angle of elevation.

1. Select **THD**



with the **UP (3)/DOWN (5)** buttons.

2. Turn **THD** on/off with a short press of the **M (4)** button
3. Hereinafter the message **THD** will appear above the distance readings.

## Auxiliary Indication of Distance

The "Auxiliary indication of distance" function shows an additional window with the result of measuring the distance near the reticles of the rangefinder or ballistic

calculator.

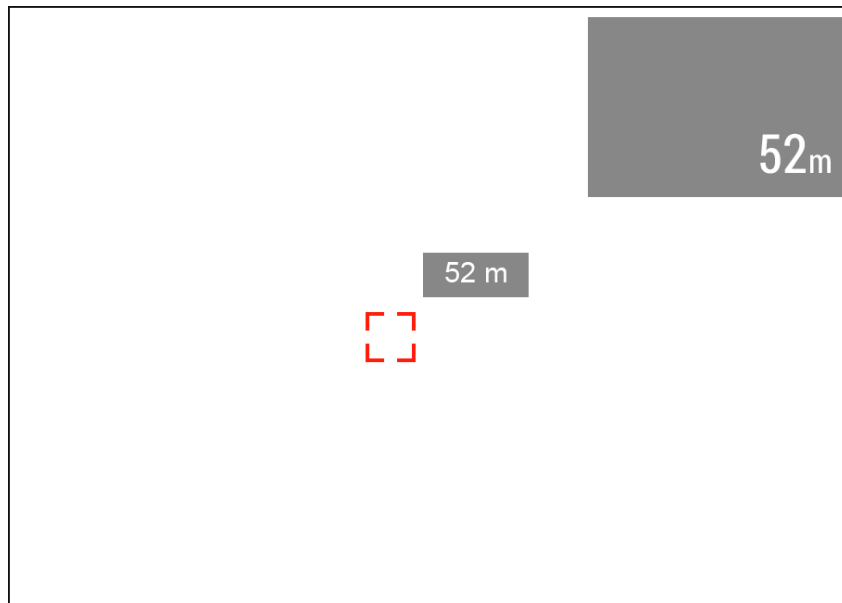

1. Press **UP (3)/DOWN (5)** buttons to select **Auxiliary indication of distance**



2. Press briefly the **M (4)** button to enter submenu.
3. Press **UP (3)/DOWN (5)** buttons to select the display mode: Off, Bound to reticle mark or Bound to SPOA mark.
4. Confirm selection with a brief press of the **M (4)**.

## Ballistic Calculator

The Ballistic calculator function shows the recommended aiming point and correction values. For more information on using the function, see the section **Ballistic Calculator**.

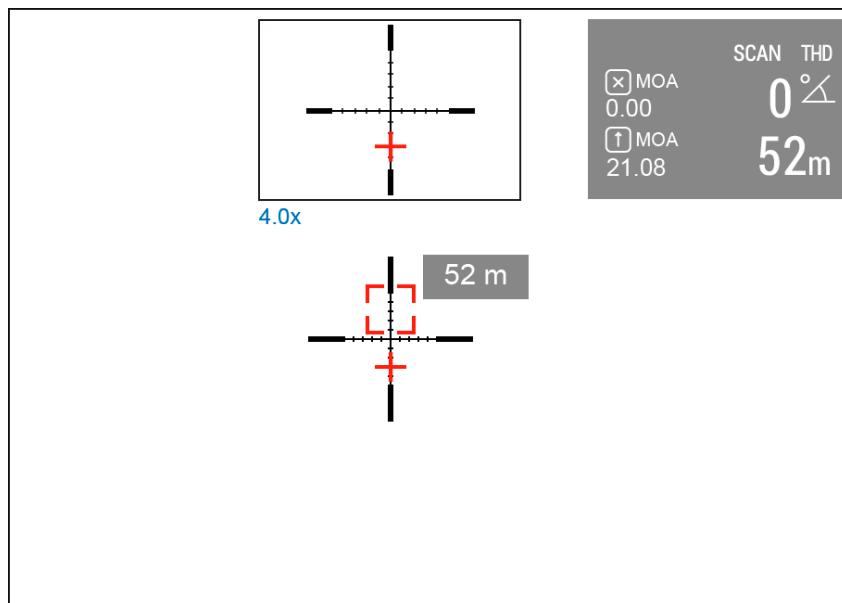

1. Press **UP (3)/DOWN (5)** buttons to select **Ballistic Calculator**



2. Turn the **Ballistic Calculator** on/off with a short press of the **M (4)** button.

## Ballistic Calculator Units

In this item, you can change or disable the units for the ballistic calculator corrections.

1. Press **UP (3)/DOWN (5)** buttons to select the **Ballistic Calculator Units**



menu item.

2. Briefly press the **M (4)** button to enter the submenu.
3. Press **UP (3)/DOWN (5)** buttons to select one of the three units (MOA, mil, Click) or Off to disable the units.
4. Confirm your selection with a brief press of the **M (4)** button.

## General Settings

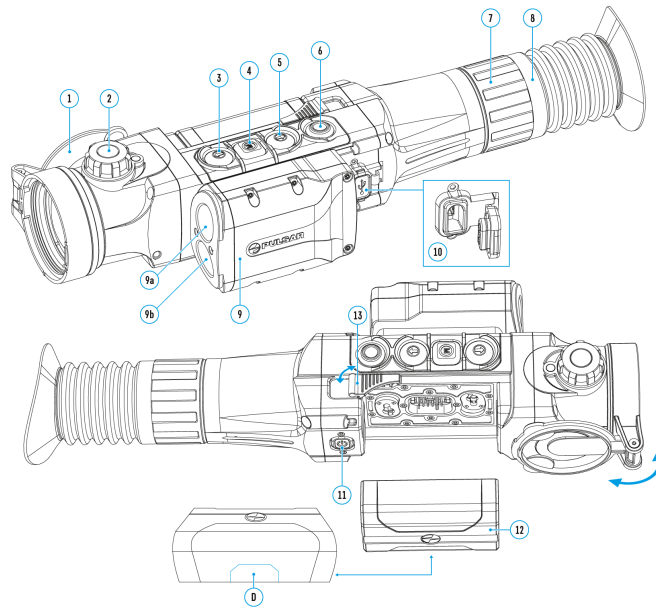

1. Press and hold down the **M (4)** button to enter the main menu.
2. Select option **General Settings**



with the **UP (3)/DOWN (5)** buttons.

3. Press briefly the **M (4)** button to confirm.

The following settings are available:

## Language

Interface language selection.

1. Select option **Language**



with the **UP (3)/DOWN (5)** buttons.

2. Press briefly the **M (4)** button to confirm.
3. Select one of the available interface languages with a short press of the **UP (3)/DOWN (5)** buttons: English, German, Spanish, French, Russian, Italian, Portuguese, Dutch, Danish, Norwegian, Swedish, Polish, Czech, Hungarian.
4. Save selection and exit the submenu with a long press of the **M (4)** button.

# Date

Date setup.

1. Select option **Date**



with **UP (3)/DOWN (5)**.

2. Press briefly the **M (4)** button to confirm. Date format is displayed as: YYYY/MM/DD (year/month/day)
3. Select the correct values for the year, month and date with a short press of the **UP (3)/DOWN (5)** buttons.
4. Switch between digits with a short press of the **M (4)** button.
5. Save selected date and exit the submenu with a long press of the **M (4)** button.

# Time

Time setup.

1. Select option **Time**



with **UP (3)/DOWN (5)** buttons.

2. Press briefly the **M (4)** button to confirm.
3. Select the desired time format with a short press of the **UP (3)/DOWN (5)** buttons: 24 or PM/AM.
4. Switch to hour setup with a brief press of the **M (4)** button.
5. Select hour value with a brief press of the **UP (3)/DOWN (5)** buttons.
6. Switch to minute setup with a brief press of the **M (4)** button.
7. Select minute value with a brief press of the **UP (3)/DOWN (5)** buttons.
8. Save selected time and exit the submenu with a long press of the **M (4)** button.

# Units of Measure

Selection of units of measure.

1. Select option **Units of Measure**



with **UP (3)/DOWN (5)** buttons.

2. Press briefly the **M (4)** button to confirm.
3. Select the desired unit of measurement – meters or yards – with **UP (3)/DOWN (5)** buttons.
4. Press briefly the **M (4)** button to confirm.
5. Exit to general settings submenu takes place automatically.

## Default Settings

Restore default settings.

1. Select option **Default Settings**



with **UP (3)/DOWN (5)** buttons.

2. Press briefly the **M (4)** button to confirm.
3. With a short press of the **UP (3)/DOWN (5)** buttons select "Yes" to restore default settings or "No" to abort.
4. Confirm selection with a brief press of the **M (4)** button.
  - If "Yes" is selected, display will show "Do you want to restore default settings?" and "Yes" and "No" options. Select "Yes" to restore default settings.
  - If "No" is selected, action is aborted and you return to the submenu.

The following settings will be returned to their defaults:

- Image boost – on
- Rangefinder's reticle –



- Reticle selection – M56Fi\*

- Side incline – on
- Wi-Fi – off (default password)
- PiP – off
- Digital zoom – initial optical zoom
- Language – English
- Calibration mode – automatic
- Microphone – off
- Zeroing profile – A
- Operating mode of video recorder – video
- “THD” – on
- Reticle color – black/red\*
- Auto shutdown – off
- Reticle brightness – 10\*
- Observation mode – “Forest”
- “TPA” – on
- Color palette – White Hot
- Units of measurement – meters

\* These values are set for all zeroing profiles (A, B, C, D and E).

**Warning:** date and time settings, default pixel map and all zeroed distances are saved.

## Format

This menu option allows you to format the device’s memory card. All files will be deleted.

1. Select option **Format**



with **UP (3)/DOWN (5)** buttons.

2. Press briefly the **M (4)** button to confirm.
3. With a short press of the **UP (3)/DOWN (5)** buttons select “Yes” to format the memory card or “No” to return to the submenu.
4. Confirm selection with a short press of the **M (4)** button.

- If "Yes" is selected, display will show "Do you want to format memory card?" and "Yes" and "No" options. Select "Yes" to format the memory card.
- If "No" is selected, formatting is aborted and you return to the submenu.

## Wi-Fi Settings

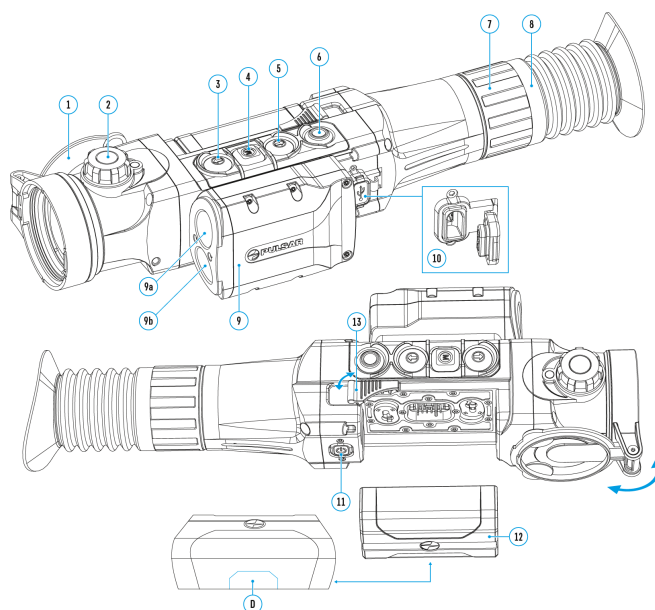

Wi-Fi setup. This menu option allows you to set up your riflescope for operation in a Wi-Fi network.

1. Press and hold down the **M (4)** button to enter the main menu.
2. Select the **Wi-Fi Settings**



menu option with the **UP (3)/DOWN (5)** buttons.

3. Press briefly the **M (4)** button to enter submenu.
4. Select the desired menu item with the **UP (3)/DOWN (5)** buttons.

# Password Setup

This submenu allows you to set a password to access your thermal rifle scope from a mobile device. The password is used to connect a smartphone or a tablet to your thermal rifle scope.

1. Press briefly the **M (4)** button to enter submenu **Password Setup**



2. The default password **(12345678)** will appear on the screen.
3. Set the desired password with the **UP (3)/DOWN (5)** buttons.
4. Switch between digits with a short press of the **M (4)** button.
5. Save the password and exit the submenu with a long press of the **M (4)** button.

# Access Level Setup

This submenu allows you to set access levels of Stream Vision application to your rifle scope.

- Access level **Owner**. The Stream Vision user has the complete access to all device's functions.
- Access level **Guest**. The Stream Vision user has the access only to the real time video stream from the device.

1. Press briefly the **M (4)** button to enter submenu **Access Level Setup**



submenu.

2. Select the access level with the **UP (3)/DOWN (5)** buttons.
3. Press and hold the **M (4)** to confirm your selection and exit from the submenu.

# Side Incline

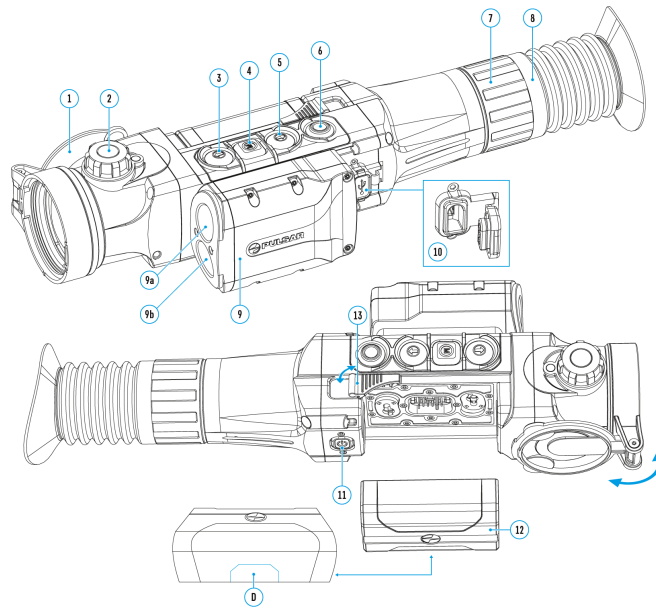

This function indicates horizontal (side) incline of the rifle. Side incline is indicated by "sector" arrows to the right and left of the reticle. Arrows indicate weapon tilt.

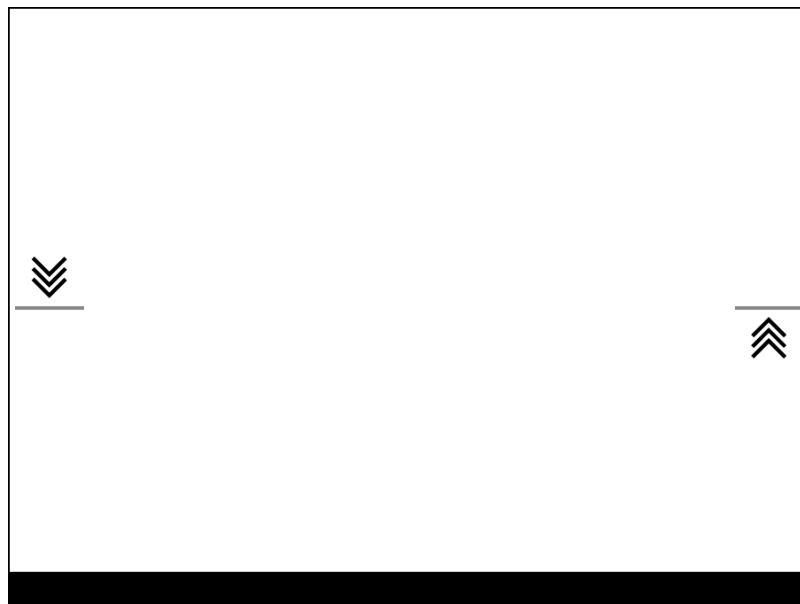

There are three levels of incline:

- 5°-10° – one sector arrow;
- 10°-20° – two sector arrow;
- > 20° – three sector arrow.

A side incline of less than 5° is not displayed.

1. Enter the main menu with a long press of **M (4)** button.
2. Press **UP (3)/DOWN (5)** buttons to select **Accelerometer**

((•))

menu item.

3. Enter submenu Accelerometer with a short press of **M (4)** button.
4. Select submenu **Side Incline**

→←

with **UP (3)/DOWN (5)** buttons.

5. Turn Side Incline on/off with a short press of **M (4)** button.

## Auto Shutdown

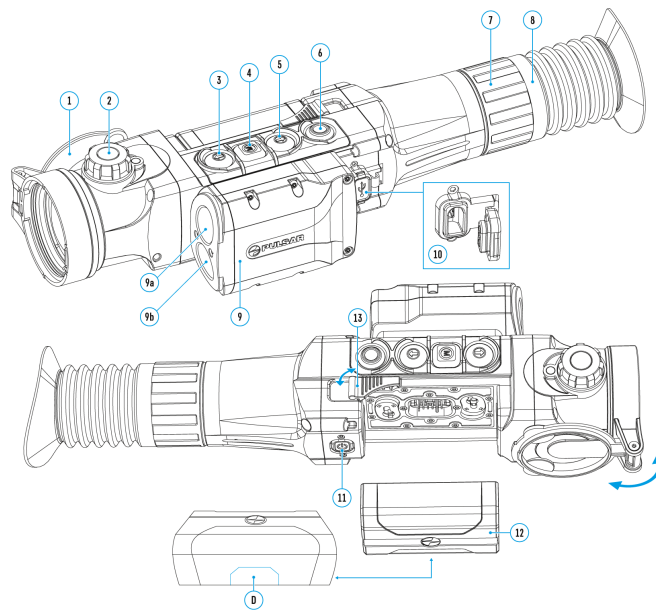

This function allows you to activate auto shutdown of the riflescope in a non-operating position (tilt up or down at an angle of more than 70°, right or left – at an angle of more than 30°).

1. Enter the main menu with a long press of **M (4)** button.
2. Press **UP (3)/DOWN (5)** buttons to select **Accelerometer**

((•))

menu item.

3. Enter submenu Accelerometer with a short press of **M (4)** button.
4. Select submenu **Auto Shutdown**



with **UP (3)/DOWN (5)** buttons.

5. Enter submenu Auto Shutdown with a short press of **M (4)** button.
6. With the **UP (3)/DOWN (5)** buttons select time period (**1 min, 3 min, 5 min**) upon expiry of which the riflescope will automatically shut down. Select **"Off"** if you wish to deactivate Auto Shutdown.
7. Confirm your selection with a short press of **M (4)** button.

**Note:** if Auto Shutdown is active, the status bar shows the respective icon and selected time period as



1/3/5 min.

## Defective Pixel Repair

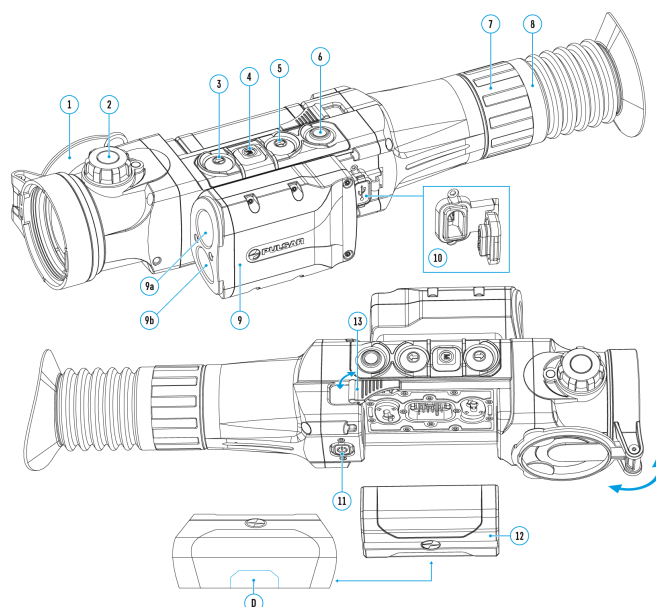

When using the device, defective (dead) pixels may appear on the microbolometer. These are bright or dark points of a constant brightness that are visible on the image.

Defective pixels on the microbolometer can increase in size relatively when digital zoom is activated.

**Trail 2 LRF** thermal riflescopes offer the possibility of removing any defective pixels on the microbolometer using software, as well as to cancel any deletion.

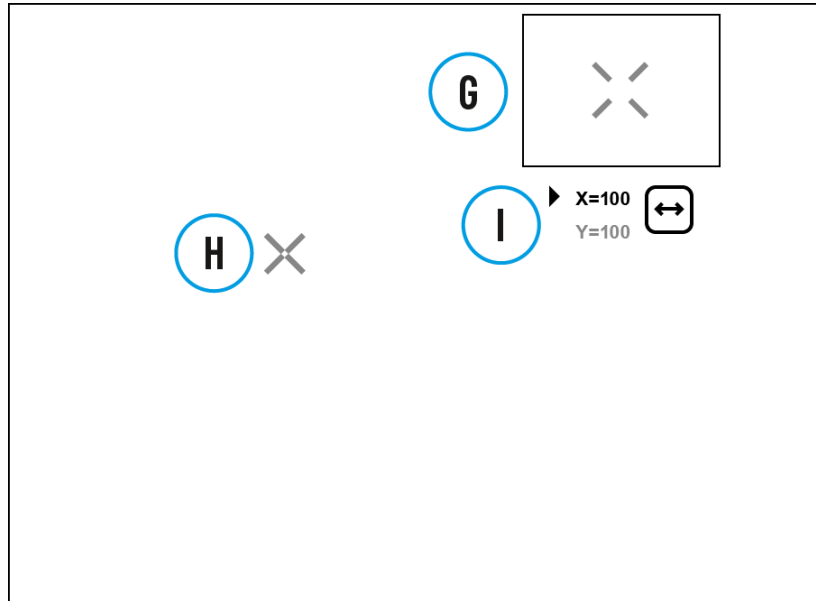

1. Press and hold down the **M (4)** button to enter the main menu.
2. Select the **Defective Pixel Repair**



menu item with the **UP (3)/DOWN (5)** buttons.

3. Press briefly the **M (4)** to open the submenu.
4. Select the **Defective Pixel Repair**



option by briefly pressing the **M (4)** button.

5. A marker **(H)**



appears on the left side of the display.

6. On the right side of the display appears "magnifying glass" **(G)** – a magnified image in a frame with a fixed cross



, designed for easier detection of a defective pixel and to match the pixel with the marker, horizontal and vertical arrows for X and Y axes (**I**) showing marker's movement.

7. With a short press of the **UP (3)/DOWN (5)** buttons move the marker to align it with a defective pixel.
8. Switch the direction of the marker from horizontal to vertical and vice versa with a short press of the **M (4)** button.
9. Align the defective pixel with the fixed cross in the frame – the pixel should disappear.
10. Delete the defective pixel with a brief press of the **ON/OFF (11)** button.
11. A brief message **"OK"** appears in the frame in case of success.
12. Then you can delete another defective pixel by moving the marker along the display.
13. Exit **Defective Pixel Repair** with a long press of the **M (4)** button.

**Attention!** 1-3 pixels on the display of the riflescope in the form of bright white, black or colored (blue, red or green) dots may appear. These points cannot be removed and not a defect.

## Restore Default Pixel Map

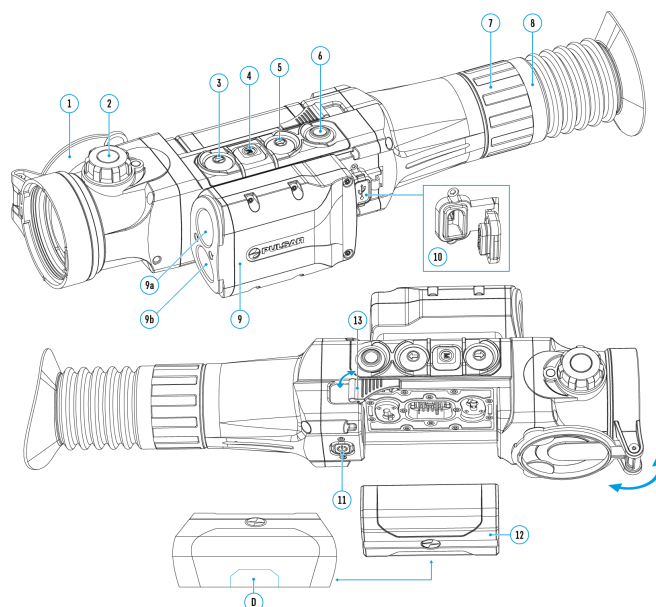

This option allows you to cancel deletion of all defective pixels and return them to the original state.

1. Enter the main menu with a long press of **M (4)** button.
2. Press **UP (3)/DOWN (5)** buttons to select **Defective Pixel Repair**



menu item.

3. Enter submenu with a short press of **M (4)** button.
4. Press **UP (3)/DOWN (5)** buttons to select **Restore Default Pixel Map**



menu item.

5. Press **M (4)** button.
6. Select "Yes" if you wish to return to default defective pixel map, or "No" if you do not.
7. Confirm selection with a short press of **M (4)** button.

## Device Information

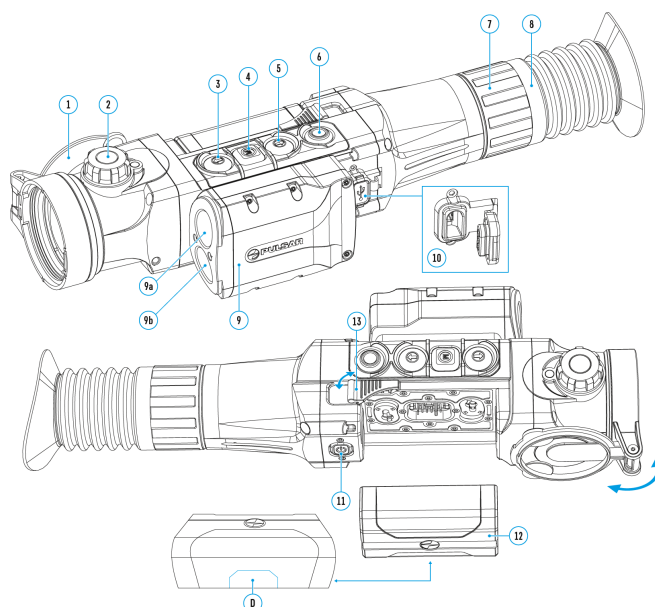

This option allows the user to view the following information about the riflescope:

- Full name
- SKU number
- Serial number
- Software version
- Hardware version
- Service information

To display information, do the following:

1. Press and hold down the **M (4)** button to enter the main menu.
2. Select option **Device Information**



with the **UP (3)/DOWN (5)** buttons.

3. Press briefly the **M (4)** button to confirm.

# Functions

## Video Recording and Photography

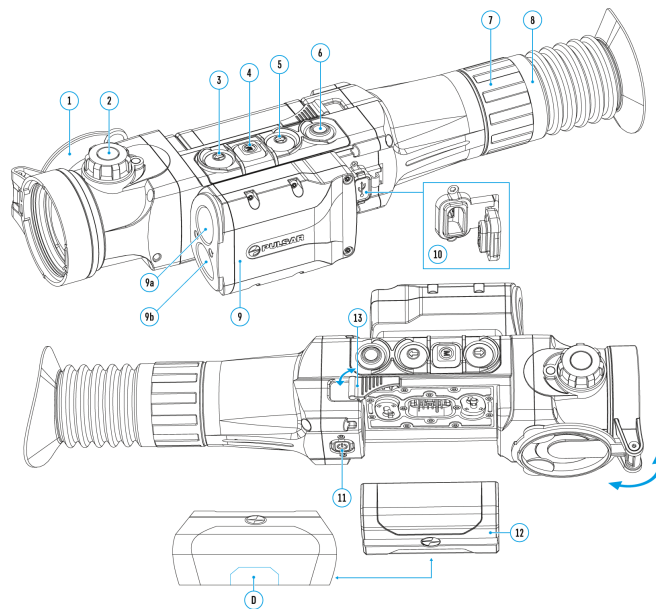

**Trail 2 LRF** thermal riflescopes feature video recording and photography of an image, which are saved to an internal memory card.

Before using this feature, please read the **Date** and **Time** subsections of the section **General Settings**.

The built-in recorder operates in two modes – **Video** and **Photo**.

### Video mode. Video recording



1. Switch to **Video** mode with a long press of **REC (6)** button.
2. In the top left corner you will see icon



and remaining recording time in the format HH:MM (hours: minutes).

3. Start video recording with a short press of **REC (6)** button.
4. Upon start of video recording icon



disappears, and icon REC and recording timer in the format MM:SS (minutes : seconds) appear instead:

●REC | 00:25

5. Pause and resume recording video with a short press of **REC (6)** button.
6. Stop recording video with a long press of the **REC (6)** button.
7. Video files are saved to memory card after stopping the video.
8. Switch between modes (**Video**→ **Photo**→ **Video**) with a long press of **REC (6)** button.

### Photo mode. Capturing an image



1. Switch to **Photo** mode with a long press of **REC (6)** button.
2. Take a picture with a short press of **REC (6)** button. The image freezes for 0.5 sec and a photo is saved to memory card.

### Notes:

- You can enter and operate the menu during video recording.
- Recorded videos and photos are saved to built-in memory card in the format img\_XXX.jpg (photos); video\_XXX.mp4 (videos). XXX – three-digit counter for videos and photos.
- The counter for multimedia files cannot be reset.

### Attention!

- Maximum duration of a recorded file is five minutes. After this time expires a video is recorded into a new file. The number of recorded files is limited by the capacity of unit's internal memory.

- Check regularly free capacity of the internal memory, move recorded footage to other storage media to free up space on the internal memory card.
- When the Display Off function is activated, video recording is paused.

### Important!

To playback video files recorded by thermal imaging devices on macOS based computers, we recommend that you use VLC video player or Elmedia player.

### Download links are shown below:

VLC Video Player

<http://www.videolan.org/vlc/download-macosx.html>

ELMEDIA Video Player

<https://apps.apple.com/us/app/elmedia-multiformat-video/id937759555?mt=12>

## Built-In Laser Rangefinder

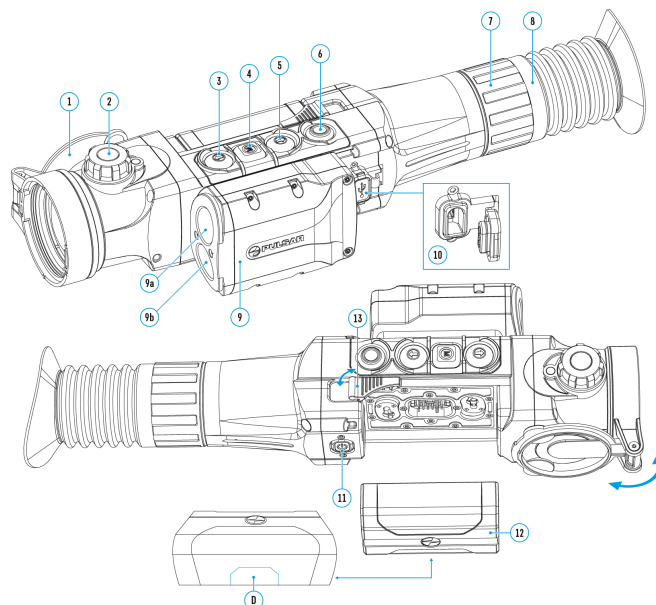

The riflescope is equipped with a built-in rangefinder **(9)**, allowing you to measure distance to objects up to 1000m away.

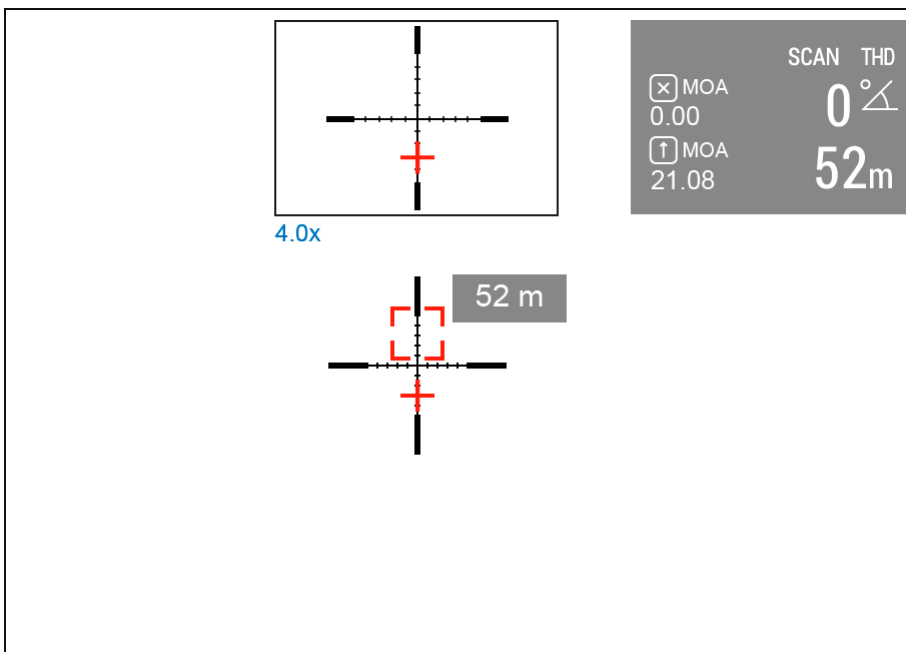

### How the rangefinder works:

1. Turn on the riflescope, adjust image according to section **Powering On and Image Setting**.
2. Press **UP (3)** button — rangefinding reticle appears (and aiming reticle disappears), dashes of distance values with unit of measurement appear in the top right corner of the display , i.e. the rangefinder enters stand-by mode.

----m

3. If PiP mode is on, the aiming reticle disappears upon activation of the rangefinder, but in the PiP window remains active.
4. If PiP mode is off, the activation of the rangefinder automatically turns on the PiP window with the last digital magnification set for it and a reticle in it.
5. Point the rangefinding reticle at an object and press **UP (3)** button.
6. In the top right corner of the display you will see distance in meters (or yards depending on settings).

7m

### Notes:

- If the rangefinder is idle longer than three seconds, it turns off automatically and aiming reticle appears.
- The point of aiming of the rangefinding reticle and the aiming reticle in the PiP window might not coincide due to aiming reticle shift after zeroing.
- To see the recommended aiming point while measuring the distance, activate the **Ballistic Calculator**.

### Operation in SCAN mode:

1. Turn on the rangefinder by briefly pressing the **UP (3)** button.
2. Hold down **UP (3)** button for longer than two seconds. Measurement readings will be changing in real time as you point the riflescope at different objects. In the top right corner a message **SCAN** appears.
3. In case of unsuccessful measurement dashes will appear on the display.
4. To turn off the rangefinder hold the **UP (3)** button.

### Notes:

- To select a rangefinding reticle, please go to submenu **Rangefinder** in the main menu.
- To select units of measurement (meters or yards) go to submenu **General Settings** in the main menu.
- While you measure the distance in the **SCAN** mode you can use the reticle of the PiP window to make a shot.

### Additional Information:

- Accuracy of measurement and maximum range depend on the reflection ratio of the target surface, the angle at which the emitting beam falls on the target surface and environmental conditions. Reflectivity is also affected by surface texture, color, size and shape of the target. A shiny or brightly colored surface is normally more reflective than a dark surface.
- Accuracy of measurement can also be affected by light conditions, fog, haze, rain, snow etc. Ranging performance can degrade in bright conditions or when ranging towards the sun.
- Measuring range to a small sized target is more difficult than to a large sized target.

## Discrete Digital Zoom

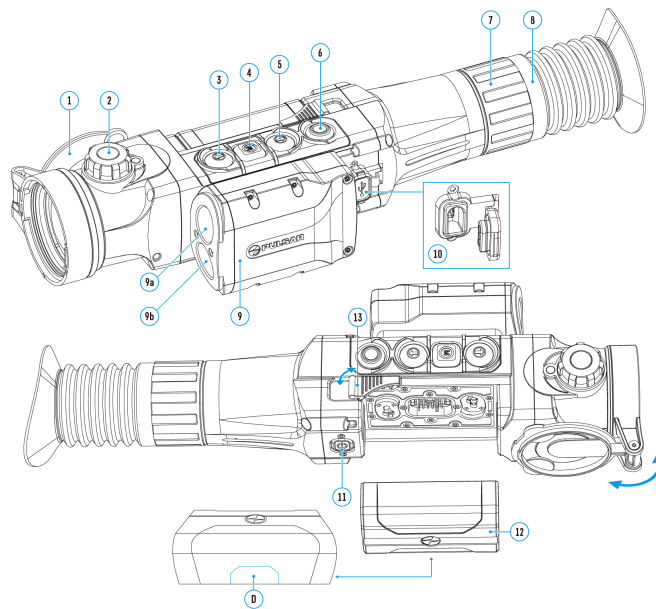

The riflescope allows you to quickly increase base magnification (please refer to **Magnification** line in the **Technical Specifications** table) by two times or four times (8 times in XP models), as well as to return to the base magnification.

To operate the discrete digital zoom, press successively **DOWN (5)** button.

## Ballistic Calculator

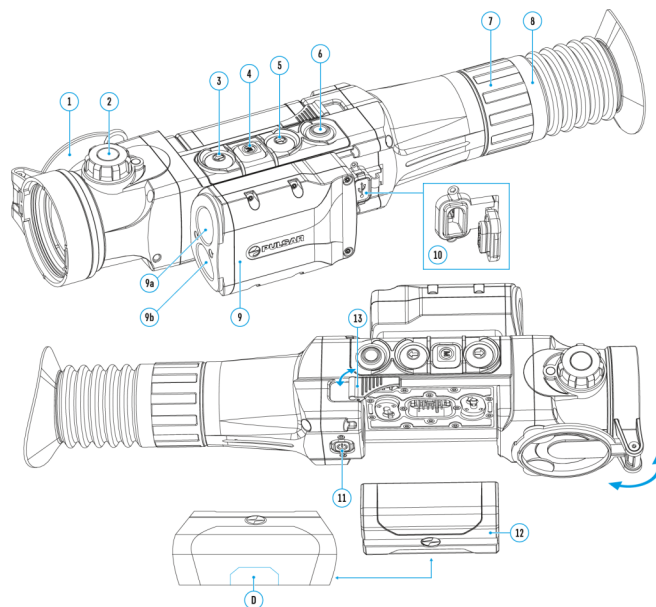

1. Install the Stream Vision Ballistics app from **Google Play** or **AppStore**.

2. Go to Profiles tab.

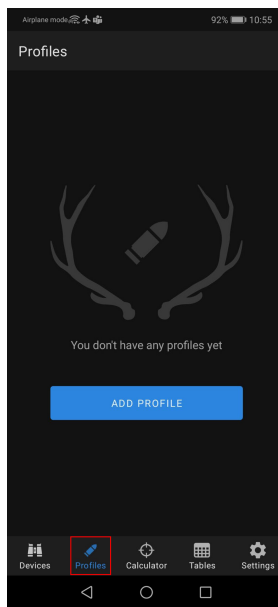

**3.** Create a profile for your riflescope, ammunition and zeroing distance. Make sure that "Ballistic parameters" switch is on. If your ammo is not on the list, you can enter its parameters manually. The more parameters you specify, the more accurate the recommended point of aiming will be.

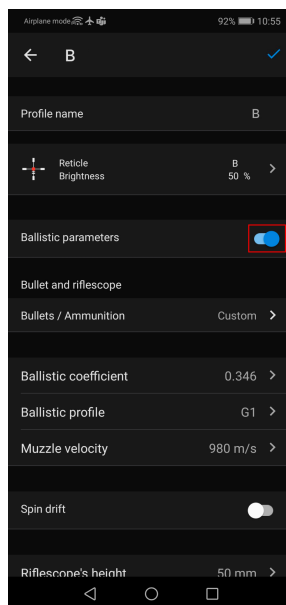

**4.** Adjust the temperature, pressure and humidity of the environment while zeroing your riflescope.

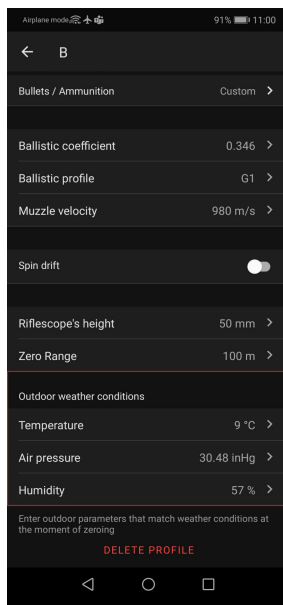

5. Enter a profile name and click save



6. Connect your riflescope to your smartphone using Bluetooth. First, make sure that your riflescope has the latest firmware version 3.0 or higher installed.

7. Load the profile into the riflescope.

To do this, go to the "Devices" tab → Select your riflescope → "All device profiles" → click



on the profile you want to replace and select the created profile from the list.

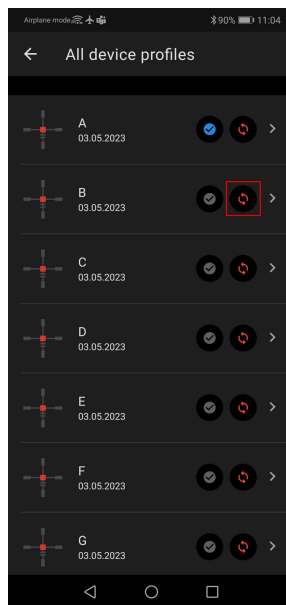

8. Set the status to "Active" for the ballistic profile. To do this, click on the button



next to the desired profile, or select it in the profile selection menu in the riflescope.

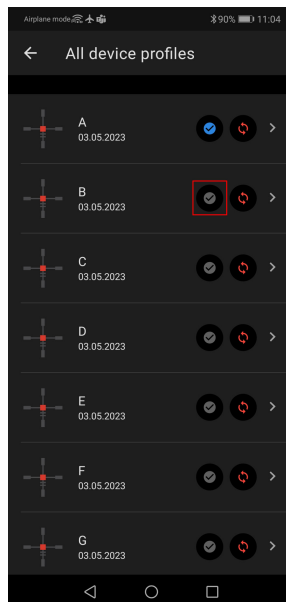

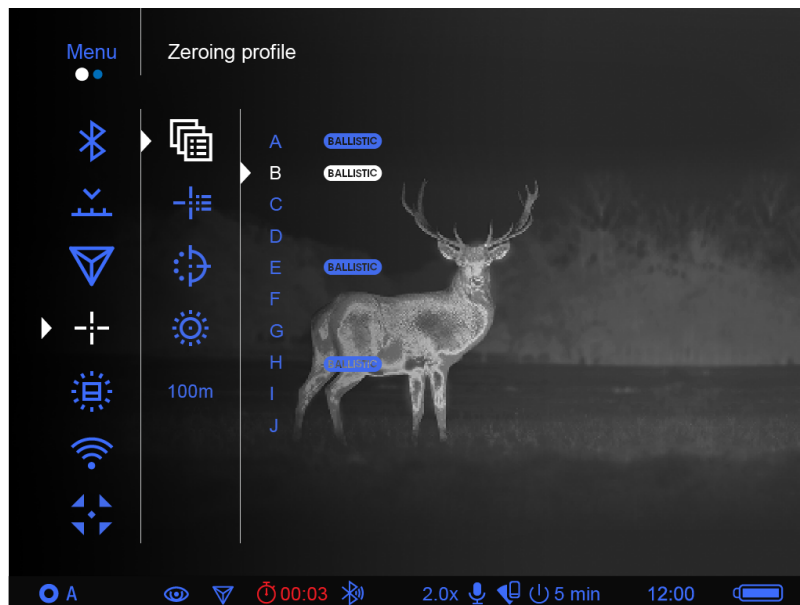

9. Make sure that the Ballistic Calculator



option is enabled in the rifle scope's **rangefinder menu**.

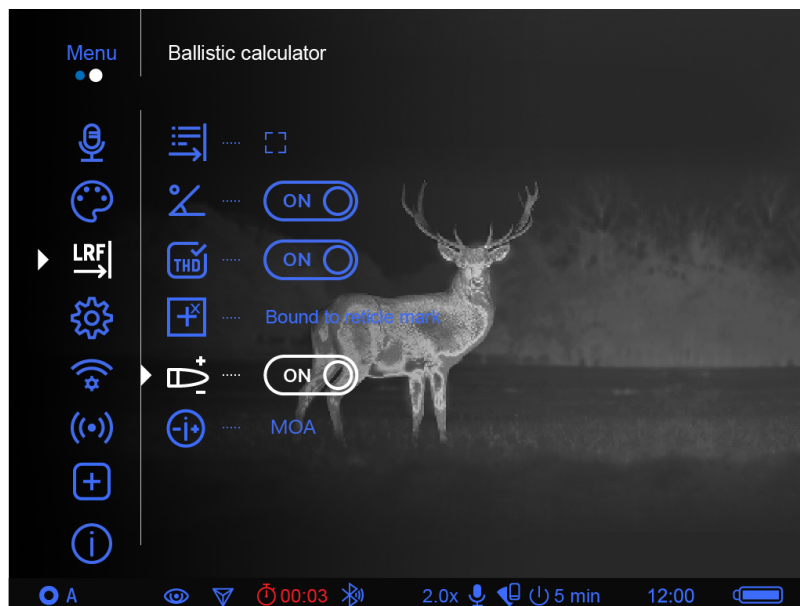

10. Briefly press the **UP (3)** button to activate the rangefinder in the rifle scope.

11. Point the rangefinder reticle at the object and press the **UP (3)** button. The screen will display the recommended aiming point



and correction values in the upper right corner.

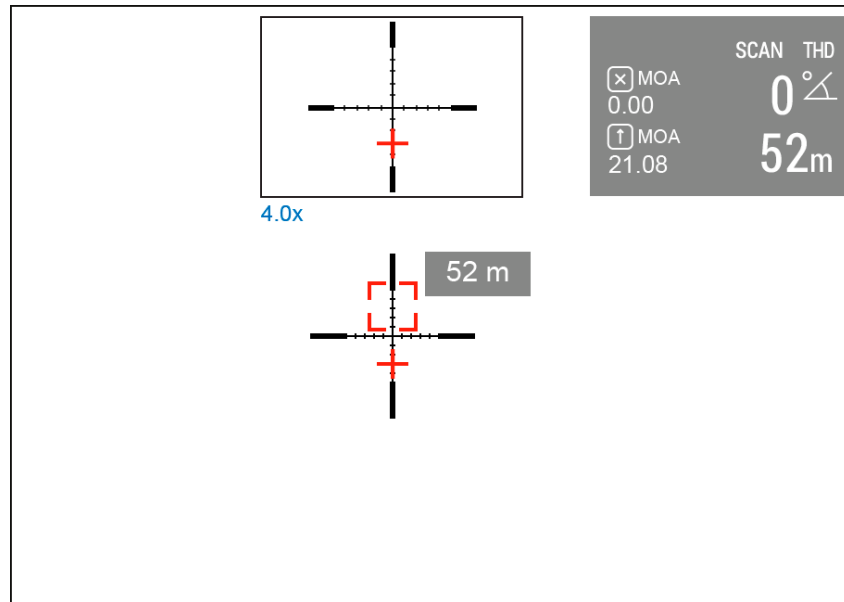

**12.** Check the accuracy of your profile settings with a test shot on the shooting range.

*Note:* profiles for different types of ammunition must be zeroed separately.

**13.** To activate the use of weather data in your geolocation during the shot, go to the "Devices" tab → Select your riflescope → "Set outdoor".

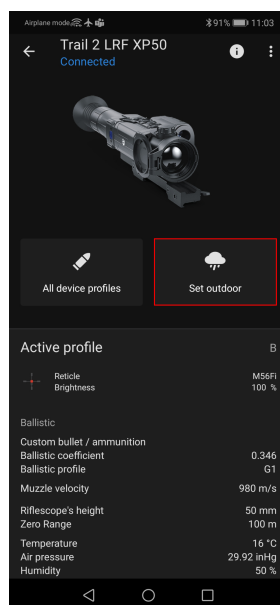

In the **Rangefinder** section of the main menu, you can configure the following settings of the ballistic calculator:

- Screen position of the measured distance value
- Turn on/off the ballistic calculator
- Correction units

## PiP Function

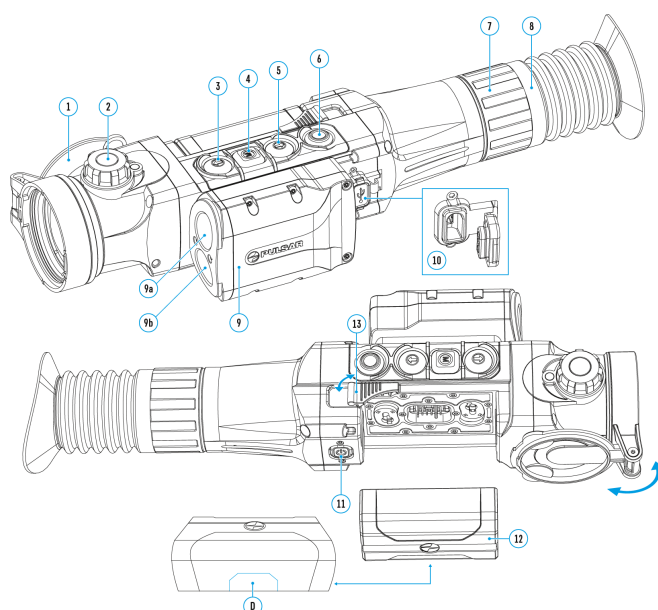

PiP (Picture in Picture) allows you to see a zoomed image in a dedicated window simultaneously with the main image.

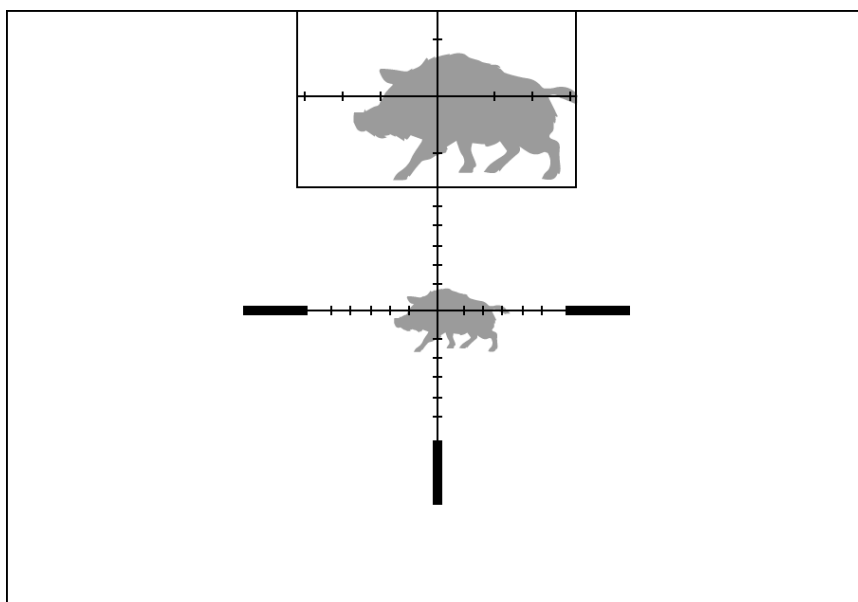

- Turn on/off the PiP function with a long press of **DOWN (5)** button.
- Change zoom ratio in the PiP window with a short press of **DOWN (5)** button.
- The dedicated small window shows zoomed image with magnification value being shown in the bottom left corner of the window.
- The main image is shown with base optical magnification.
- When PiP is turned on, you can operate the discrete and smooth digital zoom. The magnification will take place only in the dedicated window.
- When PiP is turned off, the main image retains the magnification set for the PiP window.

## Display-Off Function

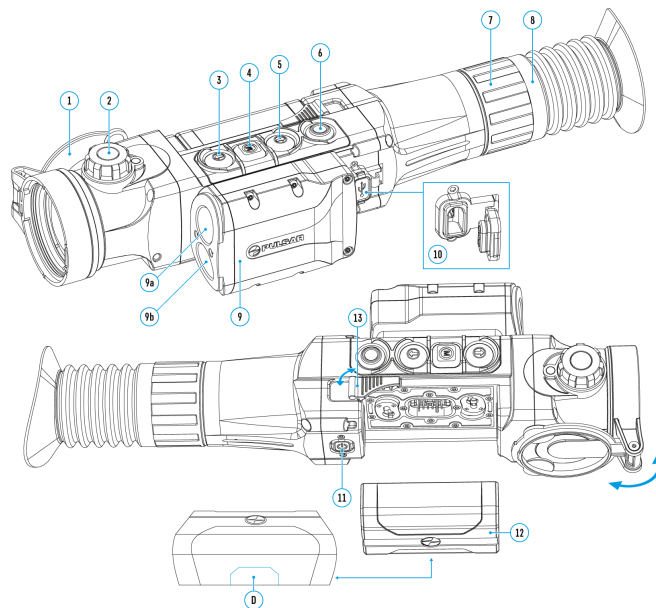

The Display-Off function deactivates transmission of image to the display by minimizing its brightness. This prevents accidental disclosure by light in the dark. In this mode the device is in stand-by and keeps running.

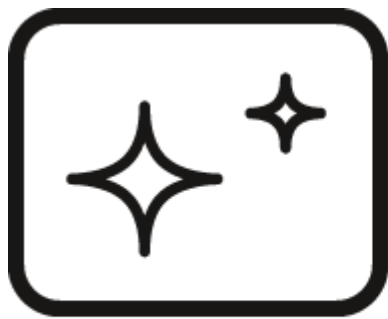

00:03

## Display off

1. To activate the Display-Off function press and hold **ON/OFF (11)** button when the device is switched on. The **"Display off"** message with 3 sec countdown will appear on the screen.
2. Before the end of the countdown release the **ON/OFF (11)** button, otherwise if the countdown ends the device will be switched off.
3. To activate the display, press briefly **ON/OFF (11)** button.

## Wi-Fi Function

Your thermal riflescope features wireless connection option (Wi-Fi) which links it with external appliances (tablet, smartphone).

- Turn on the wireless module as described in the option **Wi-Fi Activation**



Wi-Fi operation is shown in the status bar as follows:

### Connection Status

### Indication in the Status Bar

Wi-Fi is off



Wi-Fi in the riflescope is being activated



Wi-Fi is on, no connection with mobile device



Wi-Fi is on, mobile device connected



- Your riflescope is detected by external appliance as “Trail\_XXXX”, where XXXX — is the last four digits of riflescope’s serial number.
- After entering the password (**default: 12345678**) on a mobile (see the **Password Setup** subsection of the **Wi-Fi Settings** section for more information on setting a password) and setting up a connection, the icon



in the riflescope status bar changes to



## Scalable Reticles

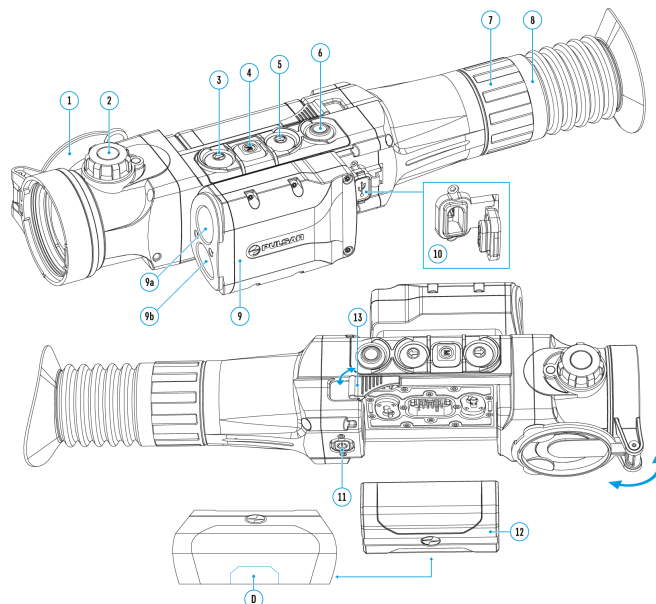

This function is designed to preserve ballistic properties of the scalable reticles for all magnifications.

1. Enter the main menu with a long press of **M (4)** button.
2. Enter submenu **Reticle Setup**



with a short press of **M (4)** button.

3. Enter submenu **Reticle Type**



with a short press of **M (4)** button.

4. Select the reticle (please check available Scalable reticles in the Reticles catalogue in Downloads section on our [web page](#)).

#### **Notes:**

- When zooming in and out the image, the selected reticle on the display and in the recorded video changes its geometrical size according to the magnification selected.
- The reticle scale changes both on the main display and in the PiP mode.

## **USB Connection**

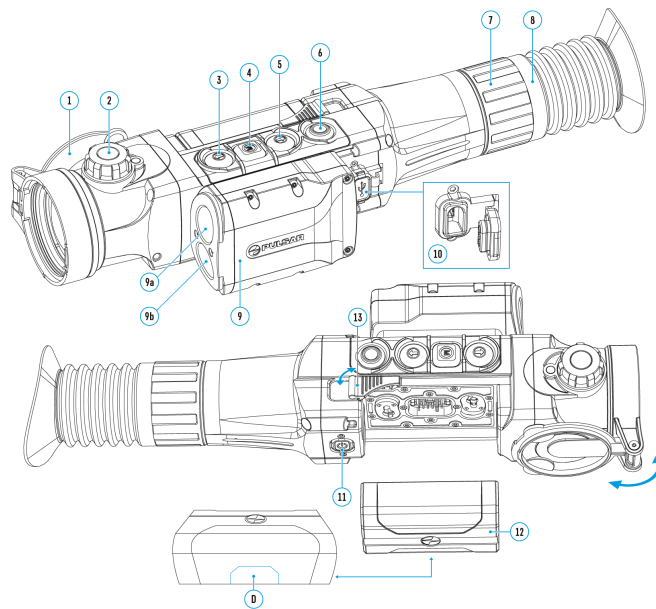

### USB connection



- ▶ Use as power
- Use as memory card

1. Connect one end of the USB cable to the Micro-USB **(10)** port of your riflescope, and the other end to the USB port of your PC/laptop.
2. Turn the riflescope on with a short press of **ON/OFF (11)** button (riflescope that has been turned off cannot be detected by your computer).
3. Your riflescope will be detected by the computer automatically; no drivers need to be installed.
4. Two connection modes will appear on the display: **Power** and **Memory Card (external memory)**.
5. Select connection mode with **UP (3)/DOWN (5)** buttons.
6. Confirm selection with a short press of **M (4)** button.

### Connection modes:

#### Power

- In this mode PC/laptop is used as an external power supply. The status bar shows an icon



. The device continues operating and all functions are available.

- The Battery Pack installed in the device is not being charged!
- When USB cable is disconnected from the device when in the **Power** mode, the device keeps operating with Battery Pack, if available, and it has sufficient charge.

### **Memory card (external memory)**

- In this mode the device is detected by the computer as a flash card. This mode is designed for work with the files saved in device's memory. The device's functions are not available in this mode; the device turns off automatically.
- If video recording was in progress when connection was made, recording stops and video is saved.
- When USB cable is disconnected from the device in **Memory Card** mode, the device remains turned OFF. Turn the device ON for further operation.

# Software

## Firmware Update

### Stream Vision 2

1. Download free Stream Vision 2 App in **Google Play** or **App Store**.
2. Connect your Pulsar device to your mobile device (smartphone or tablet).
3. Launch Stream Vision 2 and go to section "Settings".
4. Select your Pulsar device and press "Check firmware update".
5. Wait for the update to download and install. Pulsar device will reboot and will be ready to operate.

### Important:

- if your Pulsar device is connected to phone, please turn on mobile data transfer (GPRS/3G/4G) to download update;
- if your Pulsar device is not connected to your phone but is already listed in "Settings" > "My devices" section, you may use Wi-Fi to download update.

Find answers to frequently asked questions about using Stream Vision 2 [here](#).

### Stream Vision

1. Download free of charge Stream Vision App on **Google Play** or **App Store**.
2. Connect your Pulsar device to your mobile device (smartphone or tablet).
3. Launch Stream Vision and go to section "My Devices".
4. Select your Pulsar device and press "Check Updates".
5. Wait for the update to download and install. Pulsar device will reboot and will be ready to operate.

### Important:

- if your Pulsar device is connected to phone, please turn on mobile data transfer (GPRS/3G/4G) to download update;
- if your Pulsar device is not connected to your phone but it's already in the "My Devices" section, you may use Wi-Fi to download update.

Find answers to frequently asked questions about using Stream Vision here.

### Is your firmware up to date?

Click [here](#) to check the latest firmware for your device.

## Stream Vision 2



**Trail 2 LRF** support Stream Vision and Stream Vision 2 mobile apps that allow you to stream real-time image from your thermal imager to your smartphone or tablet via Wi-Fi. We recommend using the latest version of Stream Vision 2.

We recommend using the latest version – Stream Vision 2.



Mobile App

# STREAM VISION 2

You can find further guidelines on Stream Vision 2 [here](#).

[Download from Google Play](#)

[Download from App Store](#)

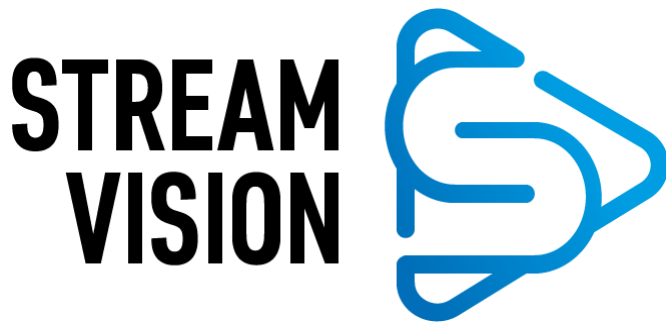

You can find further guidelines on Stream Vision [here](#).

[Download from Google Play](#)

[Download from App Store](#)

# Maintenance

## Maintenance and Storage

Maintenance should be carried out at least twice a year, and should consist of the following measures:

- Wipe the exterior surfaces of metal and plastic parts off dust and dirt with a cotton cloth. To avoid damage to the paint coating, do not use chemically active substances, solvents, etc.
- Clean the electric terminals of the Battery Pack and riflescope's battery slot using a grease-free organic solvent.
- Check lenses of objective, eyepiece and rangefinder. If necessary, remove the particles of dust and sand (preferably without touching the lens). Clean external surfaces of the lenses with means especially designed for the purpose.
- Always store the riflescope in its carrying case in a dry, well-ventilated space. For prolonged storage, remove the batteries.

## Technical Inspection

Check:

- External view (there should be no cracks on the housing).
- The state of the objective, eyepiece and rangefinder lenses (there should be no cracks, spot, dust, deposits etc.).
- The state of the Battery Pack (should be charged) and electric terminals (there should be no oxidation).
- Correct functioning of the controls.



# Troubleshooting

For technical support please contact [support@pulsar-vision.com](mailto:support@pulsar-vision.com).

Answers to frequently asked questions about the devices can also be found in the **FAQ** section.

## The thermal riflescope will not turn on

### **Possible cause**

Battery Pack is discharged.

### **Solution**

Charge the battery.

## Device malfunction

### **Solution**

In case of any malfunctions during operation, try resetting the device by long pressing the ON/OFF button for 10 seconds.

# The riflescope does not operate on external power supply

## **Possible cause**

USB cable is damaged.

## **Solution**

Replace USB cable.

## **Possible cause**

External power supply is discharged.

## **Solution**

Charge the external power supply (if necessary).

# The image is blurry, with vertical stripes and uneven background

## **Possible cause**

Calibration is required.

## **Solution**

Carry out calibration according to section Microbolometer Calibration.

# **Black screen after calibration**

## **Solution**

If the image does not clear after calibration, you need to recalibrate.

**When the device is turned on, the calibration frequency is at first higher, then decreases (if the automatic calibration mode is enabled)**

## **Possible cause**

After turning on the device, it takes some time for the sensor temperature to stabilize. This is normal and is not a defect.

# **The image is too dark**

## **Possible cause**

Brightness or contrast level is too low.

## **Solution**

Adjust brightness/contrast in the Quick Menu.

# **The reticle is blurred and cannot be focused with the diopter knob**

## **Possible cause**

The diopter cannot be adjusted to your eyesight.

## **Solution**

If you wear prescription glasses with a range of +3/-5, keep glasses on when looking through the eyepiece.

# **With a crisp image of the reticle, the image of the observed target that is at least 30 m away is blurred**

## **Possible cause**

Dust and condensate are covering the outside optical surfaces after the riflescope was brought in from the cold into a warm environment, for example.

## **Solution**

Clean the lens surfaces with a blower and soft lens cloth. Let the riflescope dry by leaving it in a warm environment for 4 hours.

### **Possible cause**

The objective lens is not focused.

### **Solution**

Adjust the image by rotating the lens focusing knob.

## **The point of impact shifts after firing rounds**

### **Possible cause**

The riflescope is not mounted securely or the mount was not fixed with thread sealant.

### **Solution**

Check that the riflescope has been securely mounted, make sure that the same type and caliber bullets are being used as when the scope was initially zeroed; if your riflescope was zeroed during the summer, and is now being used in the winter (or the other way round), a small displacement of the point of impact is possible.

## **After zeroing, the aiming reticle moves relative to the centre of the display and the rangefinder reticle**

### **Possible cause**

After shooting, the aiming reticle may not be in the centre of the display. This is normal and is not a defect.

# The riflescope will not focus

## Possible cause

Wrong settings.

## Solution

Adjust the riflescope according to the instructions given in section **Powering On and Image Setting** and check the surfaces of the eyepiece and objective lenses and clean them if necessary from dust, condensation, frost, etc.; to prevent fogging in cold weather, apply a special anti-fog solution.

# Smartphone or tablet cannot be connected to the riflescope

## Possible cause

Password in the riflescope was changed.

## Solution

Delete network and connect again entering the password saved in the riflescope.

## Possible cause

There are too many Wi-Fi networks in the area where the riflescope is located which may cause signal interference.

## Solution

To ensure stable Wi-Fi performance, move the riflescope to an area with few or no Wi-Fi networks.

More information on solving problems with connection by following the links: [Stream Vision FAQ](#), [Stream Vision 2 FAQ](#).

## **No Wi-Fi signal or erratic signal**

### **Possible cause**

The riflescope is beyond reliable Wi-Fi range. There are obstacles between the riflescope and the signal receiver (i.e. concrete walls).

### **Solution**

Place your mobile device in line-of-sight of the Wi-Fi signal.

More information on solving problems with connection by following the links: [Stream Vision FAQ](#), [Stream Vision 2 FAQ](#).

## **There is no image of the observed object**

### **Possible cause**

You are looking through glass.

### **Solution**

Remove glass from the field of view.

# **Poor image quality / Detection range reduced**

## **Possible cause**

Problems described may arise in adverse weather conditions (snow, rain, fog etc.).

# **When using the riflescope at below zero temperatures the image quality is worse than at positive temperatures**

## **Possible cause**

Because of variations in thermal conductivity, observed objects (surrounding environment, background) become warm more quickly at above-zero temperatures, which allows higher temperature contrast and, thus, the quality of the image produced by a thermal imager will be better.

At low operating temperatures, observed objects (background) normally cool down to roughly identical temperatures, which leads to lower temperature contrast, and to image quality (precision) degradation. This is normal for thermal imaging device.

# **Color stripes appear on the display or image disappears**

**Possible cause**

The device has accumulated static charge during operation.

**Solution**

As soon as the impact of the static charge is over, the device may reboot automatically; alternatively please turn off and restart the device.

## **Rangefinder does not measure distance**

**Possible cause**

In front of the receiver lens or emitter lens there is an object that prevents signal transmission.

**Solution**

Make sure that: the lenses are not blocked by your hand or fingers; the lenses are clean.

**Possible cause**

The riflescope is not held steadily when measuring.

**Solution**

Keep the riflescope steady when measuring.

**Possible cause**

Distance to the object exceeds 1000m.

**Solution**

Choose an object at a distance closer than 1000m.

**Possible cause**

Low reflection ratio (i.e. leaves of trees).

**Solution**

Choose an object with a higher reflection ratio.

## **Large measurement error**

**Possible cause**

Inclement weather conditions (rain, mist, snow).

## **The supplied USB cable is broken**

**Solution**

To replace the USB cable, contact your local distributor.

Self-repair of the cable is prohibited.

The ability to use a USB cable from other manufacturers with the device may be limited.

# Legal Compliances and Disclaimers

**Attention! Trail 2 LRF** thermal imaging riflescopes require a license when exported outside your country.

**Electromagnetic compatibility.** This product complies with the requirements of European standard EN 55032: 2015, Class A.

**Caution:** Operating this product in a residential area may cause radio interference.



**Caution:** use of controls of adjustments or performance of procedures other than those specified herein may result in hazardous radiation exposure.

**Updates of the Product.** The manufacturer reserves the right at any time, without mandatory prior notice to the Customer, to make changes to the package contents (subject to the applicable laws, if any), design and characteristics that do not impair the quality of the Product.

**Repair.** Repair of the product is available within 5 years after purchase of the product.

**Limitation of Liability.** Subject to mandatory applicable laws and regulations: manufacturer will not be liable for any claims, actions, suits, proceedings, costs, expenses, damages or liabilities (if any), arising out of the use of this product. Operation and use of the product are the sole responsibility of the Customer. Manufacturer's sole undertaking is limited to providing the product(s) and related services in accordance with the terms and conditions of concluded transactions, including provisions established in warranty. The provision of products sold and services performed by Manufacturer to the Customer shall not be interpreted, construed, or regarded, either expressly or implied, as being for the benefit of or creating any obligation toward any third party (other than Distributor, Dealer, Buyer). Manufacturer's liability hereunder for damages, regardless of the form or action, shall not exceed the fees or other charges paid to Manufacturer for the product(s) and/or service(s).

MANUFACTURER WILL NOT BE LIABLE FOR LOST REVENUES OR INDIRECT, SPECIAL, INCIDENTAL, CONSEQUENTIAL, EXEMPLARY, OR PUNITIVE DAMAGES, EVEN IF THE

MANUFACTURER KNEW OR SHOULD HAVE KNOWN THAT SUCH DAMAGES WERE POSSIBLE AND EVEN IF DIRECT DAMAGES DO NOT SATISFY A REMEDY.

**EAC**

**C €**

