



Proton XQ

Manual

Content

Specifications

Description

Package Contents

Features

Components and Controls

Button Operation

Using the Battery Pack

- Precautions

- Recommendations for Battery Use

- Battery Charging

- Battery Installation

External Power Supply

Operation

- Installing Thermal Imaging Module on the Optical Device

- Installing Pulsar 5x30 B Monocular on to the Proton XQ

- Powering on and Image Setting

Microbolometer Calibration

Status Bar

Quick Menu Functions

Main Menu Functions

- Enter the Main Menu

- Mode

- Image Detail Boost

- Wi-Fi Settings

- General Settings

- Color Modes

- Device Information

- Defective Pixel Repair

 - Defective Pixel Repair

 - Restore Default Pixel Map

- Microphone

- Bluetooth

Calibration Mode

Video Recording and Photography

Wi-Fi Function

Display-Off Function

Wireless Remote Control

Descriptions of Controls

Remote Control Activation

Stream Vision

Firmware Update

USB Connection

Technical Inspection

Technical Maintenance and Storage

Troubleshooting

Legal Compliances and Disclaimers

Specifications

You can learn more about the main parameters [here](#).

XQ30

Model	XQ30
SKU	77378
Microbolometer	
Type	Uncooled
Resolution, Pixels	384x288
Pixel Pitch, μm	17
Frame Rate, Hz	50
Optical Characteristics	
Monocular magnification, x	5
Recommended daylight optics magnification, x	1.5-4
Lens	F30/1.2
Digital Zoom, x	-
Eye Relief, mm/inch	18 / 0.7
Eye Relief Diameter, mm/inch	6 / 0.24
Field-of-view (Horizontal), deg/m per 100 m	12.4 / 21.8
Eyepiece Focusing Range, Diopter	+5/-5
Detection Range (animal height 1.7 m), m/y	900 / 984.25

Minimum Observation Distance, m/y	15 / 16.4
Display	
Type	AMOLED
Resolution, Pixels	1024x768
Operational Characteristics	
Power Supply, V	3-4.2
Battery type/Capacity/Rated Output Voltage	Li-Ion Battery Pack APS 5 / 4900 mAh / DC 3.7 V
External Power Supply	5 V (USB Type-C)
Max. Battery Pack Life (at t = 22 °C), hours*	6
Degree of protection IP code (IEC60529)	IPX7
Operating temperature, °C	-25 ... +50
Overall Dimensions, mm/inch	248x59x75 / 9.76x2.32x2.95
Weight (without battery), kg/oz	0.47 / 16.58
Video Recorder	
Photo/Video Resolution, Pixels	864x648
Video/Photo Format	.mp4 / .jpg
Built-in Memory	16 GB
Built-in memory capacity	About 5 hours of video or more than 100 000 photos
Wi-Fi Channel**	
Frequency	2.4 GHz
Standard	802.11 b/g

*Actual operating time will depend to what extent the Wi-Fi and built-in video recorder is used.

**The reception range may vary depending on various factors: obstacles, other Wi-Fi networks.

Description

The **Proton XQ30** thermal imager is designed for a variety of applications, including hunting surveillance, security activities, day and night photo and video shooting.

The **Proton XQ30** thermal imaging module can be mounted (using the correct PSP Ring Adapter) on to the objective lens housing of various daylight optical devices, converting them into a highly-sensitive thermal imaging device.

To get started, see the sections:

[**Battery Charging**](#)

[**Battery Installation**](#)

[**Installing Thermal Imaging Module on the Optical Device**](#)

[**Installing Pulsar 5x30 B Monocular on to the Proton XQ**](#)

[**Powering on and Image Setting**](#)

[**Stream Vision**](#)

Package Contents

- Proton XQ30 Thermal Imager
- Pulsar 5x30 B Monocular
- Carrying Case
- Wireless Remote Control
- APS 5 Rechargeable Battery
- 2x Lock-cover for APS 5 Battery
- Power Adapter
- USB Type-C Cable with USB Type-A Adapter
- Quick Start Guide
- Lens-Cleaning Cloth
- Warranty Card
- Single-point neck strap

Features

- Microbolometer with a resolution of 384x288 pixels
- Microbolometer pixel size of 17 microns
- 1024x768 AMOLED display resolution
- Compact size
- Easily converts daylight optical devices into thermal imaging devices
- Preserves the benefits of daylight optics in night-time conditions
- Three calibration modes (manual, semi-automatic and automatic)
- Four observation modes: Forest, Rocks, Identification, User
- Detection distance up to 900 m
- Wireless remote control
- Instant start
- Display off function
- Built-in video recording
- Remote firmware update
- Fully watertight (IPX7 protection class)
- Wide operating temperature range (-25 °C - +50°C)
- All-metal body made of light-alloy metal

Video/audio Recording

- Built-in video recorder
- Integration with iOS and Android devices
- Wi-Fi Smartphone remote control and surveillance

Battery Pack

- Quick-change APS 5 Li-ion battery pack
- USB Power Bank charging option



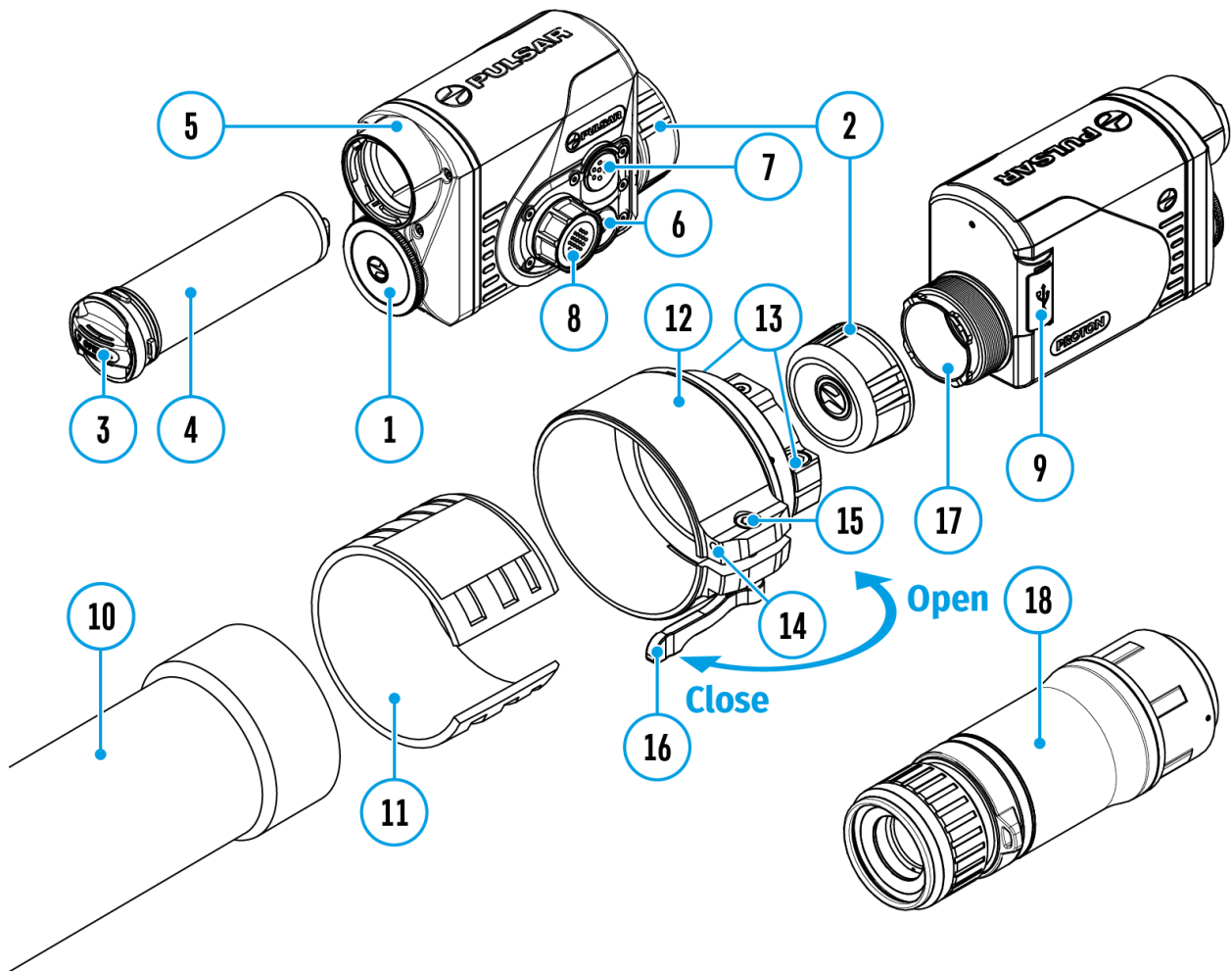













Components and Controls



1. Lens cover
2. Eyepiece cover
3. Battery compartment cover
4. Battery pack
5. Battery compartment
6. ON/OFF button
7. REC button
8. Controller
9. USB port
10. Objective lens end of daylight optical device
11. Insert

12. Adapter
13. Screws
14. Tightening screw
15. Screw
16. Adapter lever
17. Mounting area
18. Pulsar 5x30 B Monocular

Button Operation

Operation	Button
Power device on	 short press
Power device off	 long press for 3 secs
Turn display off	 long press for less than 3 secs
Turn display on	 short press
Calibrate the microbolometer	 short press
VideoRecorder	Button
Start/pause/resume video recording	 short press
Stop video recording	 long press
Switch to video / photo mode	 long press
Capture Photo	 short press
Main Menu	Button
Enter main menu	 long press
Navigation through menu	 rotation
Enter menu items	 short press
Confirm value	 short press
Exit menu items	 long press
Exit main menu	 long press
Quick Menu	Button
Enter quick menu	 short press
Switch between quick menu options	 short press

Parameter change

⊙ rotation

Exit quick menu

⊙ long press

Precautions

- Always use the APS 5 charger supplied with the device (or purchased separately) to charge APS 5 batteries. Using an unsuitable charger can cause irreparable damage to the battery and fire.
- Do not charge the battery immediately after bringing it from cold to warm. Wait at least 30 minutes for the battery to warm up.
- Do not leave the battery unattended while charging.
- Do not use the charger if it has been modified or damaged.
- Do not leave the battery in a charger connected to the mains after charging is complete.
- Do not expose the battery to high temperatures or naked flames.
- Do not use the battery as a power source for devices that do not support APS 5 batteries.
- Do not disassemble or deform the battery or charger.
- Do not drop or strike the battery or charger.
- The battery and charger must not be immersed in water.
- Keep the battery out of the reach of children.

Recommendations for Battery Use

- The batteries should be partially charged (50 to 80 %) for long-term storage.
- The battery is to be charged at an ambient temperature of 0 °C to +35 °C or the lifespan of the battery will decrease significantly.
- When using the battery at sub-zero ambient temperatures, the battery capacity decreases. This is normal and not a defect.
- Do not use the battery at temperatures outside the range of -25°C to +50 °C or it may reduce battery life.
- The battery is short circuit protected. However, any situation that may cause short-circuiting should be avoided.

Battery Charging

The **Proton XQ30** thermal imager comes with an APS 5 rechargeable Lithium-ion battery. APS 5 batteries support USB Power Delivery fast charging technology when using a standard charging set (charger, USB Type-C cable, power adapter). Before first use, make sure the battery is fully charged.

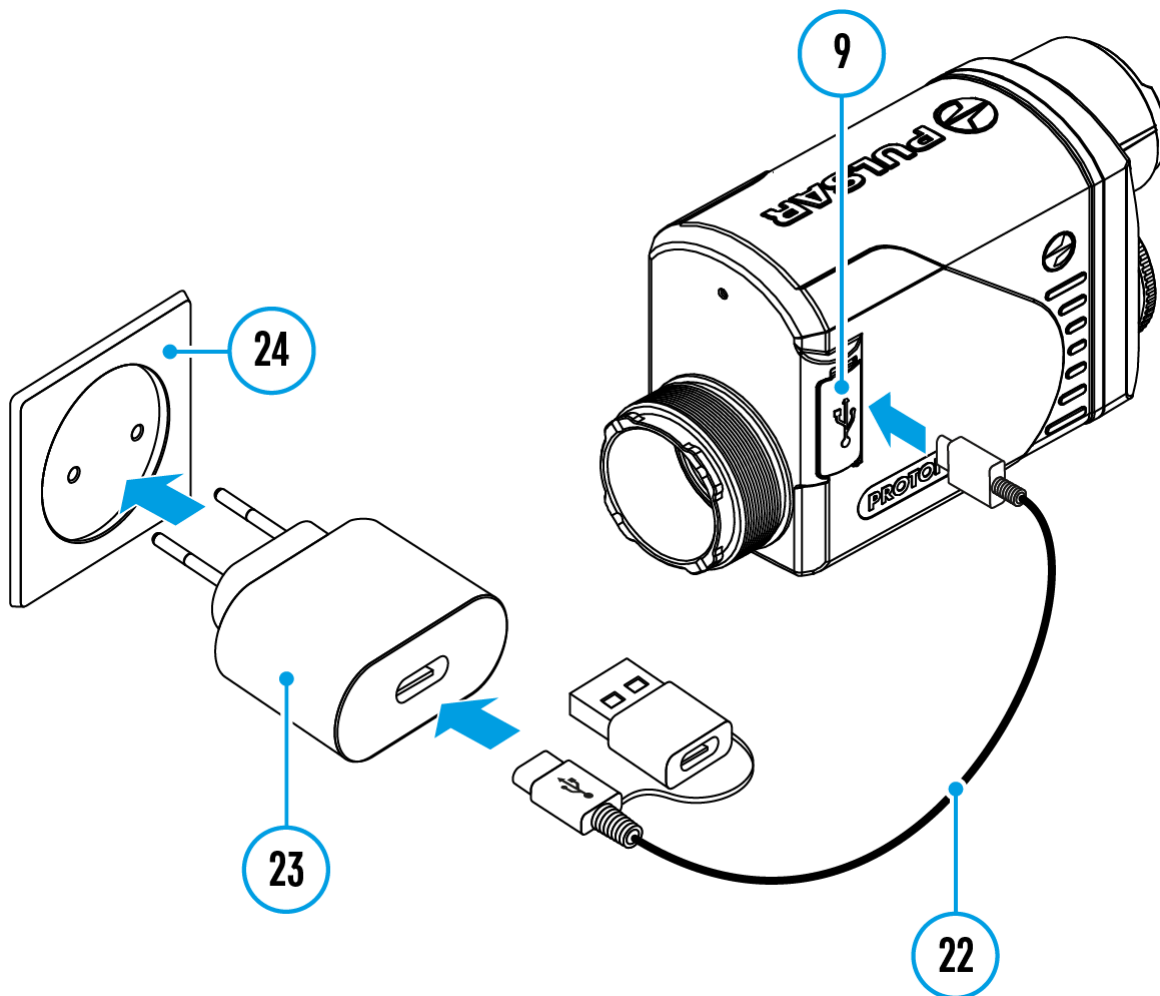

Option 1

1. Install the APS 5 battery **(4)** in the battery compartment **(5)** of the device.
2. Connect the USB cable **(22)** to the USB Type-C connector **(9)** of the

device.

3. Connect the other end of the USB cable **(22)** to the Power Adapter **(23)** by removing the USB Type-A adapter.
4. Plug the Power Adapter **(23)** into a 100-240 V socket **(24)**.

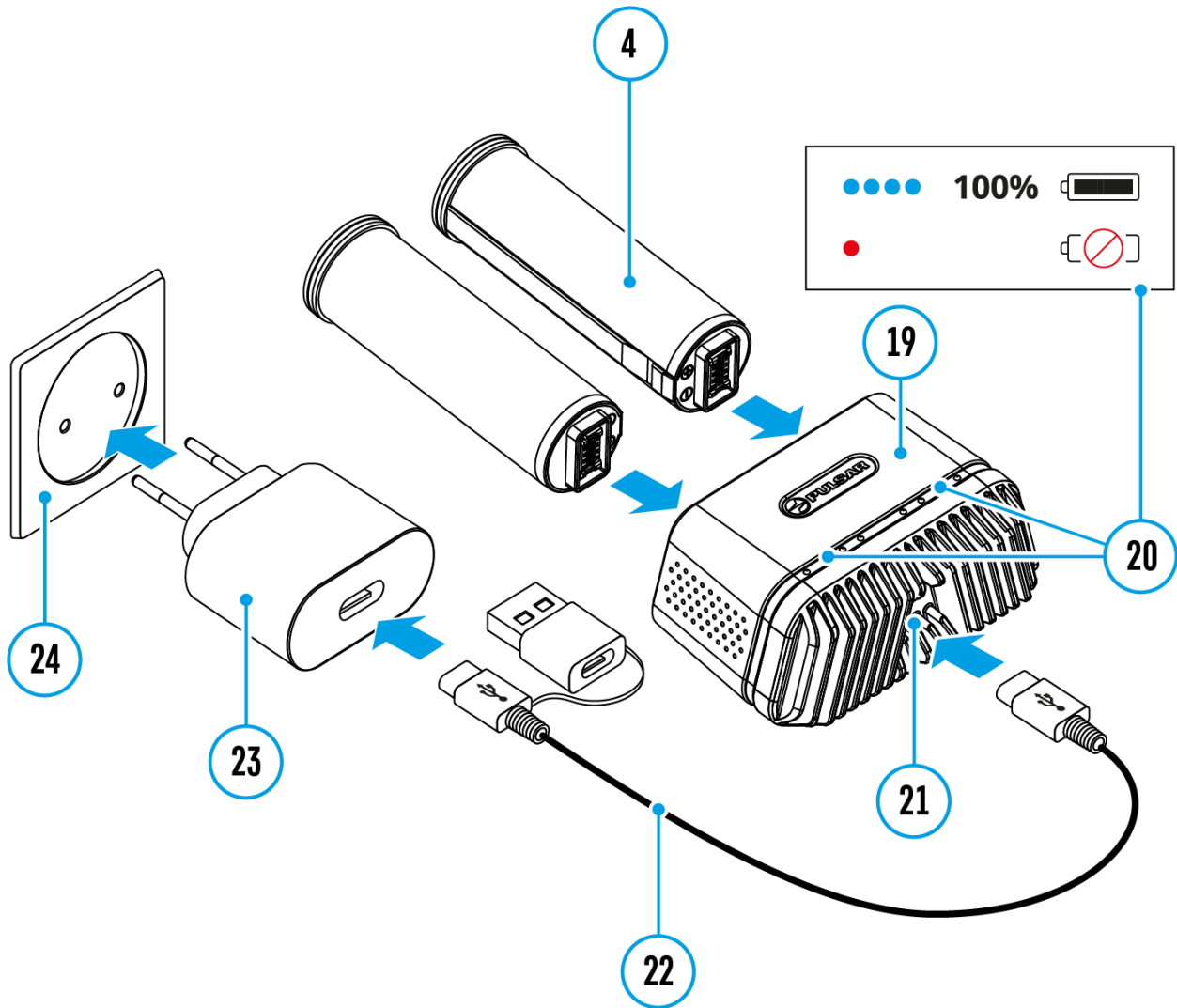











Option 2

1. Insert the APS 5 battery **(4)** along the guide into the APS 5 charger* **(19)** slot as far as it will go.
2. Connect the plug of the USB Type-C cable **(22)** to the USB Type-C connector of the Power Adapter **(21)** by removing the USB Type-A adapter.
3. Plug the Power Adapter **(23)** into a 100-240 V socket **(24)**.
4. Connect the other end of the USB Type-C cable **(22)** to the USB Type-C connector **(21)** of the charger.

5. LED indicators **(20)** will display the battery charge level (see Table).

Note:Two* batteries can be charged at the same time.

LED indication (20) in the battery charging mode	Battery Level
	Battery charge level is from 0% to 25%
	Battery charge level is from 26% to 50%
	Battery charge level is from 51% to 80%
	Battery charge level is from 81% to 99%
	Battery completely charged. Charging will automatically stop. The battery can be disconnected from the charger.
	Defective battery. Do not use the battery!
LED indication (20) in the standby mode**	Battery Level
	Battery charge level is from 0% to 25%
	Battery charge level is from 26% to 50%
	Battery charge level is from 51% to 80%
	Battery charge level is from 81% to 99%



Battery is fully charged. It can be disconnected from the charger.



Defective battery. **Do not use the battery!**

* Sold separately.

** Standby mode is when the batteries are in the charger but the Power Adapter is not connected. In this mode, the indicators are only on for 10 seconds.

Attention! When using a Power Adapter that does not support USB Power Delivery fast charging technology, the flicker frequency of the LED indicators decreases by a factor of 3 and the charge time increases.

Attention! The charger heats up during fast charging. Excess heat is removed through the radiator and does not affect the device operation.

Battery Installation

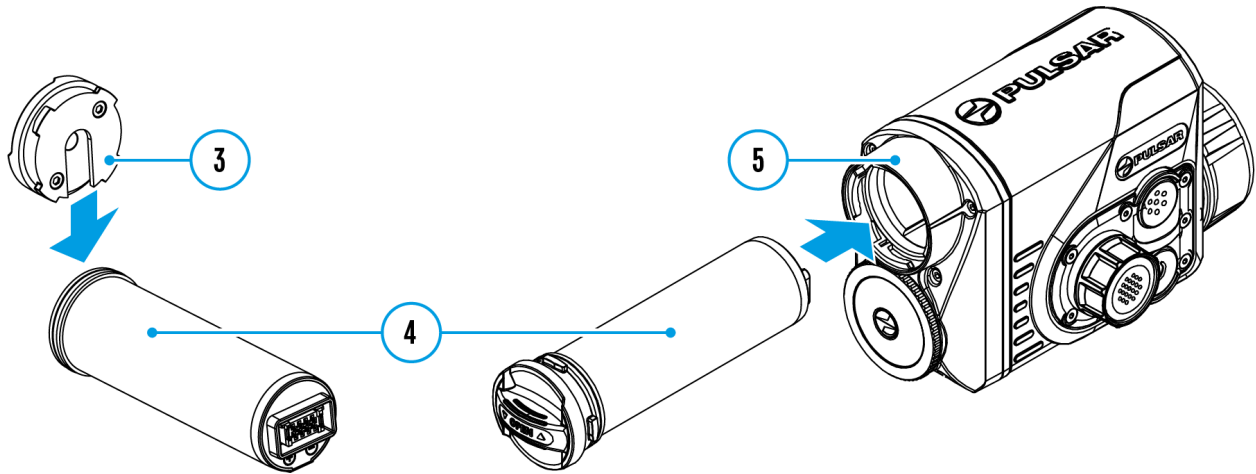

Attention! Before installing the battery, make sure that there is an undamaged rubber insulating ring on the battery. The ring is designed to protect your device from moisture getting inside. Damage to the device due to a missing ring is not covered by the warranty. To replace or purchase a ring, contact your **local distributor**.



1. Put the Lock-cover **(3)** on the rechargeable APS 5 battery **(4)**.
2. Insert the APS 5 battery **(4)** along the guide into the battery compartment **(5)**.
3. Lock the battery **(4)** by turning the Lock-cover **(3)** clockwise until it stops.
4. Turn the Lock-cover **(3)** counter-clockwise to remove the battery **(4)**.

External Power Supply

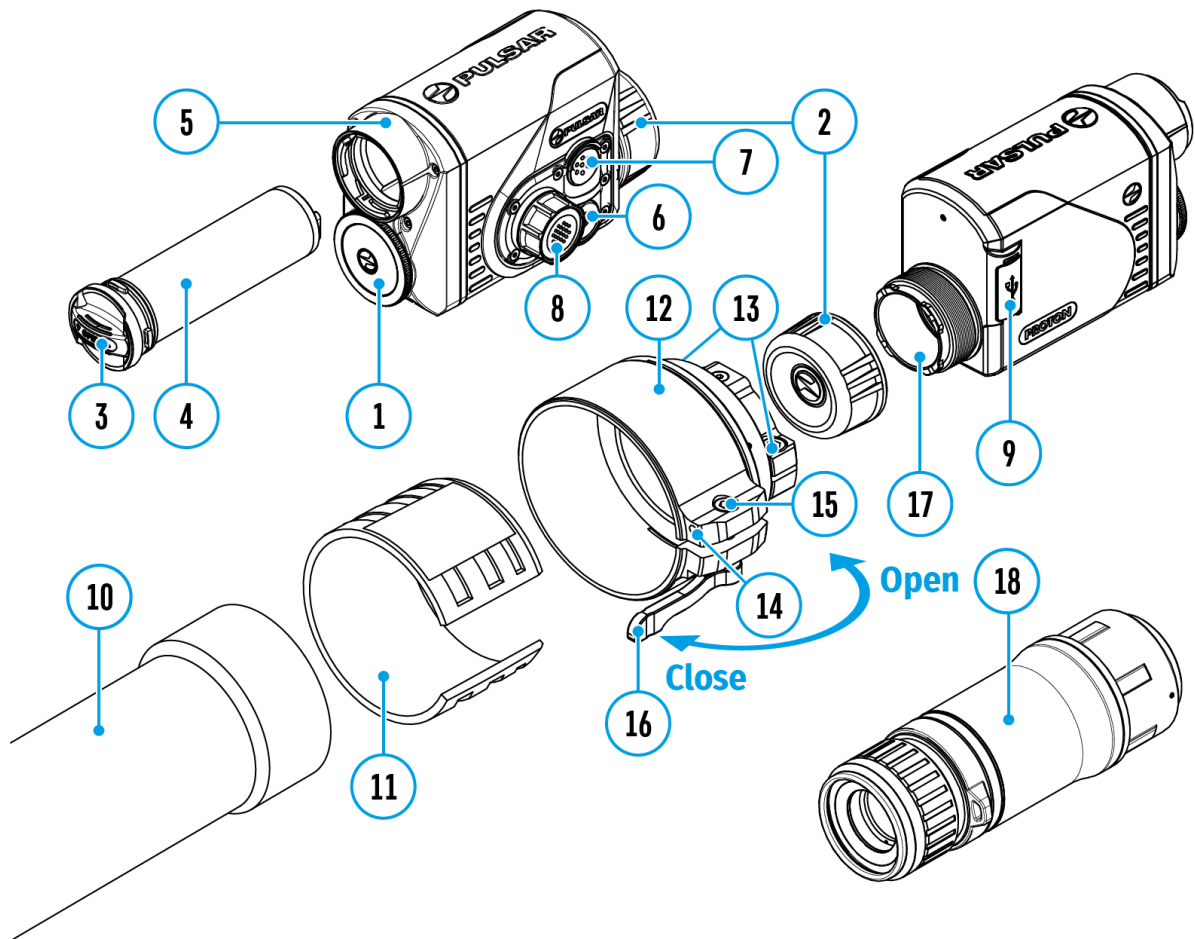
Show device diagram



External power can be supplied from an external source, such as a Power Bank (5 V).

1. Connect the external power source to the USB Type-C connector(9) on the device.
2. The device will switch to draw power from the external source while the APS5 battery will be gradually recharged.
3. A battery icon  will appear on the display showing the percentage charge level.
4. An icon  will be displayed when the device is powered by an external power source and the APS5 battery is not connected.

5. The device automatically switches to the APS 5 battery when the external power supply is disconnected.

Attention! Charging APS 5 batteries from an external source at temperatures below 0°C can reduce battery life. When using external power, connect the Power Bank to the device only after it has been turned on and working for at least several minutes.

Installing Thermal Imaging Module on the Optical Device

Show device diagram

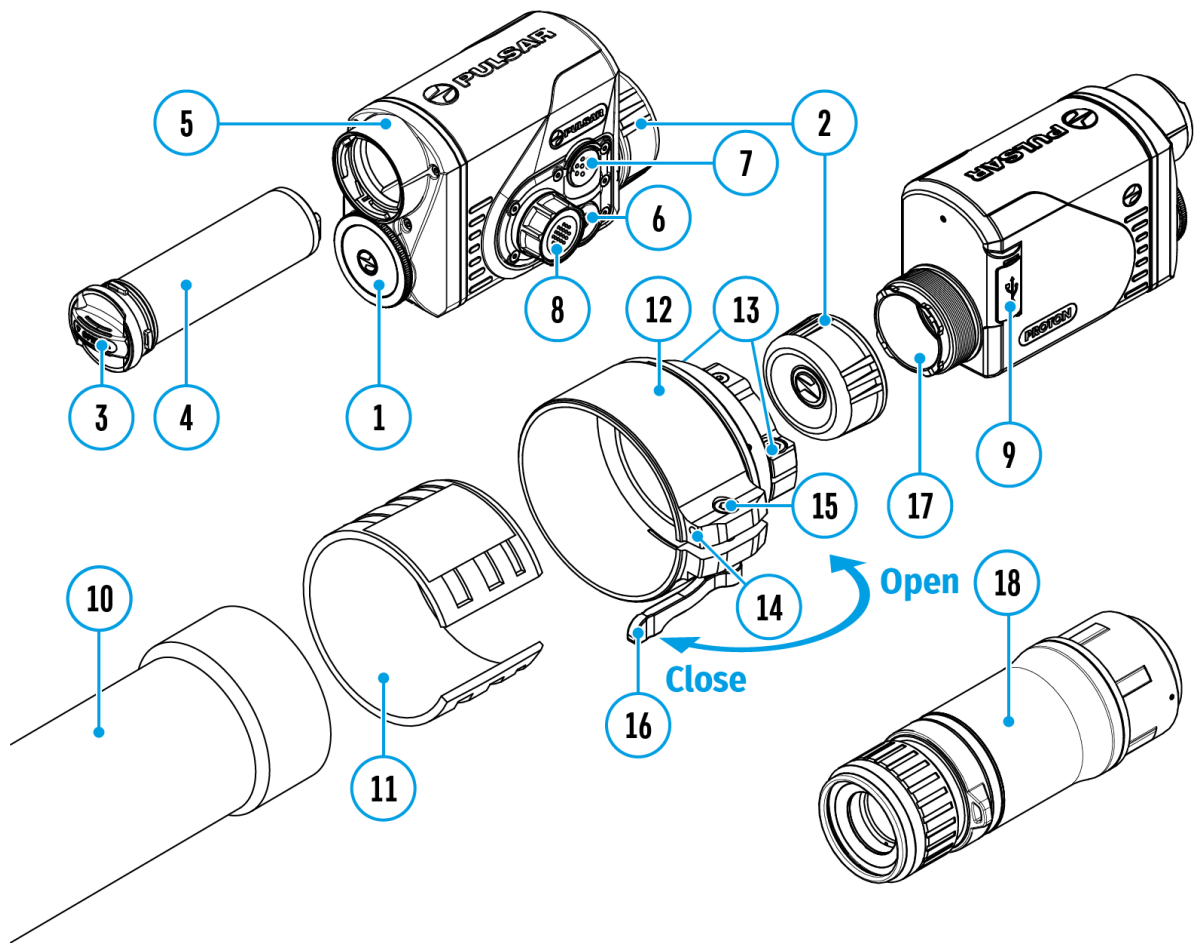

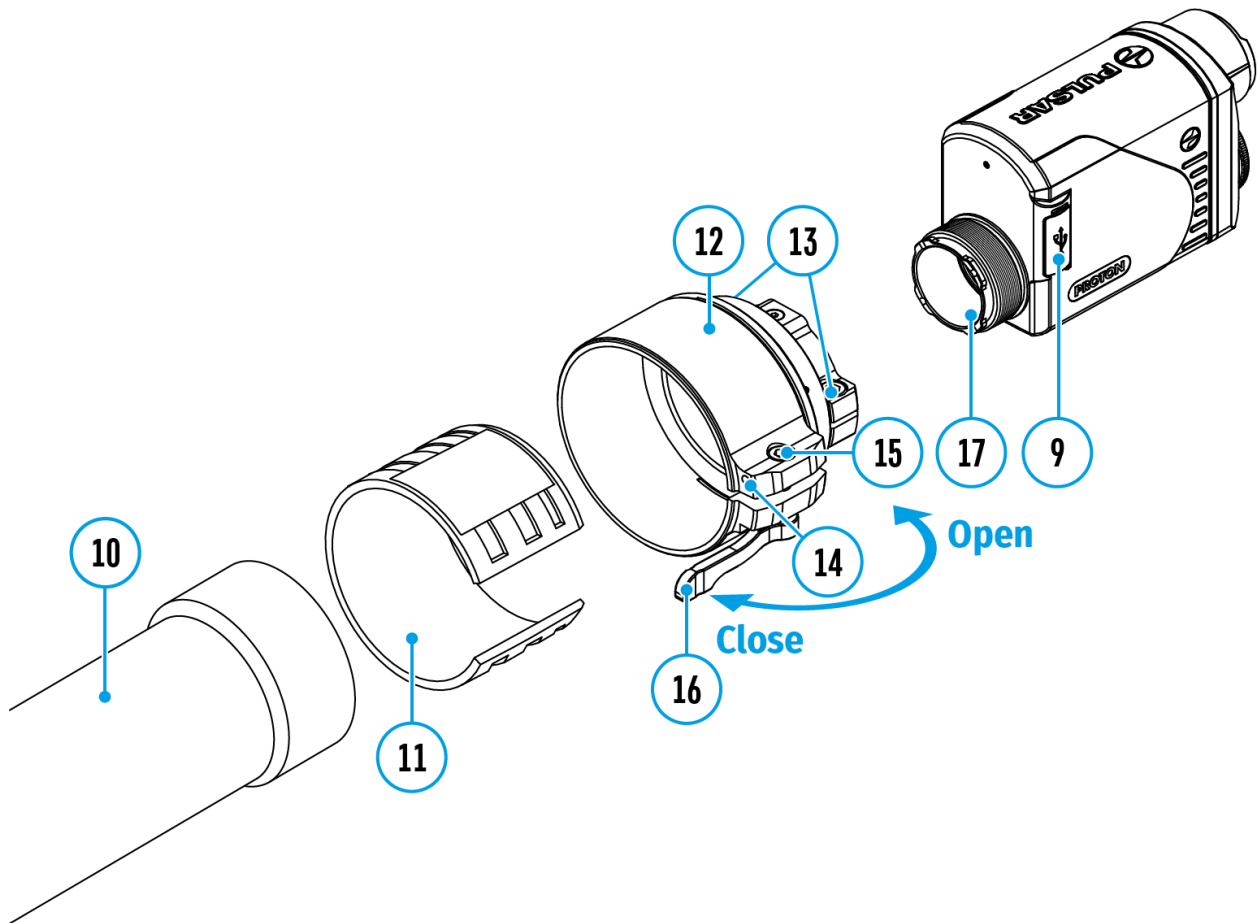

1. Remove the eyepiece cover **(2)**.

2. Select the Ring Adapter **(12)** (sold separately) with the insert **(11)** of the desired diameter depending on the outer diameter of the lens of your optical device **(10)** (see **Table**). The designation 42 mm / 50 mm / 56 mm in the name of the adapter means the lens diameter of the optical device.

3. Screw together the Ring Adapter **(12)** and the thermal imaging module along the threads of the mounting area **(17)** until it stops. Then untighten a little (no more than one turn) so that the lever **(16)** is on the right side (see Figure).

4. Evenly tighten the screws **(13)** until the ball joint grips in the Ring Adapter **(12)**.

5. Apply 2-3 strips of double-sided tape to the outer surface of the insert **(11)** of your choice.

6. Push the insert **(11)** of your choice into the Ring Adapter **(12)** until it stops.
7. Move the lever **(16)** to the OPEN position.
8. Before installing the Ring Adapter **(12)** onto the optical device, it is recommended to decrease the lens body of the optical device**(10)**.
9. Mount the Ring Adapter **(12)** with the insert **(11)** onto the lens of the daylight optical device **(10)** as far as it will go.
10. If the Ring Adaptor **(12)** with the insert **(11)** selected according to the table cannot be mounted onto the lens **(10)**, follow the steps below:
 - Loosen the locking screw **(14)** with a 2mm Allen key.
 - Untighten the screw **(15)** with a hex wrench (S = 4mm) until the Ring Adaptor with the insert can be mounted onto the lens **(10)**.
11. Move the lever **(16)** from its initial OPEN position to the CLOSE position.
12. Loosen the locking screw **(14)** with a 2mm Allen key, if it hasn't been done before.
13. Tighten the screw **(15)** using a 4mm Allen key. The clamping force should be 1.5-2 Nm (use a torque screwdriver) to ensure the lever is correctly tightened**(16)**, while the Ring Adapter with the thermal imaging module should not move relative to the body of the optical device **(10)**. If necessary, tighten or loosen the screw**(15)** to operate the lever **(16)** in the best way possible.
14. Tighten the locking screw **(14)** as far as it will go.
15. Turn on the thermal imaging module by briefly pressing the **ON/OFF(6)** button.
17. Turn on the device and align the image center on the **Proton XQ30** display with the image center of the daylight optical device by carefully tilting the thermal imaging module.
18. Align the top and bottom display boundaries of the **Proton XQ30** parallel to the horizontal line of the daylight optical device's reticle. Having reached the best possible position of the thermal imaging module, tighten

the two screws **(13)** until stop. The clamping force should be 6.5-7.5 N·m (use a torque screwdriver to check).

Selection table for optical device inserts

Ring Adapter model	The internal diameter of the insert needs to match the outer diameter of the objective lens housing of the daylight optical device it is being installed on.	
	Insert internal diameter, mm	Suitable for lens housing of daylight optical devices with an outer diameter of, mm
PSP Ring Adapter 42 mm	45.5	45.5
	46	46
	46.5	46.5
	47	46.7-47.6
	48	47.7- 48.6
	49	48.7-49.6
	50	49.7-50.6
PSP Ring Adapter 50 mm	51.6	51.6
	53.4	53.4
	55	54.7-55.6
	56	55.7-56.6
	57	56.7-57.6
	58	57.7-58.6
	59	58.7-59.6

PSP Ring Adapter 56 mm	60	59.7-60.6
	61	60.7-61.6
	62	61.7-62.6
	63	62.7-63.6
	64	63.7-64.6
	65	64.7-65.6

Installing Pulsar 5x30 B Monocular on to the Proton XQ

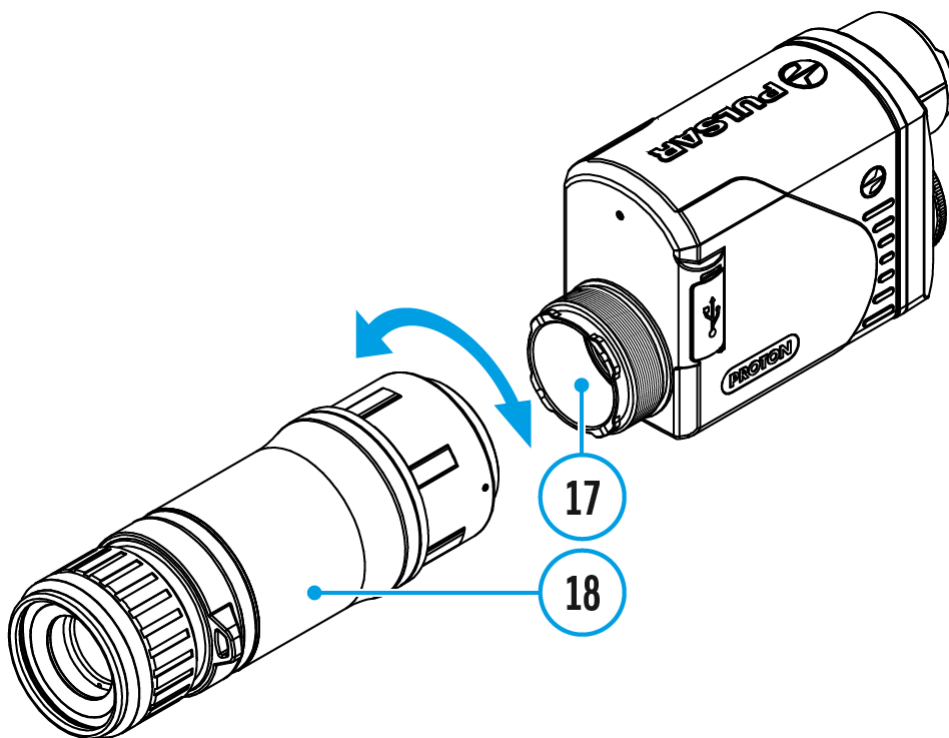

The **Pulsar 5x30 B monocular (18)** allows you to transform the **Proton XQ30** into a hand-held thermal imager with 5x magnification.

1. Align the tabs on the monocular with the slots of the mount **(17)**.
2. Turn the monocular clockwise to secure it on the thermal imaging module.
3. To remove the monocular, turn it counterclockwise and disconnect from the thermal imaging module.

Notes:

- The monocular can be installed on a thermal imaging module with an adapter already installed. The Ring Adaptor must be mounted onto the

mounting area of the thermal imaging module until it stops.

- The monocular can be installed on the device with an adapter installed only if the original PSP adapter is installed. This may not be possible when using an adapter from other manufacturers.
- The single-point neck strap (included in the delivery package) can be used with the monocular.

Powering on and Image Setting

Show device diagram

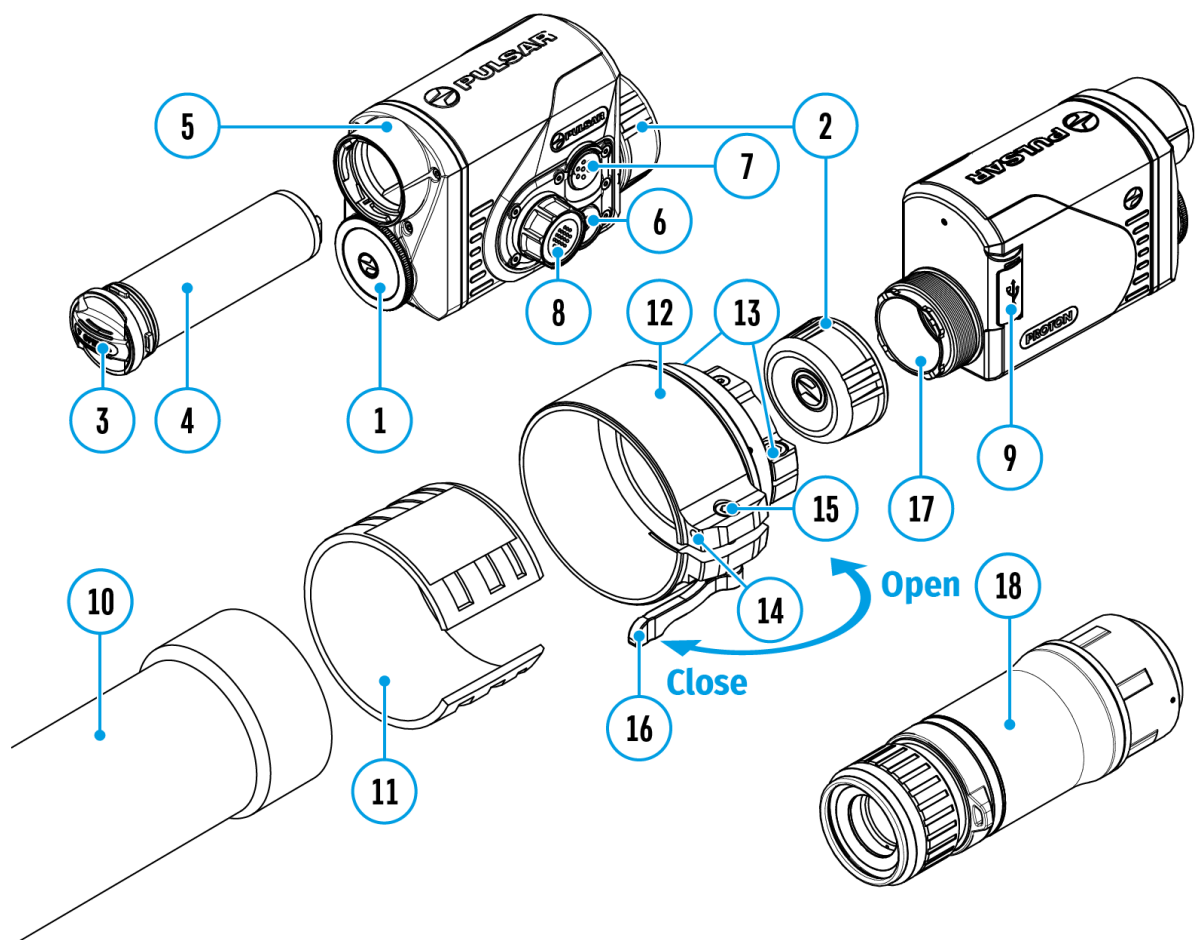

1. Remove the lens cover **(1)**.
2. Press the **ON/OFF(6)** button to turn on the thermal imager.
3. Adjust the eyepiece diopter ring of your daylight optical device until the symbols in the display are sharp. In future, it will not be necessary to adjust the eyepiece diopter, regardless of the distance and other conditions.
4. Enter the main menu with a long press of the controller button **(8)** and select the desired calibration mode: **manual (M)**, **semi-automatic (SA)**

or **automatic (A)**.

5. Calibrate the image by briefly pressing the **ON/OFF (6)** button. Close the lens cover before manual calibration.
6. Select the desired observation mode (**Forest, Rocks, Identification** or **User**) in the main menu. User mode allows you to configure and save custom brightness and contrast settings, as well as one of three modes as a base.
7. Enter the main menu with a long press of the controller button **(8)** and select the desired color palette (see the **Color Modes** section).
8. Activate the quick menu by briefly pressing the controller button **(8)** to adjust the brightness and contrast of the display (see the **Quick Menu Functions** section).
9. Upon completion of use turn the device off by a long press of the **ON/OFF(6)** button.

Warning! Never point the lens at intensive energy sources such as laser radiation emitting devices or the sun. It can damage electronic components in the device. The warranty does not cover damage arising from failure to comply with the operating rules.

Microbolometer Calibration

Show device diagram

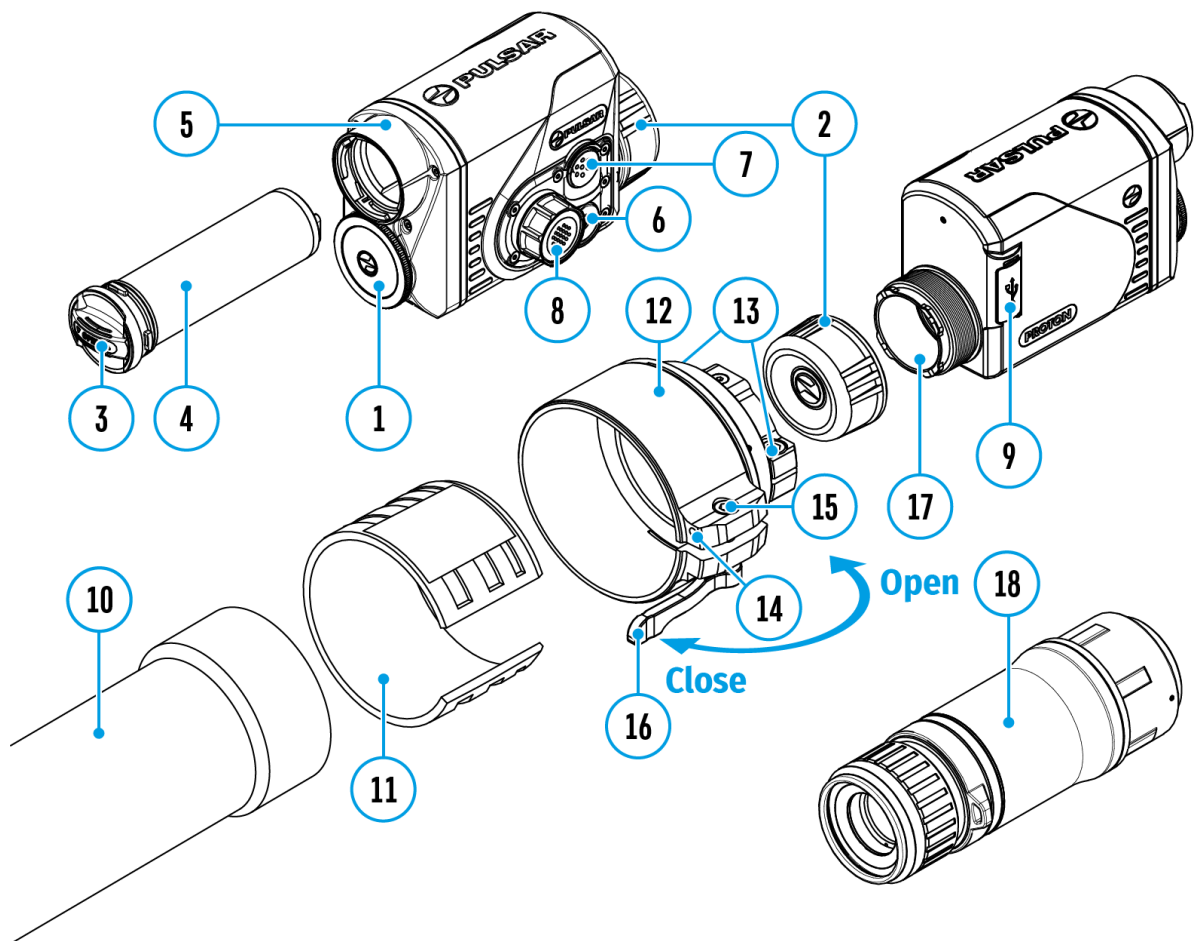

Calibration enables the microbolometer temperature background to be equalized and defects in the image (such as vertical lines, phantom images etc.) to be eliminated.

During calibration, the image on the display freezes briefly for up to 1 second.

There are three calibration modes: **manual (M)**, **semi-automatic (SA)** and **automatic (A)**.

Select the required mode in the **Calibration Mode**  section of the menu.

M mode (manual)

- Secure the lens cover **(1)** and briefly press the **ON/OFF (6)** button.
- After completing the calibration process, remove the lens cap.

SA mode (semi-automatic)

- Calibration is engaged by a brief press of the **ON/OFF(6)** button.
- The lens cap does not need to be secured (the microbolometer is closed by an internal shutter).

A mode (automatic)

- The device is calibrated autonomously, in accordance with the firmware algorithm.
- The lens cap does not need to be secured (the microbolometer is closed by an internal shutter).
- In this mode, the device may be calibrated by the user using the **ON/OFF(6)** button.

Status Bar

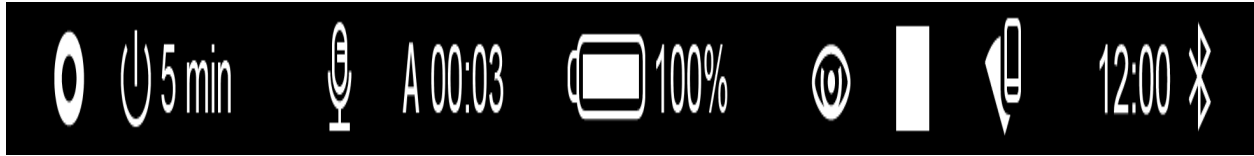

The status bar is at the bottom of the display and displays information on the actual operating status of the device, including:

- Color Mode (shown only when the Black Hot color mode is selected)
- Auto shutdown function (for example, 1 min)
- Microphone
- Calibration Mode (in Automatic calibration mode a countdown timer will appear instead of the calibration mode icon 3 seconds before automatic calibration begins).
- Power Indication:

 - charge level if the device is powered by a battery

 - charge level if the device is charging and powered by a battery

 - no battery, the device is connected to an external power supply

- Observation Mode
- Video recording status:

 - video recording is on

 - pause

 - video recording is off

- Wi-Fi Connection
- Time
- Bluetooth

Quick Menu Functions

Show device diagram

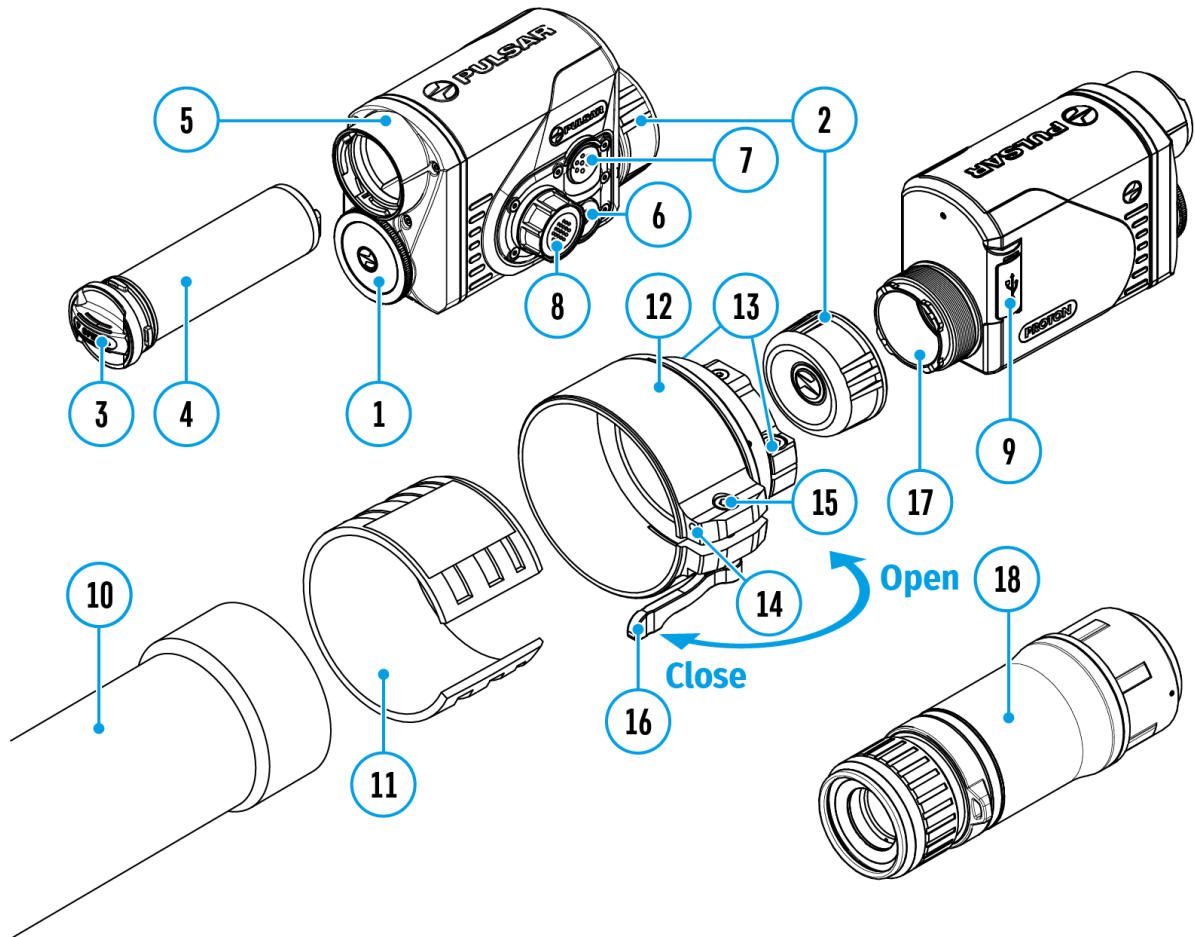

-
- Enter the menu with a short press of the controller button **(8)**.
 - To select the functions below, press successively the controller button **(8)**.

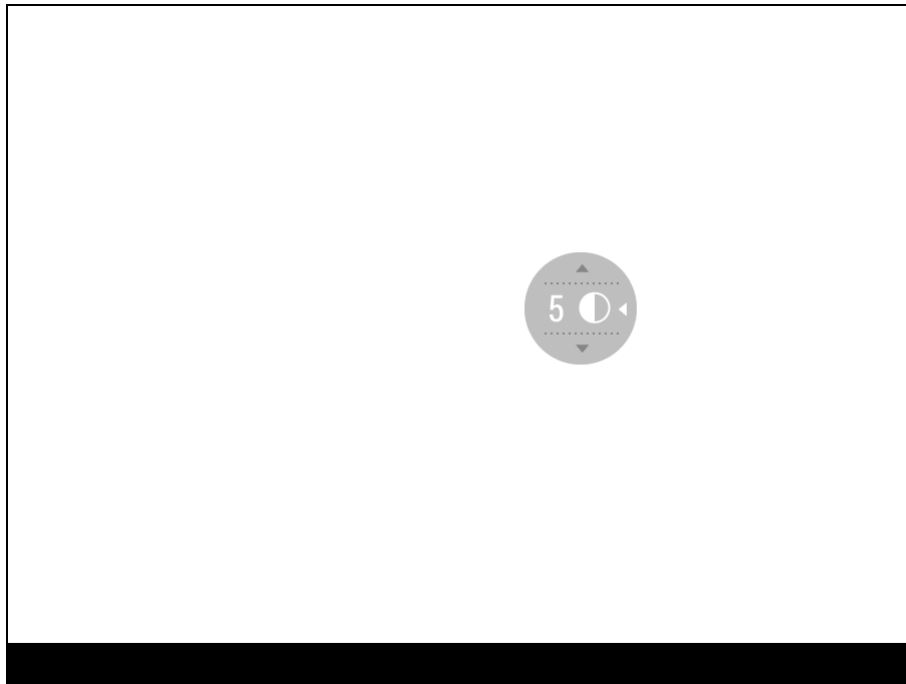

Contrast  - rotate the controller ring **(8)** to change the display contrast value from 0 to 20.

Brightness  - rotate the controller ring **(8)** to change the display brightness value from 0 to 20.

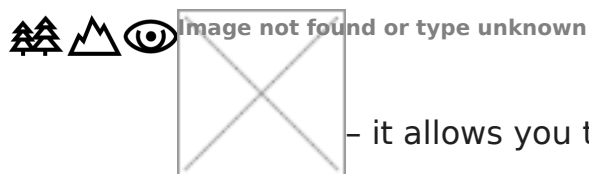

Basic mode - it allows you to select one of the three observation modes (Forest, Rocks, Identification) as the basic one for the user mode.

- To exit the menu, press and hold down the controller button **(8)**, or wait 10 seconds for automatic exit.

Enter the Main Menu

Show device diagram

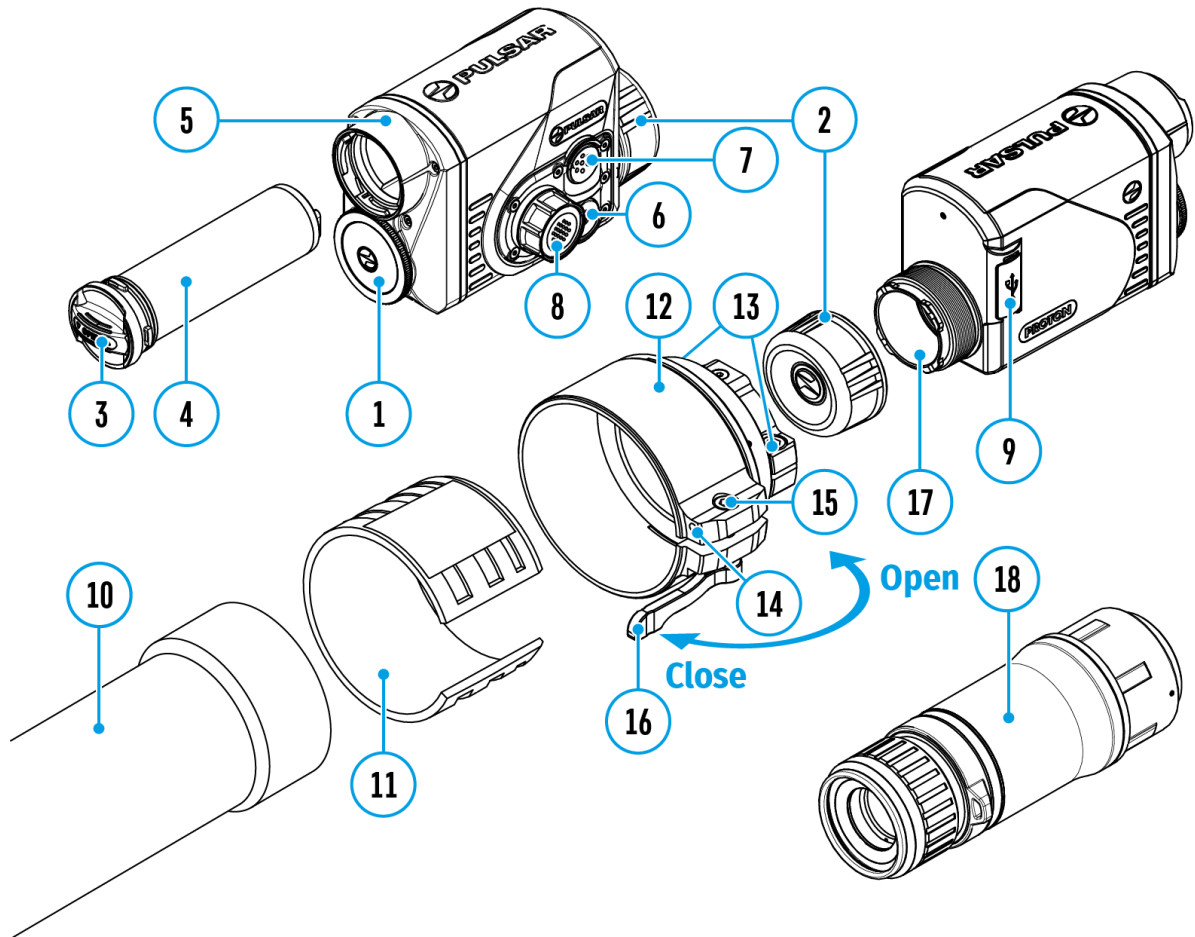

1. Enter the menu with a long press of the controller button **(8)**.
2. Rotate the controller ring **(8)** to move through the menu functions.
3. One short press of the controller button **(8)** opens a menu item.
4. To exit the menu, press and hold down the controller button **(8)**.

Automatic exit from the menu occurs after 10 seconds of inactivity.

Note: When entering the main menu, the background image darkens to enhance the menu visibility. This is normal and not a defect.

General view of the menu:

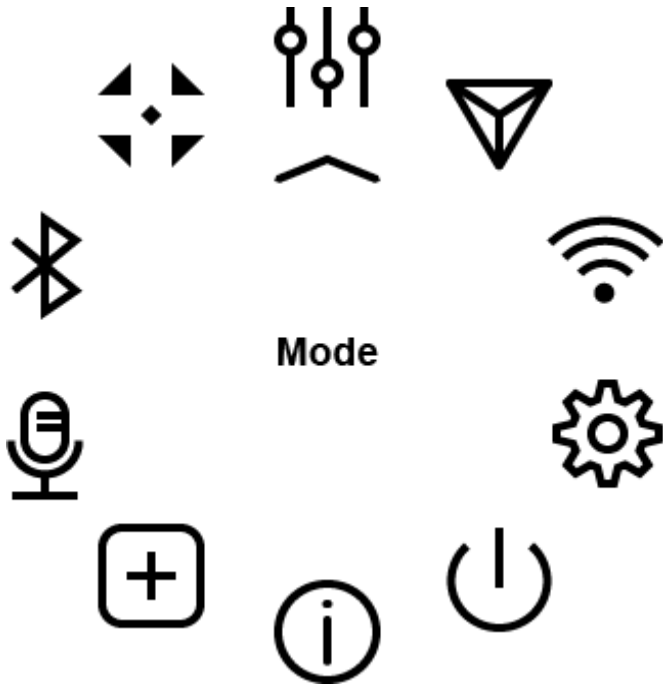

Mode

Show device diagram

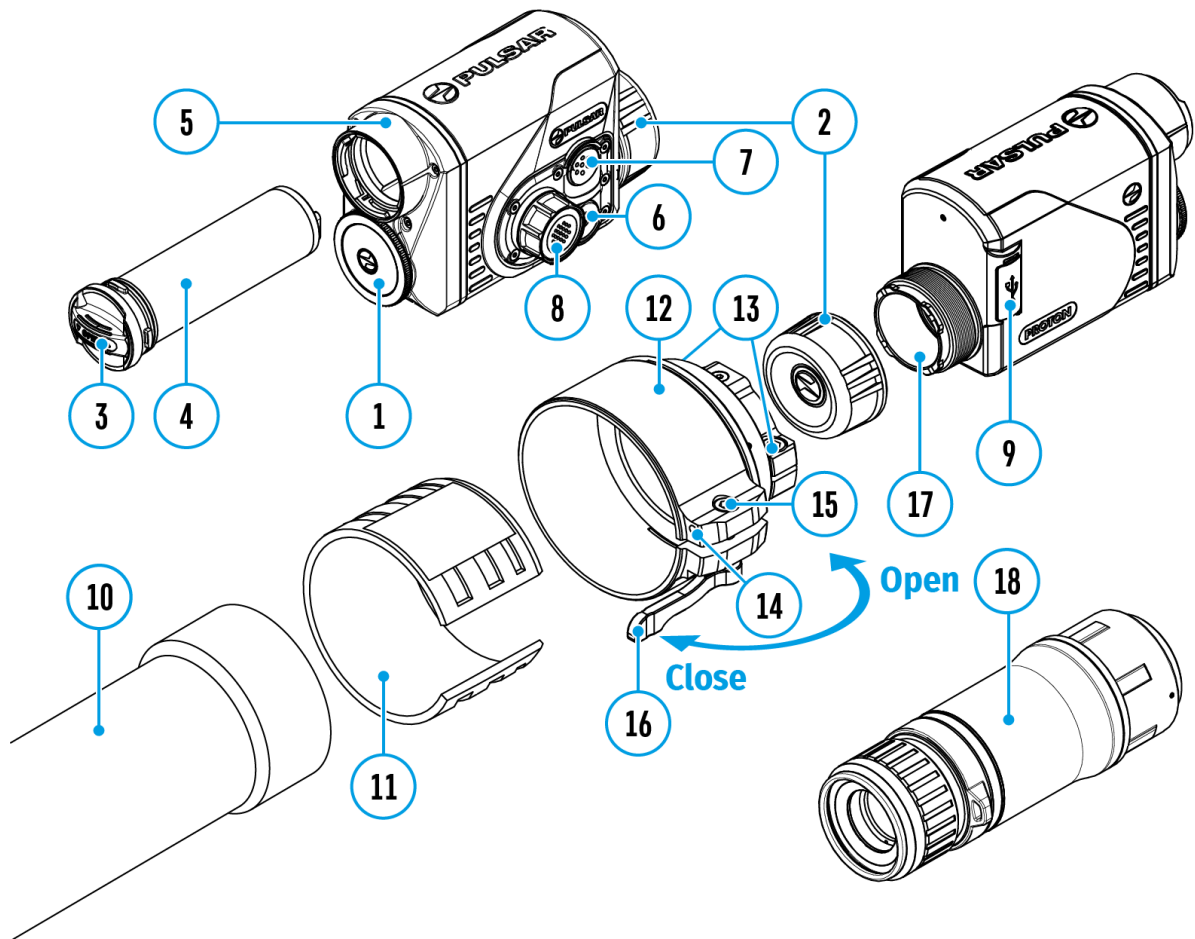



Observation mode selection

The device has four observation modes of the thermal imager: Forest (observation mode of objects within low thermal contrast conditions), Rocks (observation mode of objects within high thermal contrast conditions), Identification (high detailization mode), and User (individual brightness and contrast settings).

1. Press and hold the controller button **(8)** to enter the menu.
2. Rotate the controller ring **(8)** to select the **Mode**  menu item.
3. A short press of the controller button **(8)** opens the menu.

4. Rotate the controller ring **(8)** to select one of the modes: Forest, Rocks, Identification, and User.
5. A short press of the controller button **(8)** confirms the selection.

 **Rocks.** This is the best mode when observing objects after a sunny day or within urban conditions.

 **Forest.** This is the best mode when searching and observing within field conditions, against the background of leaves, bushes and grass. The mode is highly informative about an object being observed as well as landscape details.

 **Identification.** This is the best mode when observing objects within adverse weather conditions (fog, mist, rain and snow). It allows you to recognize the characteristics of an object being observed more clearly. Increased detail may be accompanied by insignificant image graininess.



 **User.** It allows you to configure and save custom brightness and contrast settings, as well as one of the three modes (Forest, Rocks, Identification) as a base.

Image Detail Boost

<https://www.youtube.com/embed/GNezJKveMRc>

Show device diagram

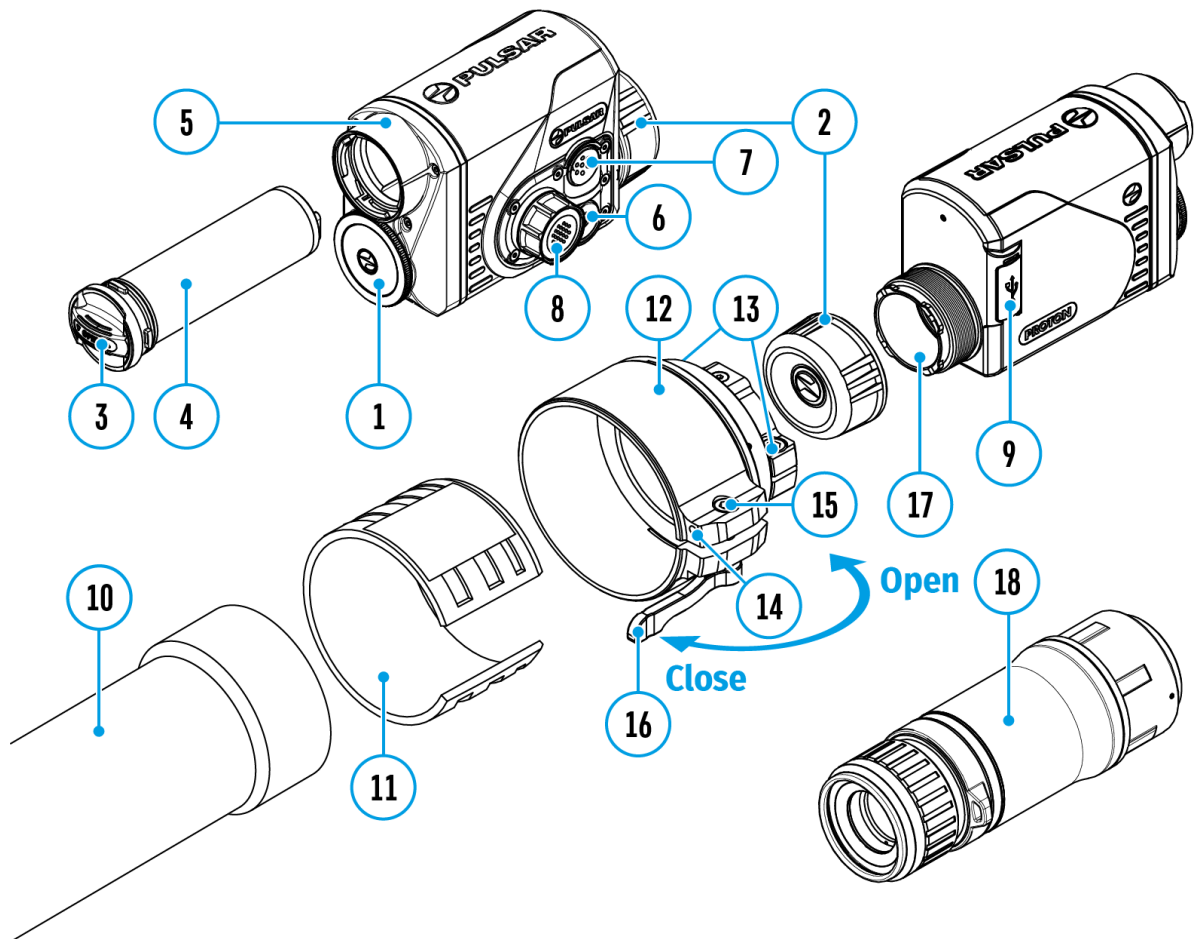

The **Image Detail boost**  function increases the sharpness of the contours of heated objects, which increases their detail. The result of the function depends on the selected mode and observation conditions: the higher the contrast of objects, the more noticeable the effect. This option is enabled by default, but can be disabled in the main menu.

Turn on/off Image Detail Boost

1. Press and hold the controller button **(8)** to enter the menu.
2. Rotate the controller ring **(8)** to select the **Image Detail Boost** .

menu item.

3. A short press of the controller button **(8)** opens the submenu.
4. To turn Image Detail Boost on or off press the controller button **(8)**.

Wi-Fi Settings

Show device diagram

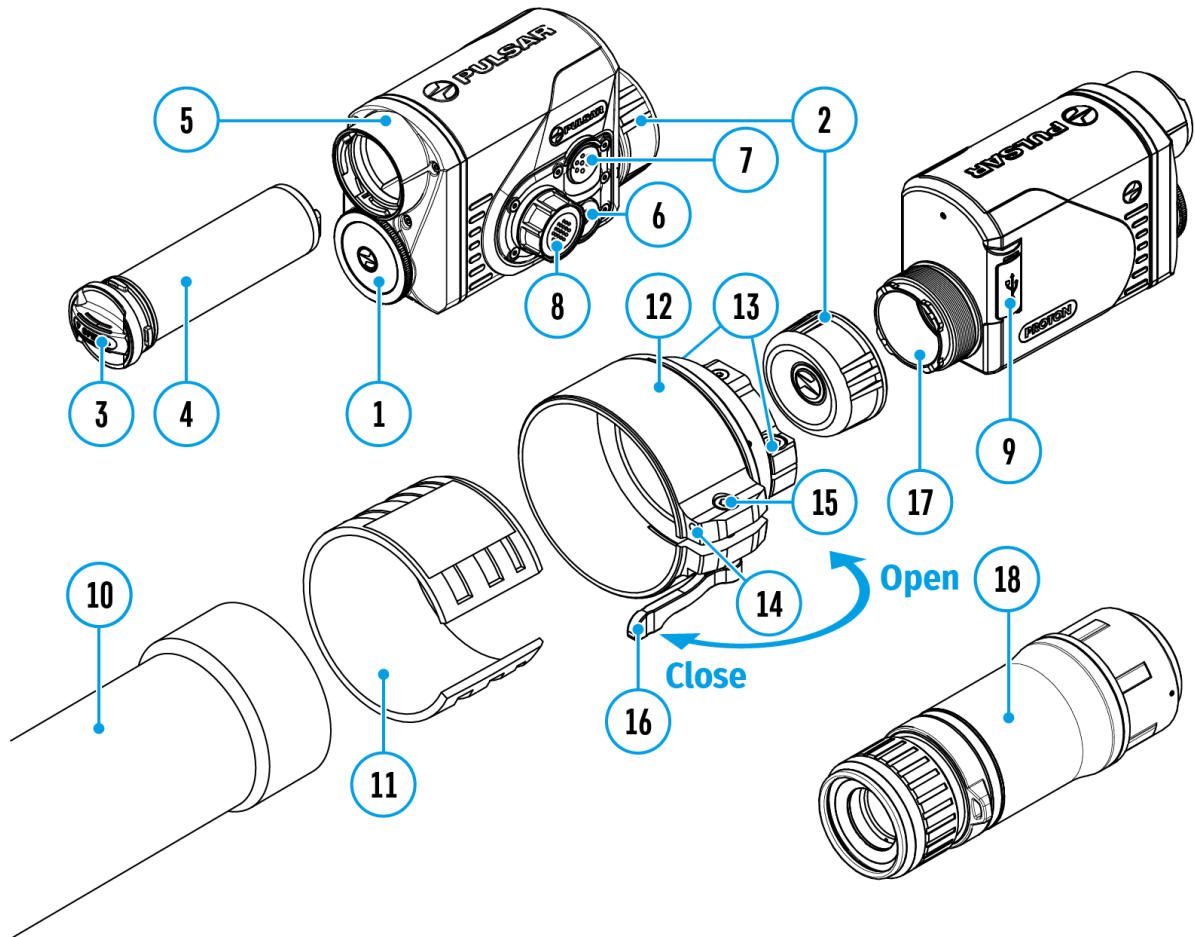

This menu option allows you to set up your device for operation in a Wi-Fi network.

1. Press and hold the controller button **(8)** to enter the menu.
2. Rotate the controller ring **(8)** to select the **Wi-Fi Settings**  menu item.
3. A short press of the controller button **(8)** opens the menu section.

Wi-Fi Activation

Turn Wi-Fi on/off

1. Rotate the controller ring **(8)** to select the **Wi-Fi Activation**  menu item
2. A short press of the controller button **(8)** opens the submenu.
3. To turn Wi-Fi on or off press the controller button **(8)**.

Password Setup

This submenu allows you to set a password to access your thermal rifle scope from a mobile device.

1. Rotate the controller ring **(8)** to select the **Password Setup**  menu item
2. A short press of the controller button **(8)** opens the submenu.
3. The default password **(12345678)** will appear on the screen.
4. Rotate the controller ring **(8)** to set your desired password. Press the controller button **(8)** to toggle the digits.
5. Press and hold down the controller button **(8)** to save the password and exit the submenu.

Access Level Setup

This submenu allows you to set access levels of Stream Vision application to your device.

- Access level **Owner**. Stream Vision user has complete access to all device's functions.
- Access level **Guest**. Stream Vision user has access only to real time video stream from the device.

1. Rotate the controller ring **(8)** to select the **Access Level Setup**  menu item.
2. A short press of the controller button **(8)** opens the submenu.
3. Rotate the controller ring **(8)** to select **Owner** or **Guest**.
4. Confirm your selection with a short press of the controller button **(8)**.

General Settings

Show device diagram

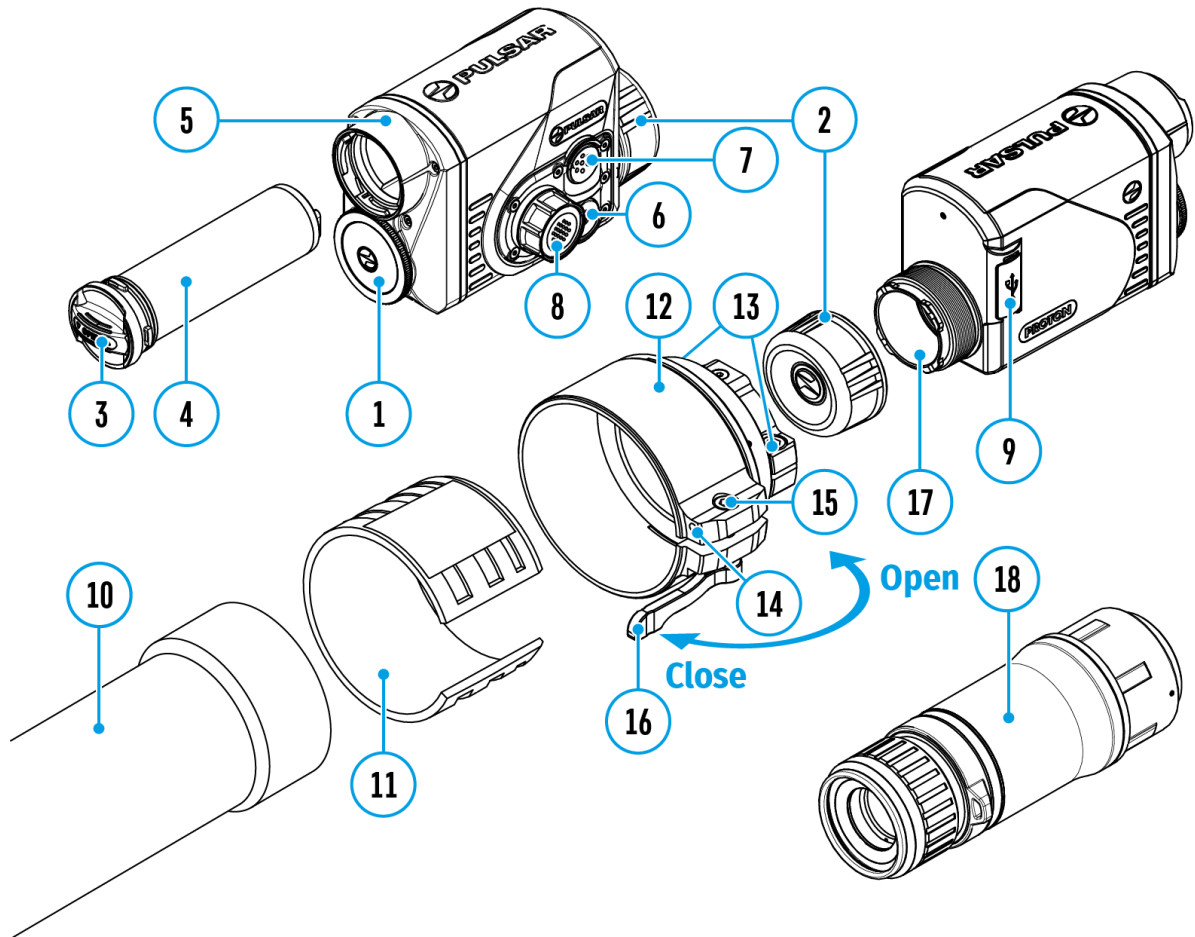

This menu section allows you to change the interface language, set the date, time, units of measure, return the device to factory default settings and perform memory card formatting.

1. Press and hold the controller button **(8)** to enter the menu.
2. Rotate the controller ring **(8)** to select the **General Settings**  menu item.
3. A short press of the controller button **(8)** opens the submenu.

Icon Brightness

Adjust brightness level of the icons and screensavers (Pulsar, Display off) on the display.

1. Rotate the controller ring **(8)** to select the **Icon Brightness**  icon.
2. Press the controller button **(8)** briefly to enter the submenu.
3. Rotate the controller ring **(8)** to select the desired brightness level from 0 to 10.
4. Press the controller button **(8)** briefly to confirm the selection.

Language

Language selection

1. Rotate the controller ring **(8)** to choose **Language**  menu item.
2. Press the controller button **(8)** briefly to confirm the selection.
3. Rotate the controller ring **(8)** to select one of the available interface languages: English, German, Spanish, French, and Russian.
4. Press the controller button **(8)** briefly to confirm the selection.

Auto Shutdown

This item allows you to activate the auto shutdown function for when the device is in a non-operating position (tilted up or down at an angle of more than 70°, right or left at an angle of more than 30°).

1. Rotate the controller ring **(8)** to choose **Auto Shutdown**  menu item.
2. Press the controller button **(8)** briefly to confirm the selection.
3. Rotate the controller ring **(8)** to select the time period (1 min, 3 min, 5 min) upon expiry of which the device will automatically shut down, or select Off if you wish to deactivate Auto Shutdown.
4. Press the controller button **(8)** briefly to confirm the selection.

Note: If the Auto Shutdown function is activated, the status bar shows an icon and shutdown time period as  1 min.

Date

Date setup

1. Rotate the controller ring **(8)** to choose **Date**  menu item.
2. Press the controller button **(8)** briefly to confirm the selection. The date appears in dd/mm/yyyy format (01/01/2021).
3. Rotate the controller ring **(8)** to set the required year, month and day. Press the controller button **(8)** to toggle the digits.
4. To save your chosen date and exit the submenu, press and hold the controller button **(8)**.

Time

Time setup

1. Rotate the controller ring **(8)** to choose **Time**  menu item.
2. Press the controller button **(8)** briefly to confirm the selection.
3. Rotate the controller ring **(8)** to select the time format (24-hour clock or AM/PM).
4. Switch to hour setup with a short press of the controller button **(8)**.
5. Select hour value with a short press of the controller button **(8)**.
6. Switch to minute setup with a short press of the controller button **(8)**.
7. Select minute value with a short press of controller button **(8)**.
8. Save selected time value and exit the submenu with a long press of the controller button **(8)**.

Default Settings

Restore default settings

1. Rotate the controller ring **(8)** to choose **Default Settings**  menu item.
2. Press the controller button **(8)** briefly to confirm the selection.

3. Rotate the controller ring **(8)** to select **Yes** to restore default settings or **No** to cancel.
 4. Confirm your selection with a short press of the controller button **(8)**.
- If **Yes** is selected, display will show "**Do you want to restore default settings?**" and **Yes** and **No**. Select **Yes** to restore the default settings.
 - Selecting the **No** option will cancel the reset and exit the submenu.

The following settings will be returned to their defaults before being changed by the user:

- **Video Recorder Mode** - Video
- **Observation Mode** - Forest
- **Calibration Mode** - Automatic
- **Language** - English
- **Wi-Fi** - Off (default password)
- **Color Mode** - White Hot

Attention! When restoring the factory defaults the date, time and user pixel map are saved.

Format

This function enables you to format the Flash memory card. All files will be deleted.

Formatting should be carried out in case of a memory card error.

Before formatting, make sure you transfer all footage to other media.

1. Rotate the controller ring **(8)** to choose **Format**  menu item.
 2. Press the controller button **(8)** briefly to confirm the selection.
 3. Rotate the controller ring **(8)** to select Yes to format the memory card or No to return to the submenu.
 4. Press the controller button **(8)** briefly to confirm your selection.
- If Yes is selected, the message "**Do you want to format the memory card?**" appears on the display as well as **Yes** and **No**. Select **Yes** to format the memory card.
 - Selecting the **No** option will cancel the formatting and exit the submenu.

Color Modes

Show device diagram

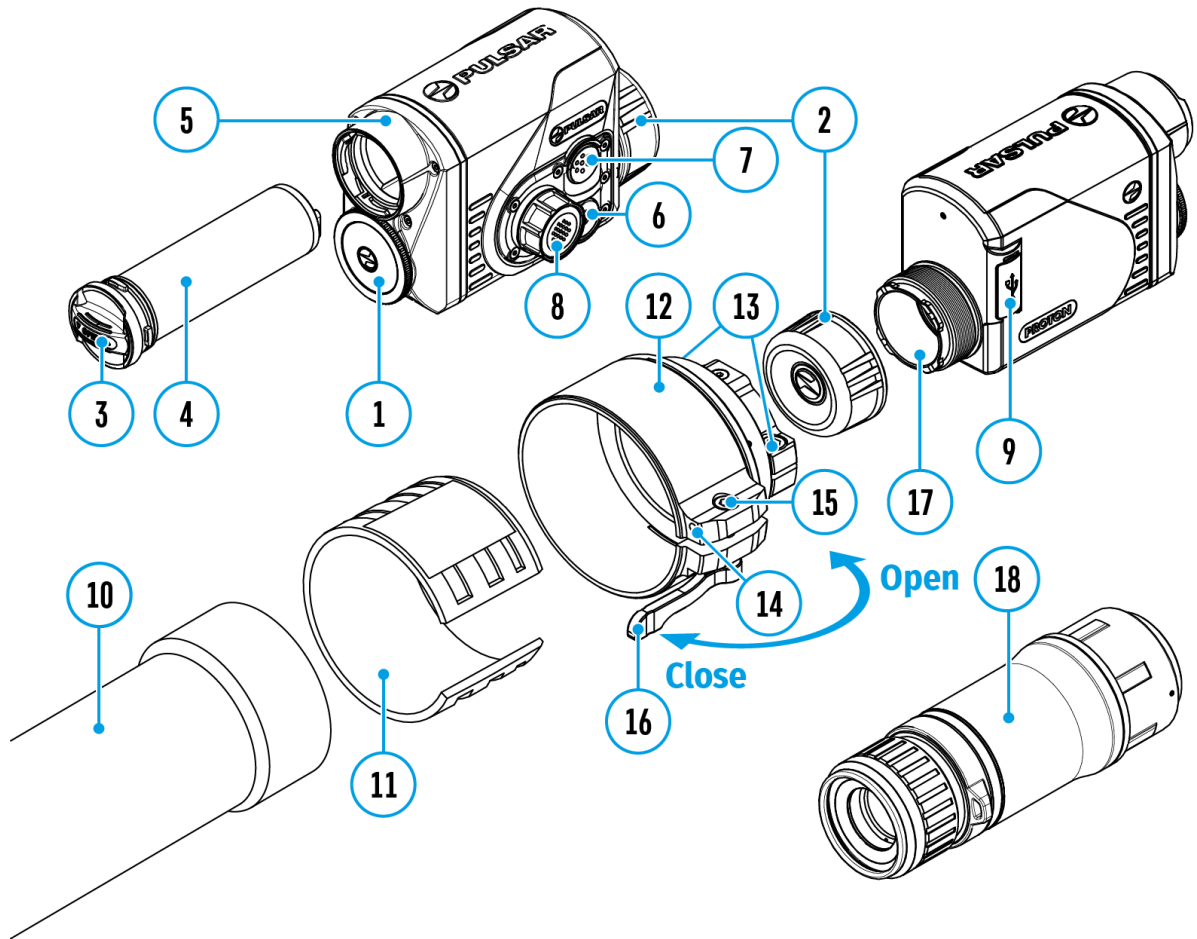



Color palette selection

White Hot is the default display mode. To select an alternative palette, do the following:

1. Press and hold the controller button **(8)** to enter the main menu.
2. Rotate the controller ring **(8)** to select **Color Modes**  icon .
3. Press the controller button **(8)** briefly to enter the submenu.
4. Rotate the controller ring **(8)** to select the desired palette.
5. Press the controller button **(8)** briefly to confirm the selection.

Black Hot- a black and white palette where white corresponds to cold temperatures and black to hot temperatures.

Red Hot

Red Monochrome

Rainbow

Ultramarine

Violet

Sepia

Device Information

Show device diagram

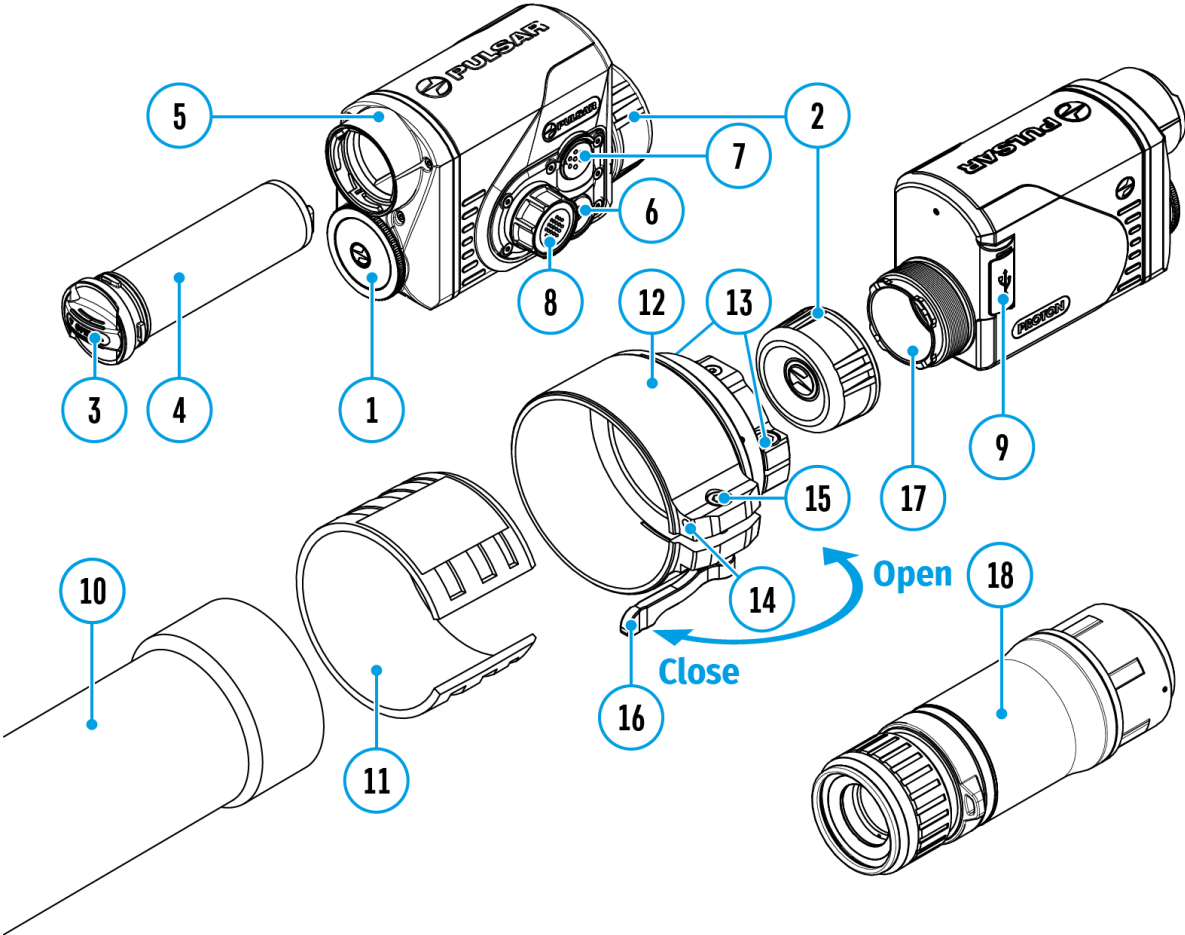

This menu item allows the user to view the following information about the device:

- SKU Number
- Firmware Version
- Device Name
- Hardware Version
- Device Serial Number
- Service Information

To display information, do the following:

1. Press and hold the controller button **(8)** to enter the main menu.
2. Rotate the controller ring **(8)** to select the **Device Information**  icon.
3. Press the controller button **(8)** briefly to view / exit the information.

Microphone

Show device diagram

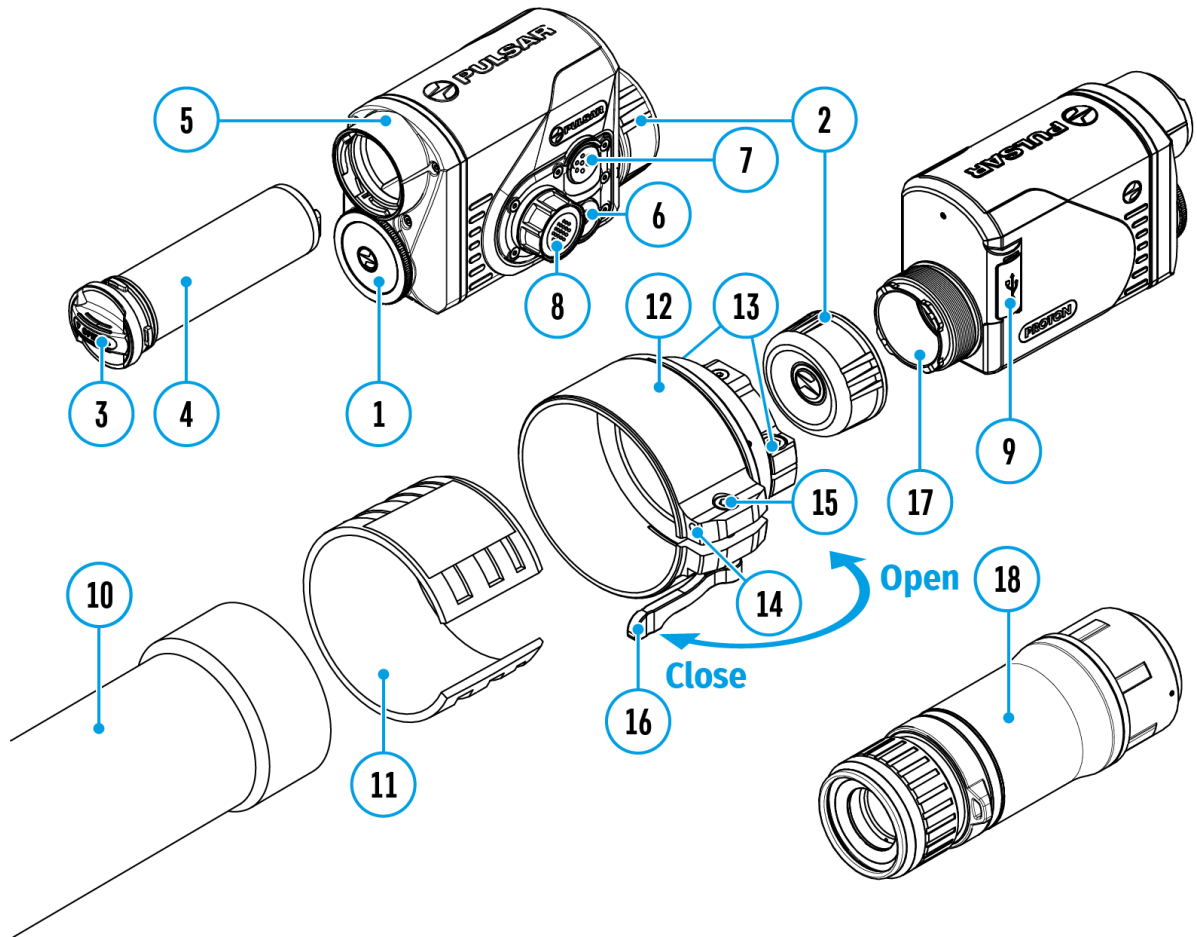

Turning microphone on / off.

This item allows you to enable (or disable) the microphone for recording sound during video recording.

1. Press and hold the controller button **(8)** to enter the main menu.
2. Rotate the controller ring **(8)** to select **Microphone**  icon.
3. A short press of the controller button **(8)** opens the submenu.
4. To turn the microphone on or off press controller button **(8)**.

Bluetooth

Show device diagram

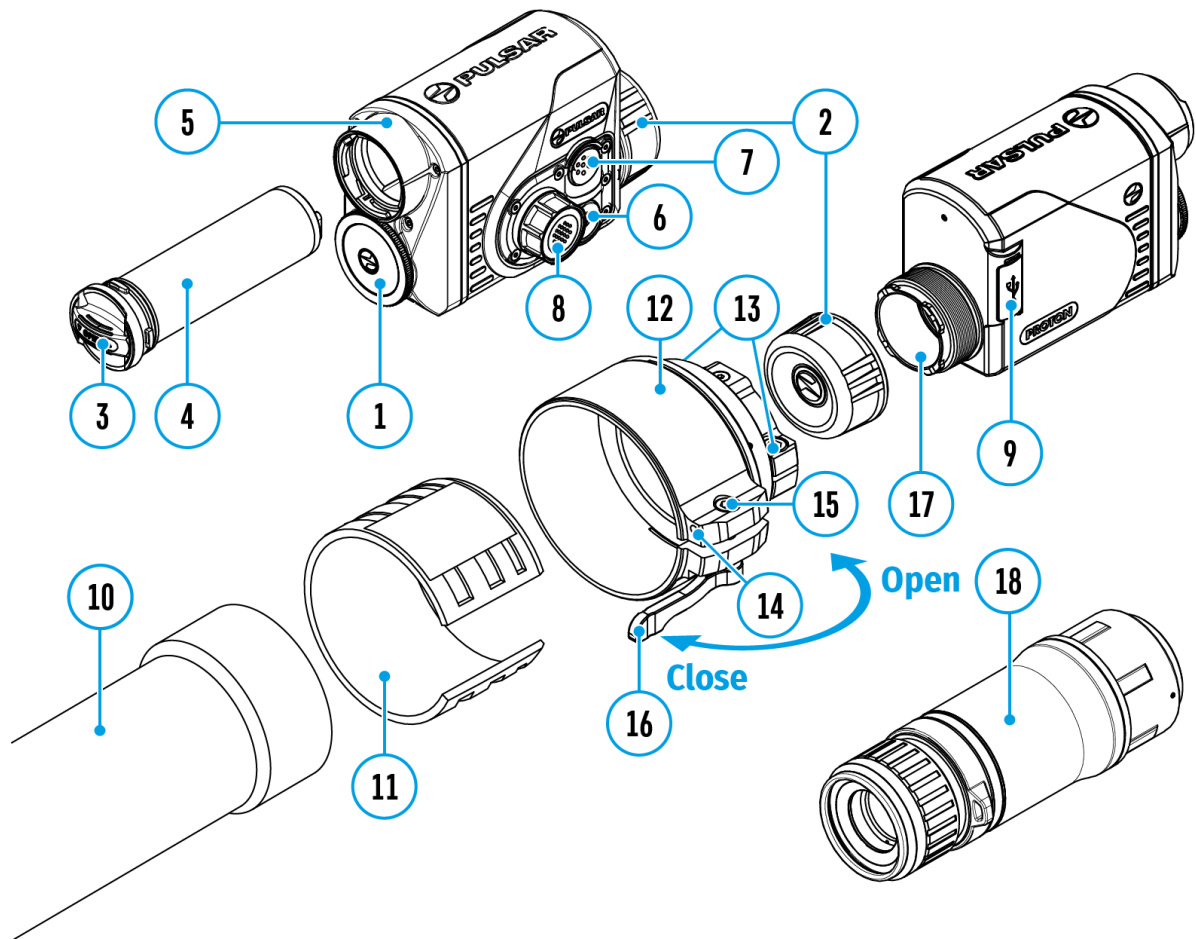

Turn on/off Bluetooth

1. Press and hold the controller button **(8)** to enter the main menu.
2. Rotate the controller ring **(8)** to select the **Bluetooth**  menu item.
3. A short press of the controller button **(8)** opens the submenu.
4. Turn Bluetooth on/off with a short press of the controller button **(8)**.
5. Press and hold down the controller button **(8)** to exit the submenu.

The process of connecting the wireless remote control is described in the [Remote Control Activation](#) section.

Calibration Mode

Show device diagram

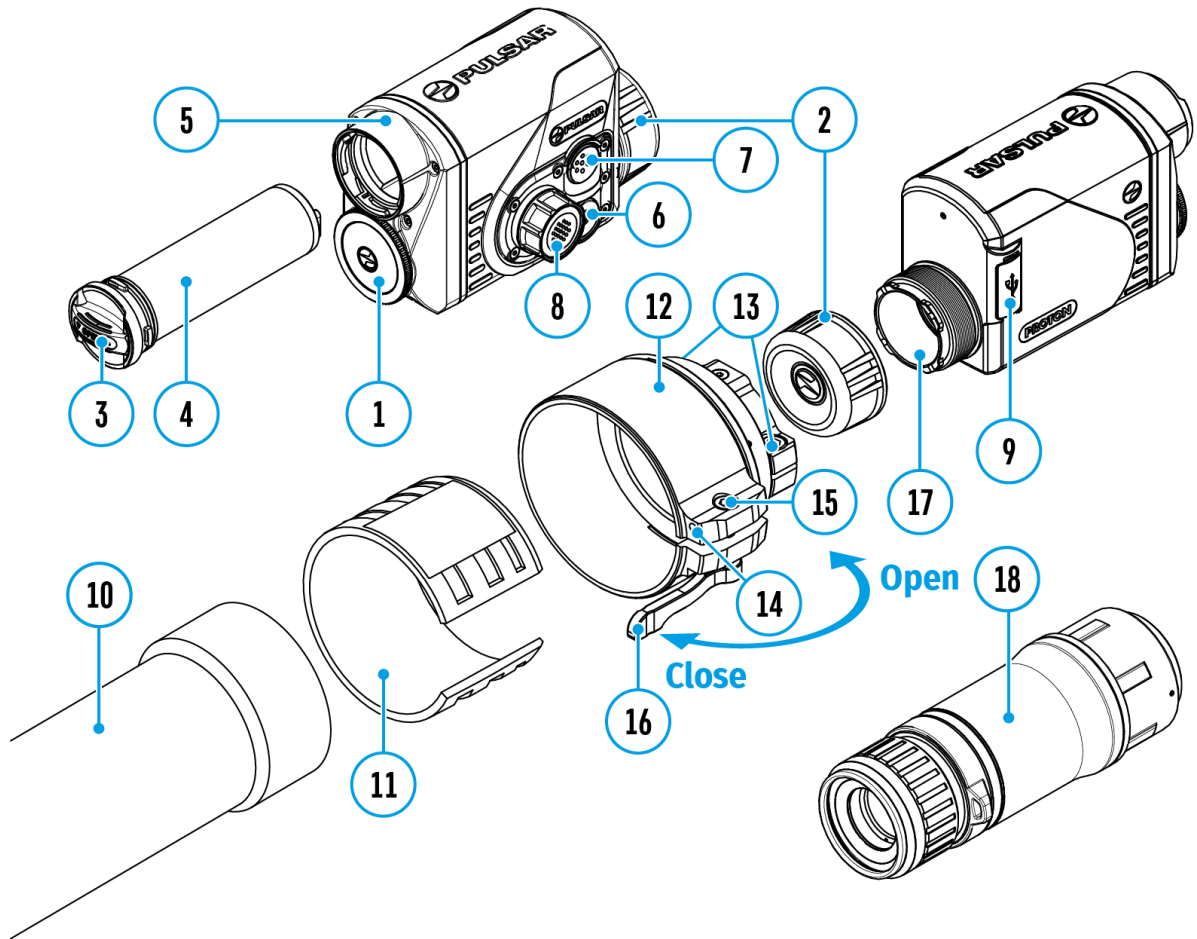

Calibration mode selection

There are three calibration modes: **Manual**, **Semi-Automatic** and **Automatic**.

1. Press and hold the controller button **(8)** to enter the main menu.
2. Rotate the controller ring **(8)** to select the **Calibration Mode**  icon.
3. Press the controller button **(8)** briefly to enter the submenu.
4. Rotate the controller ring **(8)** to select one of the calibration modes described below.
5. Press the controller button **(8)** briefly to confirm the selection.

Automatic (A). In this mode the firmware determines the need for calibration. The calibration process starts automatically.

Semi-Automatic (SA). The user determines the need for calibration based on the image quality and can action at a convenient time depending on the object being observed.

Manual (M). In the Manual (silent) calibration mode the user determines the need for calibration (as in **SA** mode) but the lens cover must be closed during calibration.

Video Recording and Photography

Show device diagram

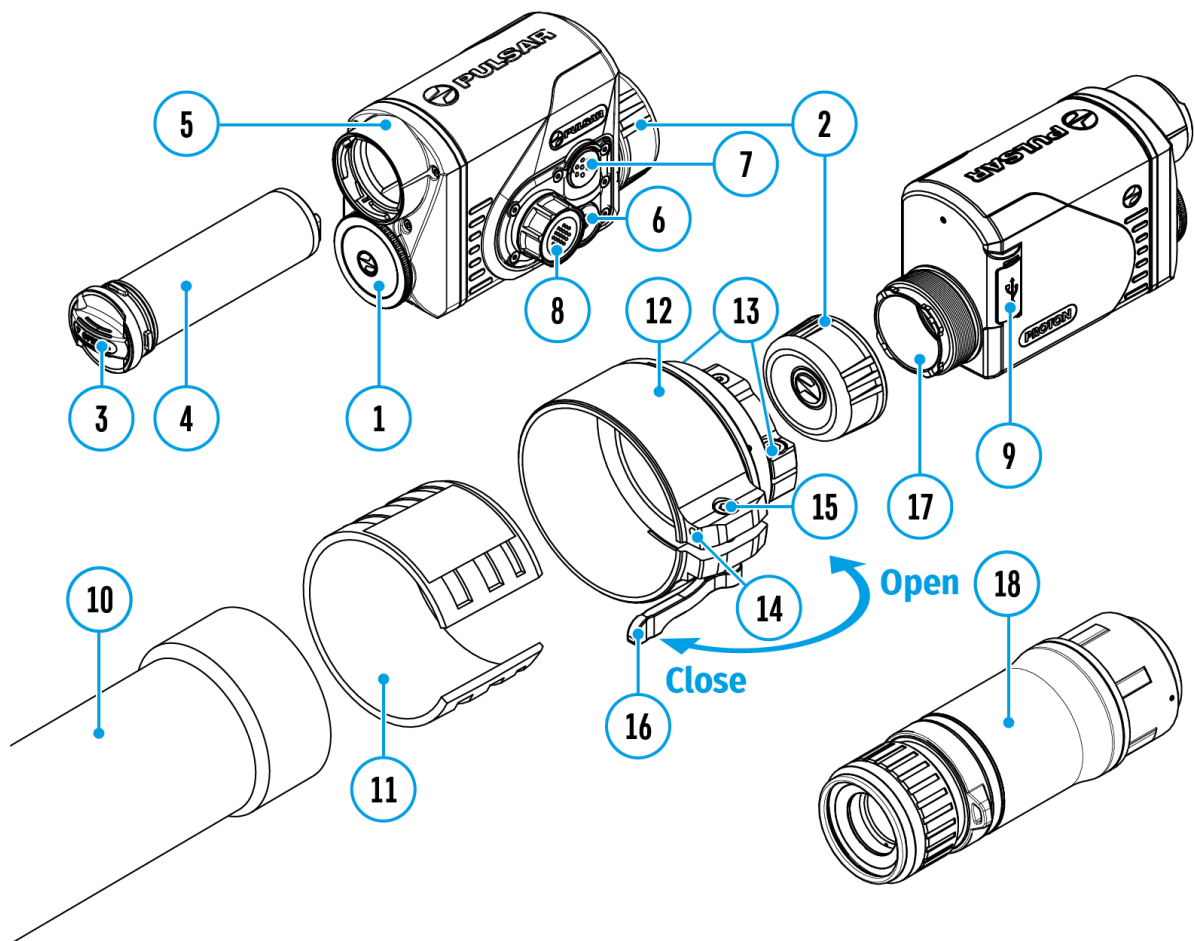

The **Proton XQ30** thermal imagers are equipped with the option to record video and still images (photography) of the observed image by saving them on the built-in memory card.

It is recommended to set the **date** and **time** (see the [General Settings](#) section) before using the photo and video functions.

The built-in recorder operates in two modes:

Video mode. Video Recording

1. Switch to **Video** mode by pressing and holding the **REC (7)** button.
2. The icon  and the remaining recording time in HH:MM (Hours:Minutes) format are displayed in the upper left corner for a short time, for example, 5:12. In the status bar, the video recording status is displayed continuously.
3. Press the **REC (7)** button briefly to start video recording.
4. When the video recording starts, the icon will disappear and the REC icon and timer in MM:SS (Minutes:Seconds) format will appear.
5. Press the **REC (7)** button briefly to pause or resume video recording.
6. Press and hold the **REC (7)** button to stop video recording.
7. Video files are saved to the built-in memory card after the video recording has been stopped.
8. Switch between modes (**Video**-> **Photo**-> **Video**) with a long press of the **REC (7)** button.

Photo mode. Capturing a photo

1. Switch to **Photomode** by pressing and holding the **REC (7)** button.
2. Press the **REC (7)** button briefly to take a photo. The image freezes for 0.5 sec while the photo is saved to the internal memory.

Notes:

- You can enter and navigate the menu during video recording.
- The recorded videos and photos are saved to the built-in memory card of the device in the formats img_xxx.jpg (photos) and video_xxx. mp4 (video) where xxx is a 3 digit counter.
- The counter for multimedia files cannot be reset.

Attention!

- The maximum duration of a recorded video file is five minutes. After this time expires, the video is recorded to a new file.
- The number of recorded files is limited by the capacity of the internal memory of the device.
- Regularly check the free capacity of the internal memory and move recorded footage to other storage media to free up space on the internal memory card.
- In case of a memory card error, you can use the format function in the **General Settings**

section of the main menu.





- When the Display Off function is activated, video recording is paused.



Wi-Fi Function

The device has a function enabling wireless communication with external devices (smartphone or tablet) via Wi-Fi.

- Turn on the wireless module in the **WI-Fi Activation**  menu option (see [Wi-Fi Settings](#) section).

Wi-Fi is displayed in the status bar as follows:

Connection Status	Indication on the status bar
Wi-Fi is switched off	
Wi-Fi connection is in progress	
Wi-Fi is switched on, no connection with device	
Wi-Fi is switched on, device connected	

- The device is recognized by an external device as PROTON_XXXX where XXXX are the four last digits of the serial number.
- After entering the password on the external device (see **Password Setup** subsection of the [Wi-Fi Settings](#) section for more information on setting a password) and setting up a connection, the icon  in the status bar changes to .

Display-Off Function

Show device diagram

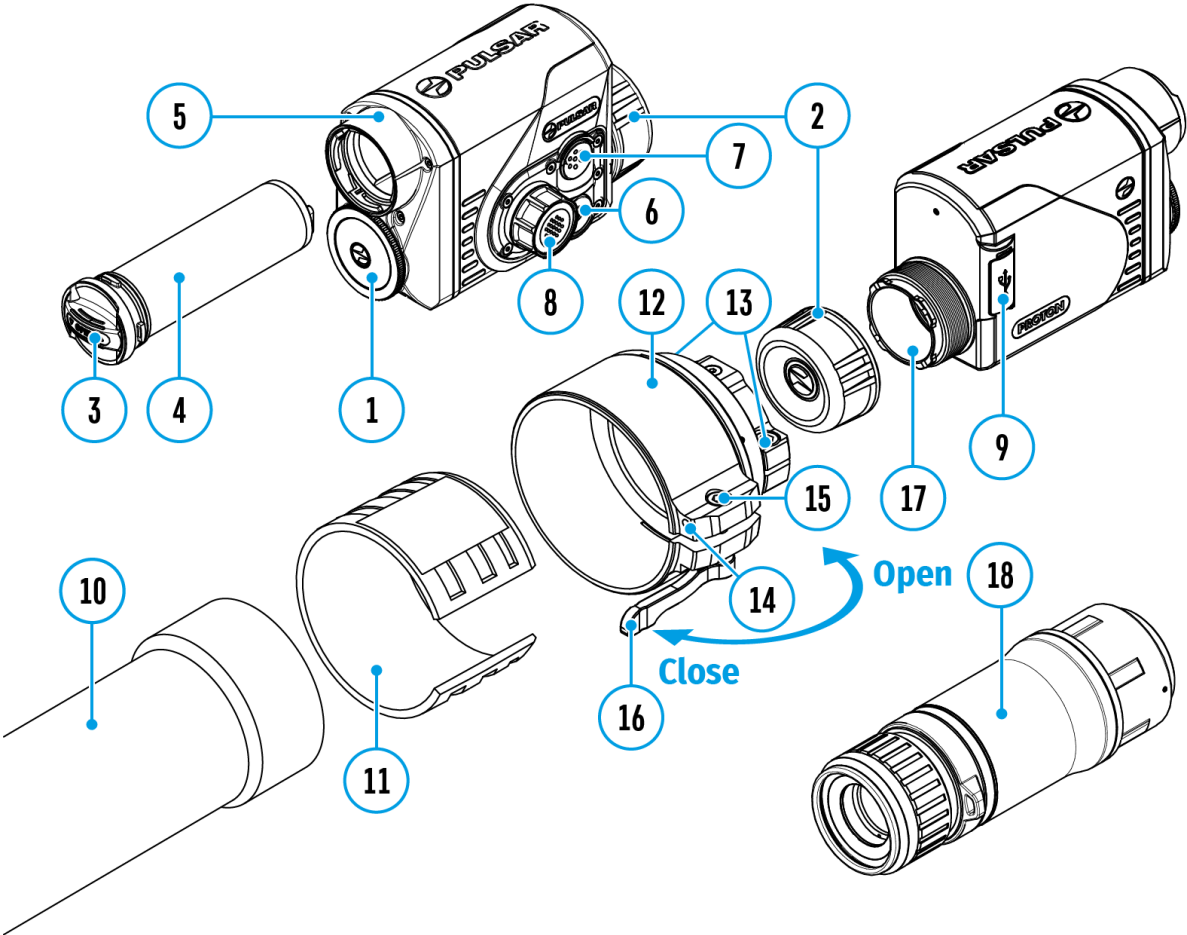

This function deactivates the image transmission to the display by minimizing its brightness. This helps prevent accidental disclosure. However, the device stays on.

When this function is in use, the device switches to the standby mode, which allows it to be switched on quickly if necessary.

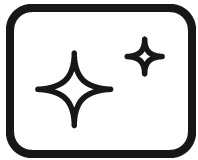

00:03

Display off

1. When the device is on, press and hold the **ON/OFF (6)** button for less than 3 seconds. The display goes blank and the message "**Display off**".
2. Press the **ON/OFF(6)** button briefly to turn on the display.
3. When you press and hold the **ON/OFF(6)** button, the display shows the message "**Display off**" with a countdown. Holding the button down for the duration of the countdown will power the device off completely.

Descriptions of Controls

The wireless remote control duplicates the functions of turning off the device, turning off the display, calibration, switching observation modes and palettes, video recording and photographing, and it allows navigation through the menu.

	Controller (25)	Button (26)	Button (27)	Button (28)
Short press	Enter the quick menu and submenus of the main menu / confirm the selection / Switch to the next item of the quick menu	Turn the display on / Calibrate the microbolometer	Switch observation modes	Start video recording / Capture a photo

Long press	Enter/exit the main menu / Exit the quick menu	Turn the display off / Turn the device off	Turn on/off the Black Hot palette	Switch to photo/video mode
-------------------	---	---	--	-------------------------------------



Clockwise rotation	Quick menu	Increase parameter
	Main menu	Navigate downwards/clockwise

Counter- clockwise rotation	Quick menu	Decrease parameter
	Main menu	Navigate upwards/counterclockwise

Remote Control Activation

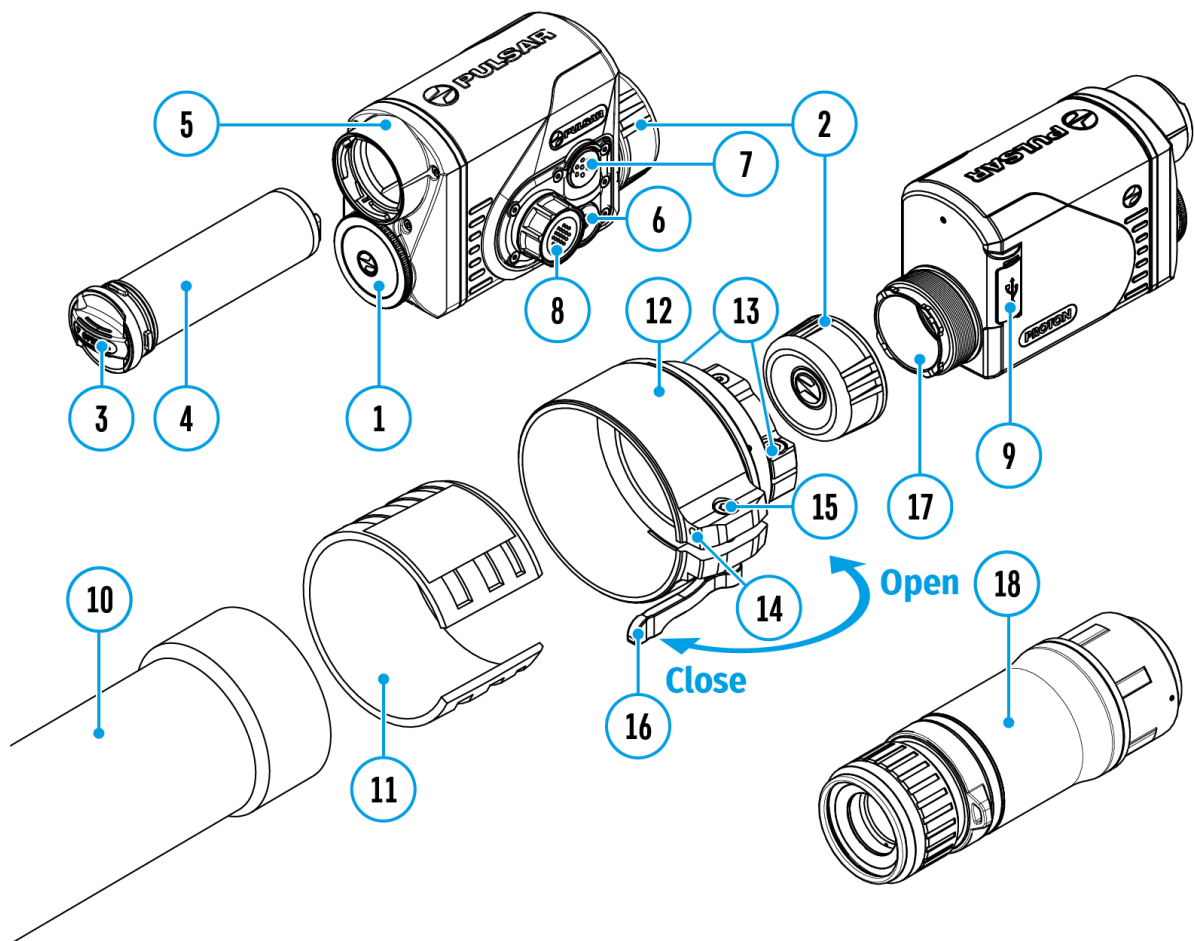
Show device diagram



1. Turn on the Bluetooth module (see the **Bluetooth** section).
2. In the **Bluetooth**  section of the menu, use the controller ring **(8)** to select the **Scan**  menu item.
3. Confirm your selection with a short press of the controller button **(8)** button.
4. Press and hold any button on the Remote Control. The Remote Control is visible in the Bluetooth network and can be connected during this time.

5. Use the controller ring **(8)** to select the remote control from the dropdown list that appears.
6. Confirm your selection with a short press of the controller button **(8)** button.

Notes:

- Once paired, the Remote Control can operate the Pulsar device.
- Going forward, the Remote Control will automatically connect to the paired device when within visible range.
- The name of the remote control and its battery charge level will appear in the list of paired devices at the bottom of the display in the **Bluetooth**  section of the menu.

Stream Vision

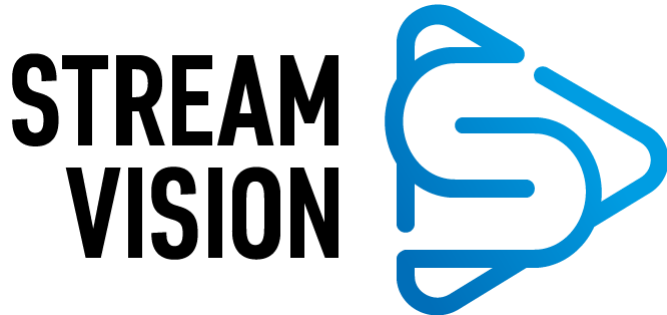

The **Proton XQ30** thermal imagers support Stream Vision technology, which enables the transmission of an image in real time from the attachment to your smartphone or tablet via Wi-Fi.

You can find further guidelines on Stream Vision [here](#).

[Download](#) from Google Play

[Download](#) from App Store

Find answers to frequently asked questions about using Stream Vision [here](#).

Firmware Update

Stream Vision

<https://www.youtube.com/embed/0Blu4rr-8IY>

1. Download free of charge Stream Vision App on [Google Play](#) or [App Store](#).
2. Connect your Pulsar device to your mobile device (smartphone or tablet).
3. Launch Stream Vision and go to section "My Devices".
4. Select your Pulsar device and press "Check Updates".
5. Wait for the update to download and install. Pulsar device will reboot and will be ready to operate.

Important:

- if your Pulsar device is connected to phone, please turn on mobile data transfer (GPRS/3G/4G) to download update;
- if your Pulsar device is not connected to your phone but it's already in the "My Devices" section, you may use Wi-Fi to download update.

Find answers to frequently asked questions about using Stream Vision [here](#).

Is your firmware up to date?

Click [here](#) to check the latest firmware for your device.

Stream Vision 2

1. Download free Stream Vision 2 App in [Google Play](#) or [App Store](#).
2. Connect your Pulsar device to your mobile device (smartphone or

tablet).

3. Launch Stream Vision 2 and go to section “Settings”.
4. Select your Pulsar device and press “Check firmware update”.
5. Wait for the update to download and install. Pulsar device will reboot and will be ready to operate.

Important:

- if your Pulsar device is connected to phone, please turn on mobile data transfer (GPRS/3G/4G) to download update;
- if your Pulsar device is not connected to your phone but is already listed in “Settings” > “My devices” section, you may use Wi-Fi to download update.

Find answers to frequently asked questions about using Stream Vision 2 [here](#).

USB Connection

Show device diagram

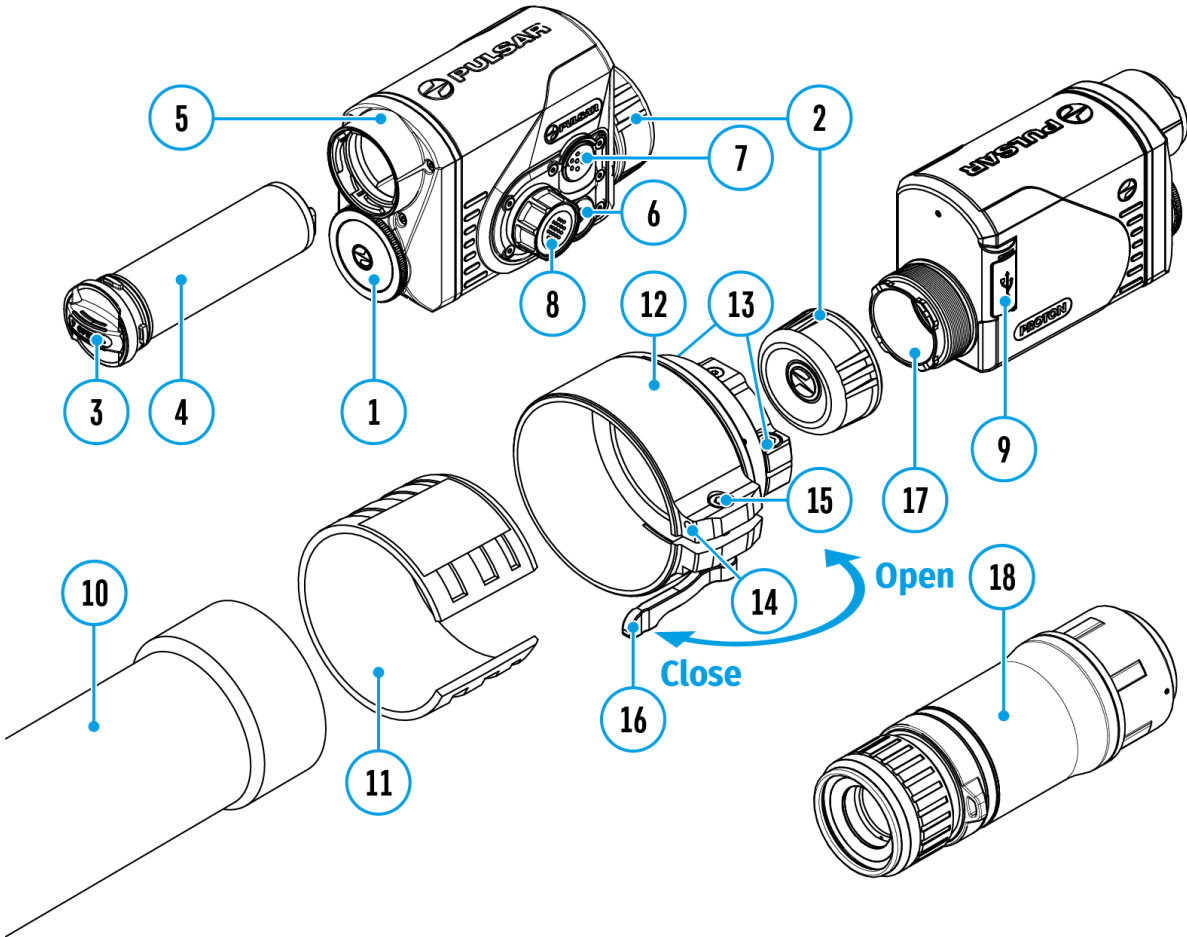

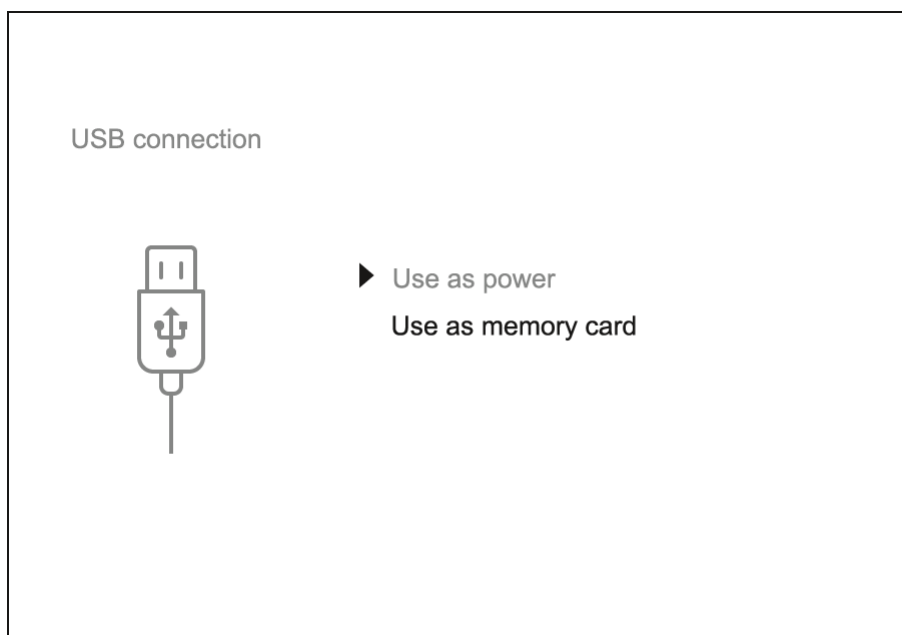

1. Connect one end of the USB cable to the device micro-USB port**(9)** and the other end to the port on your computer using a USB Type-A adapter.
2. Switch the device on with a short press of the **ON/OFF (6)** button (the computer will not detect the device if it is switched off).
3. The device is detected by the computer automatically and no drivers need to be installed.
4. Two connection modes will appear on the display: **Use as power** and **Use as memory card**.
5. Rotate the controller ring **(8)** to select the connection mode.
6. Press the controller button **(8)** briefly to confirm the selection.

Use as power

- When this mode is selected, the computer is used as an external power supply. The icon  appears in the status bar. The device will continue operating and all the functions are available.
- A battery installed in the device will not be charged.
- When disconnecting the USB from the device connected in **Use as power** mode, the device will continue to operate from the rechargeable battery if it is present and provided it has enough charge.

Use as memory card

- When this mode is selected, the device is recognized by the computer

as a flash card. This option is designed for working with files that are stored on the device's built-in memory. However, the device functions are not available in this mode and it will switch off automatically.

- If video recording was in progress when the connection was made, recording stops and the video is saved.
- When USB cable is disconnected from the device in **Use as memory card** mode, the device remains turned OFF. Press the **ON/OFF (6)** button to turn on the device.

Technical Inspection

It is recommended to carry out a technical inspection before each use of the device. Check the following:

- The device appearance (there should be no cracks on the body).
- The state of the objective and eyepiece lenses of the thermal imaging module (there should be no cracks, grease spots, dirt or other deposits).
- The state of the rechargeable battery (it should be charged) and the electric contacts (there should be no signs of salts or oxidation).
- The controls should be in working order.
- The thermal imaging module is properly and firmly fixed on the optical device.

Technical Maintenance and Storage

Maintenance should be carried out at least twice a year and include the following steps:

- Wipe the exterior metal and plastic surfaces with a cotton cloth to remove dust and dirt. To avoid damage to the paint coating, do not use chemically active substances, solvents, etc.
- Clean the electrical contacts of the rechargeable battery on the device using a non-greasy organic solvent.
- Check the eyepiece and the lens and if required remove dust and dirt from the optics (preferably using a non-contact method). Cleaning of the exterior surfaces of the optics should only be done with products specifically designed for this purpose.
- Always store the device in its carrying case in a dry, well-ventilated space. For prolonged storage, remove the batteries.

Troubleshooting

For technical support please contact support@pulsar-vision.com.

Answers to frequently asked questions about the devices can also be found in the [FAQ](#) section.

The device does not turn on

Possible cause

The battery is completely discharged.

Solution

Charge the battery.

The device does not operate from an external power source

Possible cause

The USB cable is damaged.

Solution

Replace the USB cable.

Possible cause

The external power supply is discharged.

Solution

Charge the external power supply (if necessary).

Blurred image with vertical stripes or an uneven background

Possible cause

Calibration is required.

Solution

Perform image calibration according to the [Microbolometer Calibration](#) section of the manual.

Poor quality image. There is noise or ghost images of previous scenes or objects

Possible cause

Manual calibration has been performed with the lens cover open.

Solution

Check the [Calibration Mode](#), close the lens cover and [calibrate](#) the device.

Black screen after calibration

Solution

If the image does not clear after calibration, you need to recalibrate.

Image is too dark

Possible cause

Brightness or contrast level is too low.

Solution

Adjust the brightness or contrast in the [Quick Menu](#).

Color bars appear on the display or the image disappears

Possible cause

The device was exposed to static charges during operation.

Solution

When the exposure to static charges is over, the device may either reboot automatically or require to be switched off and on again.

The image of the object being observed is missing

Possible cause

You are looking through glass.

Solution

Remove the glass or change the viewing position to avoid it.

Poor image quality / Reduced detection distance

Possible cause

These problems may occur during observation in adverse weather conditions (snow, rain, fog, etc.).

Smartphone or tablet cannot be connected to the device

Possible cause

Device password has been changed.

Solution

Delete the network and connect again using the password saved in the device.

Possible cause

The device is in an area with too many Wi-Fi networks that may be causing signal interference.

Solution

To ensure a stable Wi-Fi connection, relocate the device to an area with fewer or no Wi-Fi networks.

More information on solving problems with connection to Stream Vision by following the [link](#).

Missing or interrupted broadcasting via Wi-Fi

Possible cause

The smartphone or tablet is beyond reliable Wi-Fi range. There are obstacles between the device and the signal receiver (e.g. concrete walls).

Solution

Move the devices in line-of-sight and within range of the Wi-Fi signal.

More information on solving problems with connection to Stream Vision by following the [link](#).

When the device is used in low temperature conditions the image quality is worse than in positive temperatures.

Possible cause

In positive temperature conditions, objects being observed (surroundings and background) heat up differently because of thermal conductivity, thereby generating a high temperature contrast. Consequently, the image quality produced by the thermal imager will be better.

In low-temperature conditions, objects being observed (background) will cool down to roughly the same temperature, which leads to a greatly reduced temperature contrast and a degraded image quality. This is normal for all thermal imaging devices.

Remote control does not work

Possible cause

The Bluetooth module is not turned on.

Solution

Turn on the Bluetooth module according to the instructions (see the [Bluetooth](#) section).

Possible cause

The Remote control is not activated.

Solution

Activate the remote control according to instructions (see the [Remote Control Activation](#) section).

Possible cause

The Remote Control is out of range of the device.

Solution

Return to the device coverage area.

Possible cause

Remote control battery low.

Solution

Install a new CR2032 battery as follows: unscrew the screws on the rear cover of the Remote Control, remove the cover, install a new battery, and screw the cover with screws.

Legal Compliances and Disclaimers

Attention! A license is required for Thermal Imager Proton XQ30 when exporting outside your country.

Electromagnetic compatibility. This product complies with the requirements of European standard EN 55032: 2015, Class A.

Caution! Operation of this equipment in a residential environment could cause radio interference.

The manufacturer reserves the right at any time, without mandatory prior notice to the Customer, to make changes to the package contents (subject to the applicable laws, if any), design and characteristics that do not impair the quality of the Product.

Repair of the device is possible within 5 years.

